

Putty Unit

Operations Manual

This manual is applicable to the following models:

- IMP-CCP-MP
- IMP-CCP-MS
- IMP-CCP-MS-ATC
- IMP-CCP-BS
- ITW-CMB-APS-30-EXT
- ITW-CMB-APS-30-3-EXT
- ITW-CMB-APS-30-IM
- ITW-CMB-APS-30-3-IM
- ITW-CMB-PAT-30
- ITW-CMB-PAT-30-IM

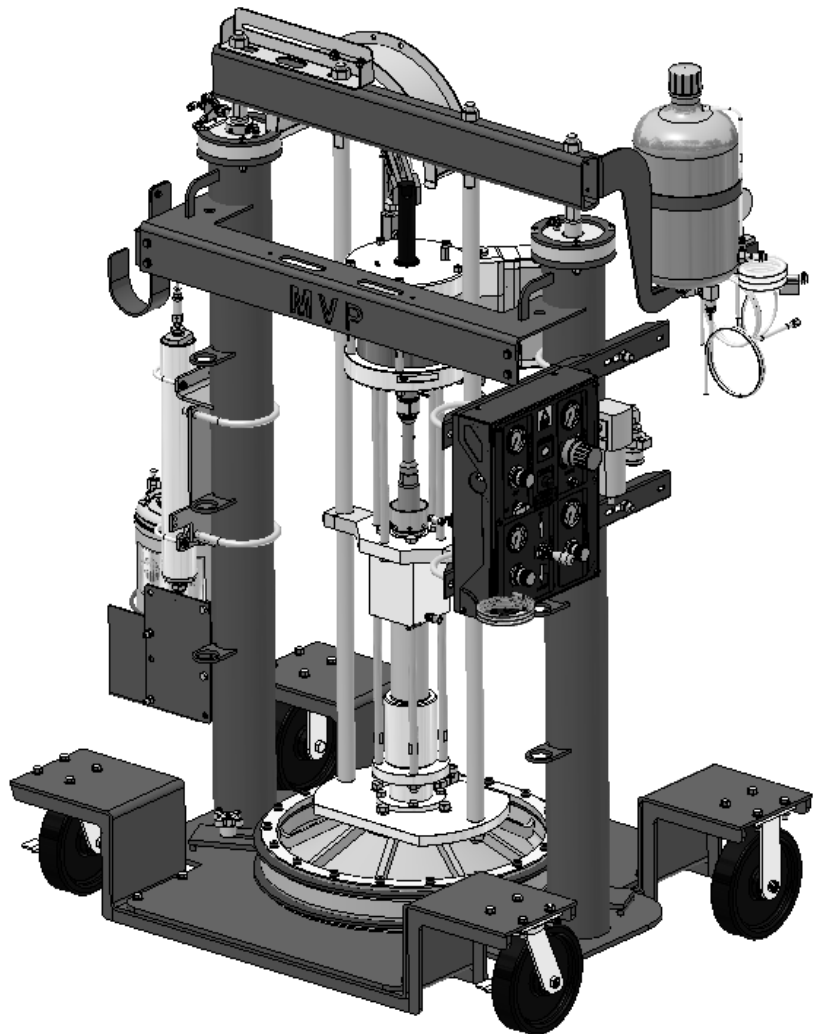

Rev. December 2019



Magnum Industries Europe Ltd. t/a Magnum Venus Products

Official Distributor of MVP Range in the United Kingdom and Ireland

Unit 22a, Navigation Drive, Hurst Business Park,
Brierley Hill, West Midlands, DY5 1UT, UK.

phone: +44 (0)1384 486222
email: info@mvpeurope.co.uk
website: www.mvpeurope.co.uk



Table of Contents

Section	Page
• Table of Contents	3
• Safety & Warning Information	4
• Introduction	15
• Assembling the Unit	18
• Getting Started	18
• Priming the Unit	19
• Mixing and Dispensing	21
• Testing and Adjusting	22
• Flushing and Shutting Down	24
• Changing an Empty Drum	25
• Performing Daily Tasks	26

Safety & Warning Information

Warnings

Due to the vast number of chemicals that could be used and their varying chemical reactions, the buyer and user of this equipment should determine all factors relating to the fluids used, including any of the potential hazards involved. Particular inquiry and investigation should be made into potential dangers relating to toxic fumes, fires, explosions, reaction times, and exposure of human beings to the individual components or their resultant mixtures. MVP assumes no responsibility for loss, damage, expense or claims for bodily injury or property damage, direct or consequential, arising from the use of such chemical components.

The end user is responsible for ensuring that the end product or system complies with all the relevant laws in the country where it is to be used and that all documentation is adhered to.

Recommended Occupational Safety & Health Act (OSHA) Documentation:

- 1910.94 Pertaining to ventilation
- 1910.106 Pertaining to flammable liquids
- 1910.107 Pertaining to spray finishing operations, particularly paragraph (m), Organic Peroxides and Dual Component Coatings

For Additional information, contact the Occupational Safety and Health Administration (OSHA) at <https://www.osha.gov/about.html>.

Recommended National Fire Protection Association (NFPA) Documentation:

- NFPA No.33 Chapter 14 Organic Peroxides and Dual Component Materials
- NFPA No. 63 Dust Explosion Prevention
- NFPA No. 70 National Electrical Code
- NFPA No. 77 Static Electricity
- NFPA No. 91 Blower and Exhaust System
- NFPA No. 654 Plastics Industry Dust Hazards

Fire Extinguisher – code ABC, rating number 4a60bc using Extinguishing Media –Foam, Carbon Dioxide, Dry Chemical, Water Fog, is recommended for this product and applications.

The following general warnings and guidelines are for the setup, use, grounding, maintenance, and repair of equipment. Additional product-specific warnings may be found throughout this manual as applicable. Please contact your nearest MVP Technical Service Representative if additional information is needed.

Safety Precautions

- Avoid skin contact and inhalation of all chemicals.
- Review Material Safety Data Sheet (MSDS) to promote the safe handling of chemicals in use.
- Restrict the use of all chemicals to designated areas with good ventilation.
- Chemicals are flammable and reactive.
- Noxious fumes released when combusted.
- Operate equipment in a ventilated environment only.
- Uncured liquid resins are highly flammable unless specifically labeled otherwise.
- Cured laminate, accumulations of overspray, and laminate sandings are highly combustible.
- Do not operate or move electrical equipment when flammable fumes are present.
- Ground all equipment.
- If a spark is seen or felt, immediately halt operation. Do not operate the equipment until the issue has been identified and repaired.
- Contaminated catalyst may cause fire or explosion.
- Containers may explode if exposed to fire / heat.
- Use and store chemicals away from heat, flames, and sparks.
- Do not smoke in work areas or near stored chemicals.
- Do not mix Methyl Ethyl Ketone Peroxide (MEKP) with materials other than polyethylene.
- Do not dilute MEKP.
- Keep food and drink away from work area.



CORROSIVE



FLAMMABLE



GROUNDING



EXPLOSIVE



DANGER



DANGER

Physical Hazards

- Never look directly into the spray gun fluid tip. Serious injury or death can result.
- Never aim the spray gun at or near another person. Serious injury or death can result.
- Chemical compounds can be severely irritating to the eyes and skin.
- Inhalation, ingestion, or injection may damage internal organs and lead to pulmonary disorders, cancers, lymphomas, and other diseases or health conditions.
- Other potential health effects include: irritation of the eyes and upper respiratory tract, headache, light-headedness, dizziness, confusion, drowsiness, nausea, vomiting, and occasionally abdominal pain.
- Eye contact: Immediately flush with water for at least 15 minutes and seek immediate medical attention.
- Skin Contact: Immediately wash with soap and water and seek immediate medical attention.
- Inhalation: Move the person to fresh air and seek immediate medical attention.
- Do not remove shields, covers, or safety features on equipment that is in use.
- Never place fingers, hands, or any body part near or directly in front of the spray gun fluid tip. The force of the liquid as it exits the spray tip can shoot liquid through the skin.
- Keep hands and body parts away from any moving equipment or components.
- Do not stand under plunger
- An improperly loaded drum may lead to an imbalance, causing a unit to tip over

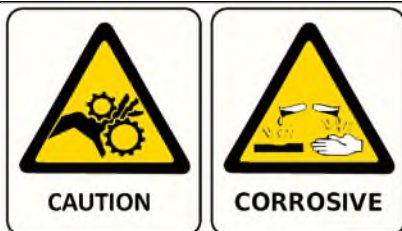

Personal Protective Equipment (PPE)

- MVP recommends the use of personal safety equipment with all products in our catalog.
- Wear safety goggles, hearing protection, a respirator, and chemical resistant gloves.
- Wear long sleeve shirts or jackets and pants to minimize skin exposure.
- PPE should be worn by operators and service technicians to reduce the risk of injury.



For Additional information, contact the Occupational Safety and Health Administration (OSHA). <https://www.osha.gov/about.html>

Symbol Definitions



Indicates the risk of contact with chemicals that are hazardous, which may lead to injury or death.



Indicates the risk of contact with voltage / amperage that may lead to serious injury or death



Indicates that the materials being used are susceptible to combustion



Indicates the risk of contact with moving components that may lead to serious injury or death.



Indicates that the system or component should be grounded before proceeding with use or repair.



Indicates the use of lit cigarettes or cigars is prohibited, because the materials being used are susceptible to combustion.



Indicates that the materials and/or the process being performed can lead to ignition and explosion.



A recommendation for the use of Personal Protective Equipment (PPE) before using or repairing the product.

Polymer Matrix Materials: Advanced Composites

Potential health hazards associated with the use of advanced composites can be controlled through the implementation of an effective industrial hygiene and safety program.

https://www.osha.gov/dts/osta/otm/otm_iii/otm_iii_1.html#t_iii:1_1

Resins		
Composite Component	Organ System Target (Possible Target)	Known (Possible) Health Effect
Epoxy resins	Skin, lungs, eyes	Contact and allergic dermatitis, conjunctivitis
Polyurethane resins	Lungs, skin, eyes	Respiratory sensitization, contact dermatitis, conjunctivitis
Phenol formaldehyde	Skin, lungs, eyes	As above (potential carcinogen)
Bismaleimides (BMI)	Skin, lungs, eyes	As above (potential carcinogen)
Polyamides	Skin, lungs, eyes	As above (potential carcinogen)
Reinforcing materials		
Composite Component	Organ System Target (Possible Target)	Known (Possible) Health Effect
Aramid fibers	Skin (lungs)	Skin and respiratory irritation, contact dermatitis (chronic interstitial lung disease)
Carbon/graphite fibers	Skin (lungs)	As noted for aramid fibers
Glass fibers (continuous filament)	Skin (lungs)	As noted for aramid fibers
Hardeners and curing agents		
Composite Component	Organ System Target (Possible Target)	Known (Possible) Health Effect
Diaminodiphenylsulfone	N/A	No known effects with workplace exposure
Methylenedianiline	Liver, skin	Hepatotoxicity, suspect human carcinogen
Other aromatic amines		
Composite Component	Organ System Target (Possible Target)	Known (Possible) Health Effect
Meta-phenylenediamine (MPDA)	Liver, skin (kidney, bladder)	Hepatitis, contact dermatitis (kidney and bladder cancer)
Aliphatic and cyclo-aliphatic amines	Eyes, skin	Severe irritation, contact dermatitis
Polyaminoamide	Eyes, skin	Irritation (sensitization)
Anhydride	Eyes, lungs, skin	Severe eye and skin irritation, respiratory sensitization, contact dermatitis

Catalyst - Methyl Ethyl Ketone Peroxide (MEKP)

MEKP is among the more hazardous materials found in commercial channels. The safe handling of the “unstable (reactive)” chemicals presents a definite challenge to the plastics industry. The highly reactive property which makes MEKP valuable to the plastics industry in producing the curing reaction of polyester resins also produces the hazards which require great care and caution in its storage, transportation, handling, processing and disposal. MEKP is a single chemical. Various polymeric forms may exist which are more or less hazardous with respect to each other. These differences may arise not only from different molecular structures (all are, nevertheless, called “MEKP”) and from possible trace impurities left from the manufacture of the chemicals, but may also arise by contamination of MEKP with other materials in its storage or use. Even a small amount of contamination with acetone, for instance, may produce an extremely shock-sensitive and explosive compound.



WARNING

Contamination with promoters, materials containing promoters (such as laminate sandings), or with any readily oxidizing material (such as brass or iron) will cause exothermic redox reactions which can be explosive in nature. Heat applied to MEKP or heat buildup from contamination reactions can cause the material to reach its Self-Accelerating Decomposition Temperature (SADT).

Researchers have reported measuring pressure rates-of-rise well over 100,000 psi per second when certain MEKP's reach their SADT. For comparison, the highest-pressure rate-of-rise listed in NFPA Bulletin NO.68, “Explosion Venting”, is 12,000 psi per second for an explosion of 12% acetylene and air. The maximum value listed for a hydrogen explosion is 10,000 psi per second. Some forms of MEKP, if allowed to reach their SADT, will burst even an open topped container. This suggests that it is not possible to design a relief valve to vent this order of magnitude of pressure rate-of-rise. The user should be aware that any closed container, be it a pressure vessel, surge chamber, or pressure accumulator, could explode under certain conditions. There is no engineering substitute for care by the user in handling organic peroxide catalysts. If, at any time, the pressure relieve valve on top of the catalyst tank should vent, the area should be evacuated at once and the fire department called. The venting could be the first indication of a heat, and therefore, pressure build-up that could eventually lead to an explosion. Moreover, if a catalyst tank is sufficiently full when the pressure relief valve vents, some catalyst may spray out, which could cause eye injury. For this reason, and many others, anyone whose job puts them in an area where this vented spray might go, should always wear full eye protection even when laminating operations are not taking place.

Safety in handling MEKP depends to a great extent on employee education, proper safety instructions, and safe use of the chemicals and equipment. Workers should be thoroughly informed of the hazards that may result from improper handling of MEKP, especially regarding contamination, heat, friction and impact. They should be thoroughly instructed regarding the proper action to be taken in the storage, use, and disposal of MEKP and other hazardous materials used in the laminating operation. In addition, users should make every effort to:

- Store MEKP in a cool, dry place in original containers away from direct sunlight and away from other chemicals.
- Keep MEKP away from heat, sparks, and open flames.
- Prevent contamination or MEKP with other materials, including polyester over spray and sandings, polymerization accelerators and promoters, brass, aluminum, and non-stainless steels.

- Never add MEKP to anything that is hot, since explosive decomposition may result.
- Avoid contact with skin, eyes, and clothing. Protective equipment should be worn at all times. During clean-up of spilled MEKP, personal safety equipment, gloves, and eye protection must be worn. Firefighting equipment should be at hand and ready.
- Avoid spillage, which can heat up to the point of self-ignition.
- Repair any leaks discovered in the catalyst system immediately, and clean-up the leaked catalyst at once in accordance with the catalyst manufacturer's instructions.
- Use only original equipment or equivalent parts from Magnum Venus Products in the catalyst system (i.e.: hoses, fitting, etc.) because a dangerous chemical reaction may result between substituted parts and MEKP.
- Catalyst accumulated from the purging of hoses or the measurement of fluid output deliveries should never be returned to the supply tank, such catalyst should be diluted with copious quantities of clean water and disposed of in accordance with the catalyst manufacturer's instructions.

The extent to which the user is successful in accomplishing these ends and any additional recommendations by the catalyst manufacturer determines largely the safety that will be present in his operation.

Clean-Up Solvents and Resin Diluents



WARNING

A hazardous situation may be present in your pressurized fluid system! Hydro carbon solvents can cause an explosion when used with aluminum or galvanized components in a closed (pressurized) fluid system (pump, heaters, filters, valves, spray guns, tanks, etc.). An explosion could cause serious injury, death, and/or substantial property damage. Cleaning agents, coatings, paints, etc. may contain Halogenated Hydrocarbon solvents. Some Magnum Venus Products spray equipment includes aluminum or galvanized components and will be affected by Halogenated Hydrocarbon solvents.

There are three key elements to the Halogenated Hydrocarbon (HHC) solvent hazard.

- | | | |
|----|---|--|
| 1. | The presence of HHC solvents. | 1,1,1 – Trichloroethane and Methylene Chloride are the most common of these solvents. However, other HHC solvents are suspect if used; either as part of paint or adhesives formulation, or for clean-up flushing. |
| 2. | Aluminum or Galvanized Parts. | Most handling equipment contains these elements. In contact with these metals, HHC solvents could generate a corrosive reaction of a catalytic nature. |
| 3. | Equipment capable of withstanding pressure. | When HHC solvent contact aluminum or galvanized parts inside a closed container such as a pump, spray gun, or fluid handling system, the chemical reaction can, over time, result in a build-up of heat and pressure, which can reach explosive proportions. When all three elements are present, the result can be an extremely violent explosion. The reaction can be sustained with very little aluminum or galvanized metal; any amount of aluminum is too much. |

- The reaction is unpredictable. Prior use of an HHC solvent without incident (corrosion or explosion) does NOT mean that such use is safe. These solvents can be dangerous alone (as a clean-up or flushing agent) or when used as a component or a coating material. There is no known inhibitor that is effective under all circumstances. Mixing HHC solvents with other materials or solvents such as MEKP, alcohol, or toluene may render the inhibitors ineffective.
- The use of reclaimed solvents is particularly hazardous. Reclaimers may not add any inhibitors. The possible presence of water in reclaimed solvents could also feed the reaction.
- Anodized or other oxide coatings cannot be relied upon to prevent the explosive reaction. Such coatings can be worn, cracked, scratched, or too thin to prevent contact. There is no known way to make oxide coatings or to employ aluminum alloys to safely prevent the chemical reaction under all circumstances.
- Several solvent suppliers have recently begun promoting HHC solvents for use in coating systems. The increasing use of HHC solvents is increasing the risk. Because of their exemption from many state implementation plans as Volatile Organic Compounds (VOCs), their low flammability hazard, and their not being classified as toxic or carcinogenic substances, HHC solvents are very desirable in many respects.

**WARNING**

Do not use Halogenated Hydrocarbon (HHC) solvents in pressurized fluid systems having aluminum or galvanized wetted parts.

Magnum Venus Products is aware of NO stabilizers available to prevent HHC solvents from reaction under all conditions with aluminum components in closed fluid systems. HHC solvents are dangerous when used with aluminum components in a closed fluid system.

- Consult your material supplier to determine whether your solvent or coating contains Halogenated Hydrocarbon solvents.
- Magnum Venus Products recommends that you contact your solvent supplier regarding the best non-flammable clean-up solvent with the heat toxicity for your application.
- If, however, you find it necessary to use flammable solvents, they must be kept in approved, electrically grounded containers.
- Bulk solvent should be stored in a well-ventilated, separate building, 50 feet away from your main plant.
- You should only allow enough solvent for one day's use in your laminating area.
- NO SMOKING signs must be posted and observed in all areas of storage or where solvents and other flammable materials are used.
- Adequate ventilation (as covered in OSHA Section 1910.94 and NFPA No.91) is important wherever solvents are stored or used, to minimize, confine and exhaust the solvent vapors.
- Solvents should be handled in accordance with OSHA Section 1910.106 and 1910.107.

Catalyst Diluents

Magnum Venus Products spray-up and gel-coat systems currently produced are designed so that catalyst diluents are not required. Magnum Venus Products therefore recommends that diluents not be used to avoid possible contamination which could lead to an explosion due to the handling and mixing of MEKP and diluents. In addition, it eliminates any problems from the diluent being contaminated through rust particles in drums, poor quality control on the part of the diluents suppliers, or any other reason. If diluents are absolutely required, contact your catalyst supplier and follow his instructions explicitly. Preferably the supplier should premix the catalyst to prevent possible “on the job” contamination while mixing.



WARNING

If diluents are not used, remember that catalyst spillage and gun, hose, and packing leaks are potentially more hazardous since each drop contains a higher concentration of catalyst and will therefore react more quickly with overspray and the leak.

Cured Laminate, Overspray and Laminate Sandings Accumulation

- Remove all accumulations of overspray, Fiberglass Reinforced Plastic (FRP) sandings, etc. from the building as they occur. If this waste is allowed to build up, spillage of catalyst is more likely to start a fire; in addition, the fire would burn hotter and longer.
- Floor coverings, if used, should be non-combustible.
- Spilled or leaked catalyst may cause a fire if it comes in contact with an FRP product, oversprayed chop or resin, FRP sandings or any other material with MEKP.

To prevent spillage and leakage, you should:

- | | |
|--|---|
| 1. Maintain your Magnum Venus Products System. | Check the gun several times daily for catalyst and resin packing or valve leaks. REPAIR ALL LEAKS IMMEDIATELY. |
| 2. Never leave the gun hanging over or lying inside the mold. | A catalyst leak in this situation would certainly damage the part, possibly the mold, and may cause a fire. |
| 3. Inspect resin and catalyst hoses daily for wear or stress at the entry and exits of the boom sections and at the hose and fittings. | Replace if wear or weakness is evident or suspected. |
| 4. Arrange the hoses and fiberglass roving guides so that the fiberglass strands DO NOT rub against any of the hoses at any point. | If allowed to rub, the hose will be cut through, causing a hazardous leakage of material which could increase the danger of fire. Also, the material may spew onto personnel in the area. |

Toxicity of Chemicals

- Magnum Venus Products recommends that you consult OSHA Sections 1910.94, 1910.106, 1910.107 and NFPA No.33, Chapter 14, and NFPA No.91.
- Contact your chemical supplier(s) and determine the toxicity of the various chemicals used as well as the best methods to prevent injury, irritation and danger to personnel.
- Also determine the best methods of first aid treatment for each chemical used in your plant.

Equipment Safety

Magnum Venus Products suggest that personal safety equipment such as EYE GOGGLES, GLOVES, EAR PROTECTION, and RESPIRATORS be worn when servicing or operating this equipment. Ear protection should be worn when operating a fiberglass chopper to protect against hearing loss since noise levels can be as high as 116 dB (decibels). This equipment should only be operated or serviced by technically trained personnel!



CAUTION

Never place fingers, hands, or any body part near or directly in front of the spray gun fluid tip. The force of the liquid as it exits the spray tip can cause serious injury by shooting liquid through the skin. NEVER LOOK DIRECTLY INTO THE GUN SPRAY TIP OR POINT THE GUN AT OR NEAR ANOTHER PERSON.



DANGER

Contaminated catalyst may cause fire or explosion. Before working on the catalyst pump or catalyst accumulator, wash hands and tools thoroughly. Be sure work area is free from dirt, grease, or resin. Clean catalyst system components with clean water daily.



DANGER

Eye, skin, and respiration hazard. The catalyst MEKP may cause blindness, skin irritation, or breathing difficulty. Keep hands away from face. Keep food and drink away from work area.

Treatment of Chemical Injuries



CAUTION

Refer to your catalyst manufacturer's safety information regarding the safe handling and storage of catalyst. Wear appropriate safety equipment as recommended.

Great care should be used in handling the chemicals (resins, catalyst and solvents) used in polyester systems. Such chemicals should be treated as if they hurt your skin and eyes and as if they are poison to your body. For this reason, Magnum Venus Products recommends the use of protective clothing and eye wear in using polyester systems. However, users should be prepared in the event of such an injury.

Precautions include:

1. Know precisely what chemicals you are using and obtain information from your chemical supplier on what to do in the event the chemical gets onto your skin or into the eyes, or if swallowed.
2. Keep this information together and easily available so that it may be used by those administering first aid or treating the injured person.
3. Be sure the information from your chemical supplier includes instructions on how to treat any toxic effects the chemicals have.

**WARNING**

Contact your doctor immediately in the event of an injury. If the product's MSDS includes first aid instructions, administer first aid immediately after contacting a doctor.

Fast treatment of the outer skin and eyes that contact chemicals generally includes immediate and thorough washing of the exposed skin and immediate and continuous flushing of the eyes with lots of clean water for at least 15 minutes or more. These general instructions of first aid treatment may be incorrect for some chemicals; you must know the chemicals and treatment before an accident occurs. Treatment for swallowing a chemical frequently depends upon the nature of the chemical.

Emergency Stop Procedure

In an emergency, follow these steps to stop a UPS System:

1. The ball valve located where the air enters the power head of the resin pump, should be moved to the "OFF" or closed position.

Note ***The "open" or "on" position is when the ball valve handle is parallel (in line) with the ball valve body. The "closed" or "off" position is when the ball valve handle is perpendicular (across) the ball valve body.***

2. Turn all system regulators to the "OFF" position (counter-clockwise) position.
3. Verify / secure the catalyst relief line, located on the catalyst relief valve.
4. Verify / secure the resin return line, located on the resin filter.
5. Place a container under the resin pump ball valve to catch ejected resin.
6. Locate the ball valve on the resin pump.
7. Rotate the ball valve 90 degrees to the "On" or open position.

Grounding

Grounding an object means providing an adequate path for the flow of the electrical charge from the object to the ground. An adequate path is one that permits charge to flow from the object fast enough that it will not accumulate to the extent that a spark can be formed. It is not possible to define exactly what will be an adequate path under all conditions since it depends on many variables. In any event, the grounding means should have the lowest possible electrical resistance.

Grounding straps should be installed on all loose conductive objects in the spraying area. This includes material containers and equipment. Magnum Venus Products recommends grounding straps be made of AWG No.18 stranded wire as a minimum and the larger wire be used where possible. NFPA Bulletin No77 states that the electrical resistance of such a leakage path may be as low as 1 meg ohm (10 ohms) but that resistance as high as 10,000 meg ohms will produce an adequate leakage path in some cases.



CAUTION

Whenever flammable or combustible liquids are transferred from one container to another, or from one container to the equipment, both containers or container and equipment shall be effectively bonded and grounded to dissipate static electricity. For further information, see National Fire Protection Association (NFPA) 77, titled “Recommended Practice on Static Electrical”. Refer especially to section 7-7 titled “Spray Application of Flammable and Combustible Materials”.

Introduction

This manual provides information for the operation, maintenance, and simple repair of the MVP Putty Unit. The following procedures are included:

- Step-by-step assembly and disassembly
- Installation, start-up, and shut-down instructions
- Step-by-step operation instructions



Please read this manual carefully and retain for future reference. Follow the steps in the order given, otherwise you may damage the equipment or injure yourself.

Component Assemblies

MVP's Putty Unit consists of multiple components. Each component has its own detailed manual and drawings. For complete repair and maintenance instructions, refer to the appropriate manuals.

- HV PRO GUN REPAIR MANUAL – POUR UNIT
- OR
- CLASSIC PRO GUN REPAIR MANUAL – SPRAY UNIT

- POWERSLIDE POWERHEAD MANUAL – DUAL ROD – 5000 & 7000 SERIES
- CPPLS-1000 CHOP CHECK FLUID SECTION MANUAL
- VHPC-1000 METERING PUMP MANUAL – PHPC-7200

Air Requirements

8. The system requires a supply of air (30 cfm) and at least 100 psi (7 bar).

- 9. The unit requires a 1/2 inch (12 - 13 mm) inside diameter air hose minimum (use caution when using quick disconnects; they may restrict air flow).
- 10. Preferably the air will be clean, dry, and oil free.

Unit Overview

Below helps identify the main components and controls the operator needs to know for proper operation for the unit.

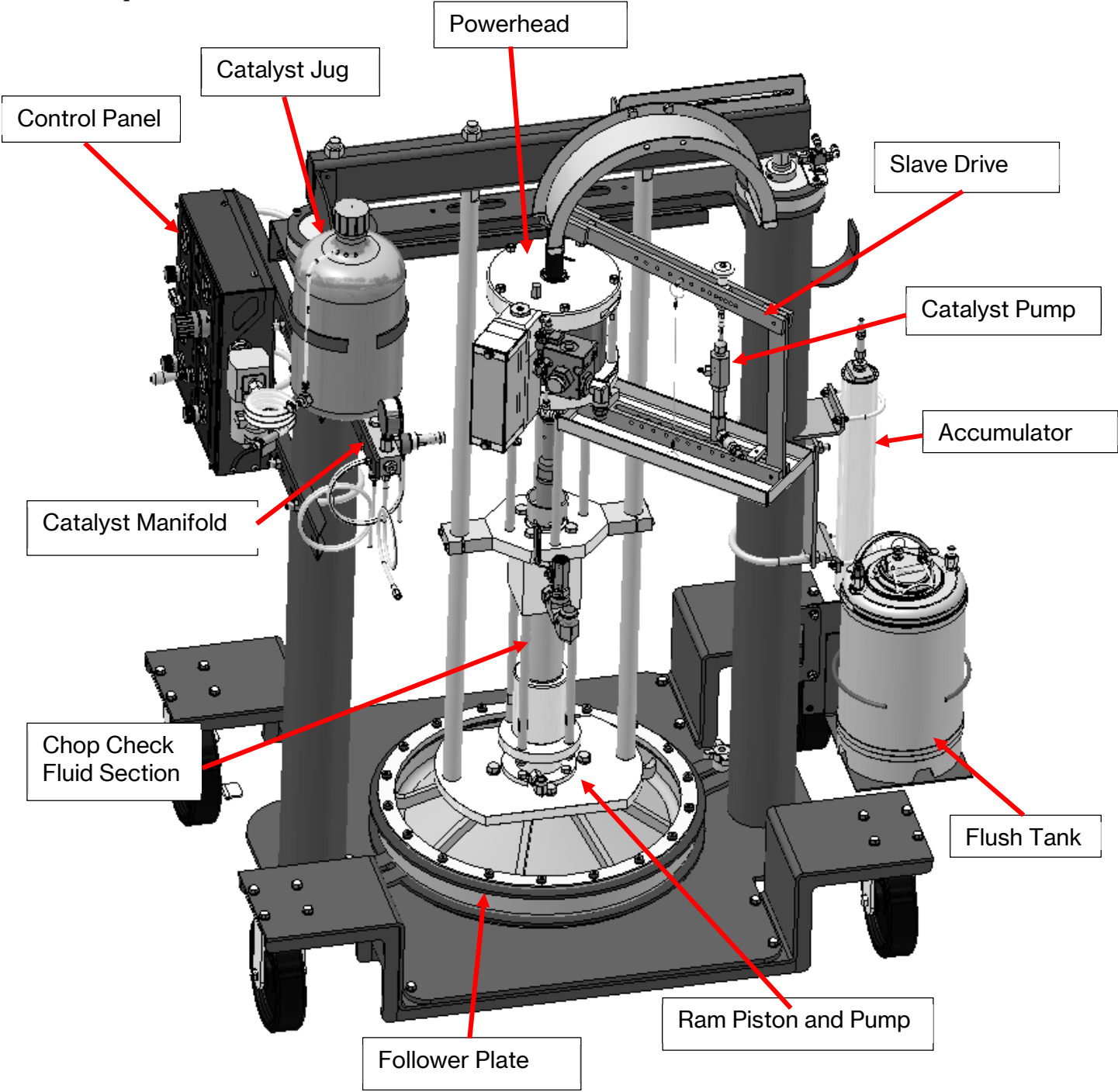

Overview of Controls

Following is a brief description of the main controls and their function. Some controls may be blanked out depending on the unit's configuration.

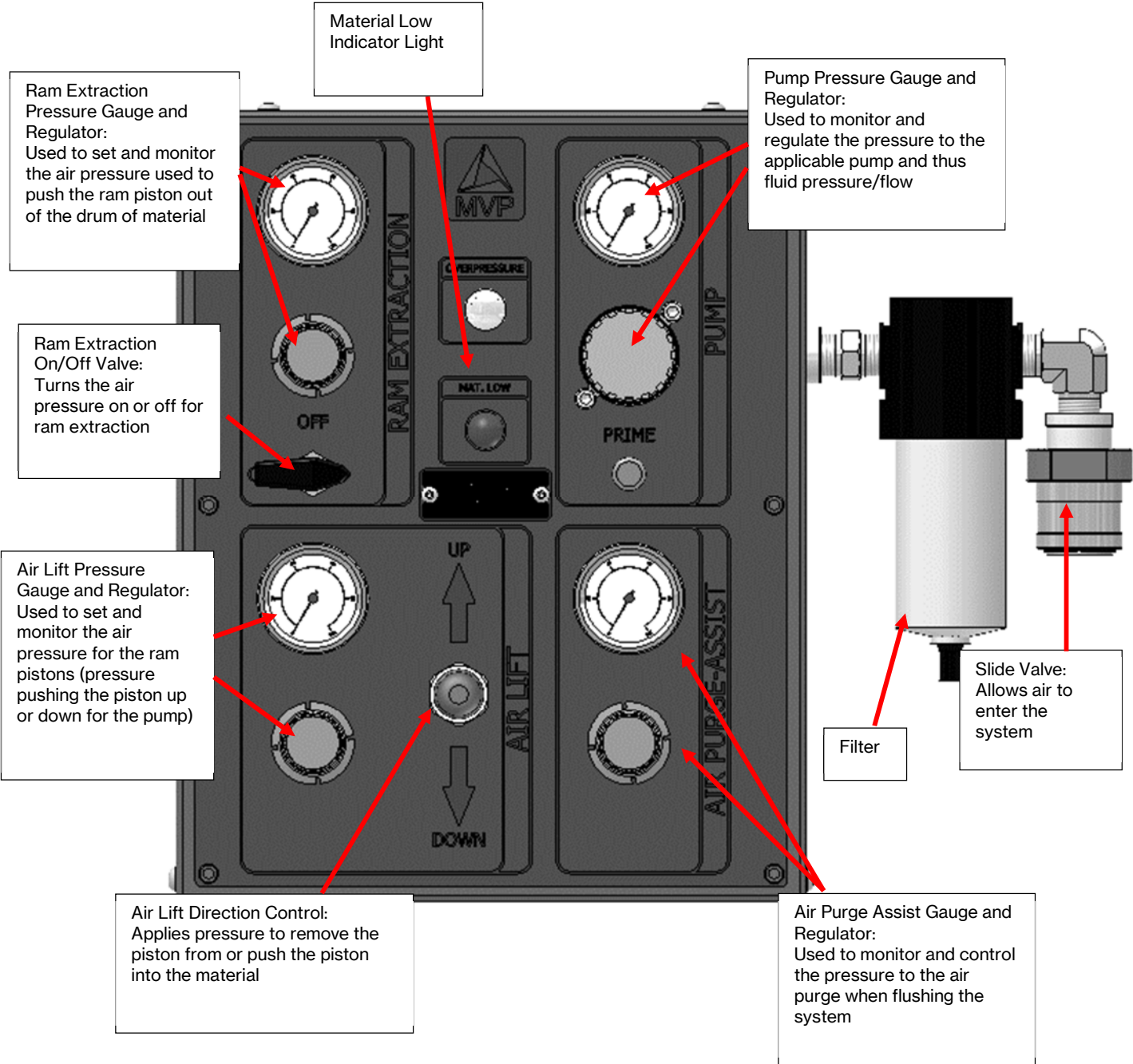

Assembling the Unit

11. Swing up and attach the catalyst manifold and bracket to the support bar.
12. Connect the catalyst hose from the catalyst pump outlet to the catalyst manifold.
13. Install the catalyst jug into the catalyst jug bracket.
14. Connect the poly tube from the catalyst relief valve to the top edge of the catalyst jug.
15. Connect the poly tube from the catalyst dump valve to the top edge of the catalyst jug.
16. Measure and cut the catalyst feed tube and then install onto the catalyst pump inlet fitting.
17. Attach the flush tank bracket to the main post and install the flush tank.

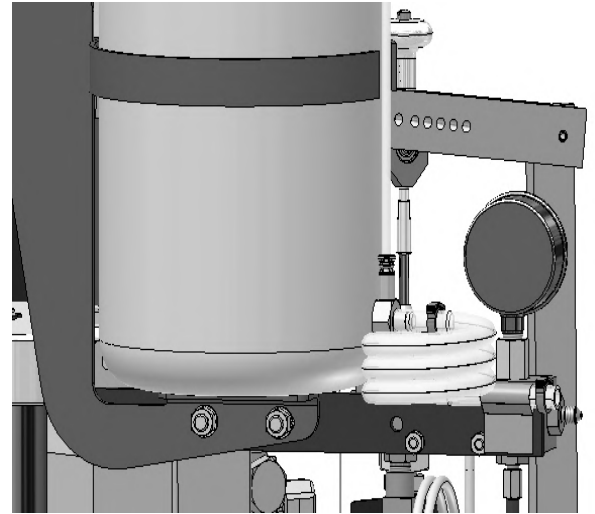

Figure 1. Catalyst Jug Bracket & Manifold

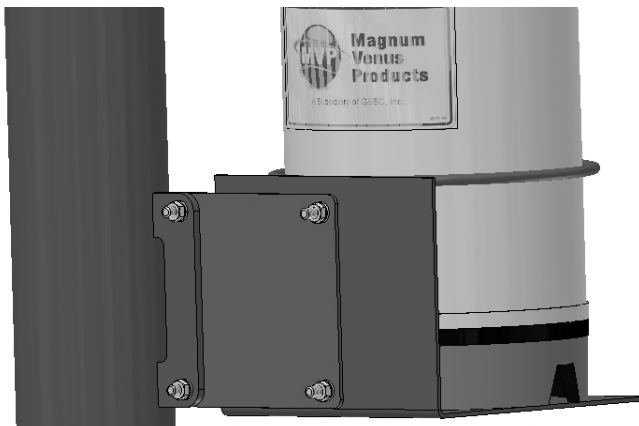
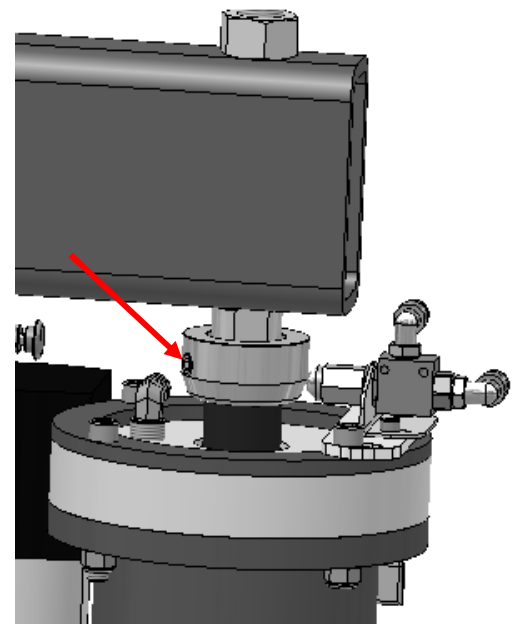

Figure 2. Flush Tank Attachment

18. Attach the flush tube (solvent to gun) to the outlet side of the flush tank.
19. Attach ¼ inch air hose to the flush tank or flush pump.

Getting Started

20. Check all hoses for wear or damage; replace as necessary.
21. Check to make sure you have appropriate quantities of material to complete the job.
22. Check and repair or replace any damaged items before beginning operations.
23. On the putty ram unit, check the ram low level limit.
24. If low limit requires adjustment, loosen the bolt holding the shaft collar in place, slide to the desired position on the post and re-tighten.



Priming the Unit

Prime Solvent

25. Close the main air supply slide valve on the side of the control panel.
26. Connect ½ inch air supply to the inlet port of the slide valve.
27. Turn all regulators counterclockwise to full off and close all ball valves on the pump supply.
28. Make sure ram control lever is in the center (neutral) position.
29. Open the main air supply slide valve and listen for air leaks.
30. Secure all fittings and correct any leaks, if found.
31. Fill the flush tank with appropriate cleaning agent or place solvent pump into an approved container full of cleaning agent.
32. Close the relief valve on top of the flush tank.
33. Open the ball valve and slowly turn up regulator pressure to the flush tank or solvent pump.

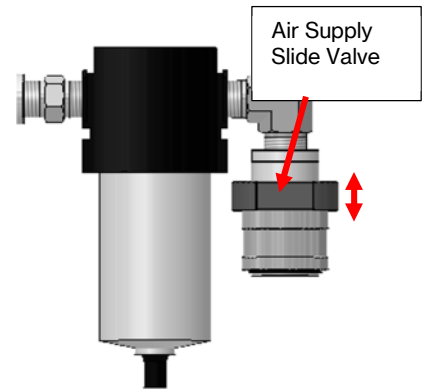

Note ***If pump is used, turn up the regulator until the pump begins stroking.***

34. Secure solvent leaks, if any.
35. Bring solvent pump pressure up to between 35 and 40 psi (2.2 – 2.8 bar) or regulator gauge or 50 psi (3.5 bar) for flush tank gauge.
36. Wait for solvent pump to stall or stop.
37. Test the flush system by pressing the flush buttons on the gun block for both solvent and air purge if applicable.

Prime Putty Pump

38. Fill packing nut solvent cup with throat seal liquid (TSL).
39. Open the ball valve off the air lift cylinder regulator.
40. Turn the ram direction control lever to the up position.
41. Slowly turn up the air lift ram pressure regulator to between 10 and 20 psi (0.7 to 1.4 bar).
42. As ram begins to lift, check for hoses kinking or catching and correct as necessary.
43. Allow ram to go up to the fully raised position to allow clearance for the material container.
44. Stop the ram in the fully raised position and tape the round piece of plastic known as the piston boot to the barrel piston, making sure the hole in the center is centered with the opening at the bottom of the barrel piston.

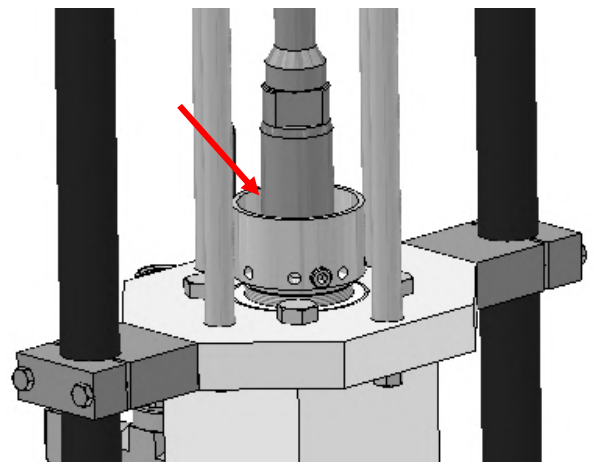

Note ***If the drum of material you are using has a plastic liner, use the ring from the drum top to hold the liner in place or tape the liner to the outside of the drum to prevent it from being pushed down into the drum.***

45. Inspect the material container for dents or damage.

Note ***Using a dented or damaged container can damage the piston seals and cause leaking.***

46. Slide the material container onto the unit and center to the barrel piston.

47. Double check to make sure the opening of the plastic piston boot is lined up with the intake of the pump.

48. Open the ball valve located at the top of the barrel piston to allow air trapped between the piston and putty to escape.

49. Turn the direction control handle to the down position to lower the piston into the container.

50. Once piston has started into the container, slowly increase the air lift regulator pressure to between 40 and 60 psi (2.7 and 4 bar).

51. Allow time for air to be pushed out of the ball valve at the top of the barrel piston.

52. Once the piston has come to a complete stop and a small amount of material starts to come out of the ball valve, close the valve.

53. Remove the mixer assembly or nozzle from the front of the gun mix chamber.

54. Position the dispensing block/gun over an appropriate waste container.

55. Prime the gun as follows:

- *If you have a pour gun:* Pull the manual gun handle back to the open position so the 3-way valve is engaged.
- *If you have a spray gun:* Pull the trigger all the way back and engage the trigger lock. The mix chamber should not be attached.

56. Open the pump ball valve to allow pump operation.

57. At the air manifold, slowly increase the pump pressure regulator.

58. Adjust pump regulator as needed to maintain a slow and uniform movement of the putty pump.

59. Allow the pump to run until a steady flow of material is being dispensed out of the dispensing block with no air pockets.

60. Close the gun.

61. Flush the dispensing head.

62. Leave the ram control lever in the down position.

Prime Catalyst

63. Do not use the quick pin to attach the upper catalyst pump bearing block to the slave arm at this time.

64. Check to make sure all catalyst hoses and fittings are tight.

65. Remove the mix chamber from the front of the gun.

66. Fill the catalyst jug $\frac{3}{4}$ full with appropriate catalyst.
67. Close the catalyst recirculation valve on the catalyst manifold.
68. Prime catalyst to the gun as follows:
 - *If you have a pour gun:* Pull the manual gun handle all the way back. The gun handle should engage the button on the 3-way valve.
 - *If you have a spray gun:* Pull the trigger all the way back and engage the trigger lock. The mix chamber should not be attached at this time.
69. Use the priming knob at the top of the catalyst pump to slowly hand prime using long up and down strokes until a steady flow of catalyst is being dispensed out of the gun.
70. Lean the top of the catalyst pump against the connecting rod.

Note ***When hand-priming catalyst pump, resistance should increase uniformly between the up stroke and the down stroke when building pressure.***

71. Secure leaks, if any.
72. Close the dispensing head/gun.
73. Position outlet of head/gun over a flush container.
74. Flush and air purge as necessary.



CAUTION

A sudden purge of material from the dispensing head is likely and could splash.

Mixing and Dispensing

75. Apply lubricant to the threads of the static mixer assembly and attach it to the outlet on the dispensing head/gun.
76. Push the priming button on the air manifold to build fluid pressure.
77. While pushing the priming button, slowly increase the putty pump regulator to between 30 and 40 psi (2 to 2.8 bar) as a starting point.
78. Once pump comes to a stop, release the priming button.
79. With the dispense head/gun closed and the catalyst pressure dump valve closed, hand prime catalyst pressure to at least 200 psi (14 bar).
80. Pin the top and bottom of the catalyst pump at the desired percentage.
81. Install the catalyst injector and mix chamber onto the gun.
82. Use a small amount of red grease on the mix housing threads and install the mixer as follows:
 - *If you have a pour gun:* Install the mixing tube onto the gun head, making sure there is a seal between the mix housing and the adapter union fitting. The static mixers have a notch on one end that inner lock the four mixers together that should face up when installing into the mix tube.

- *If you have a spray gun:* Install the mixer housing and nozzle assembly onto the mix chamber. Attach an air supply to the splatter nozzle.
83. Open the dispensing head/gun and allow mixed material to flow out of mixer into a container for 4 – 5 seconds.
 84. Begin dispensing a bead of material and check for mix by reviewing uniformity of color.

Testing and Adjusting

Output and Cure Time Test

85. Weigh and zero out a container on an appropriately sized scale.
86. Open the dispense head/gun and allow material to flow for a second or two, then quickly move over the container.
87. Start timing for 1 minute, then close the dispense head/gun.
88. Weigh the dispensed material to determine the weight per minute.
89. Observe the material until it begins to gel and note the elapsed time.

Mix Meter / Pour Test

90. Lay out a test strip of material such as cardboard, fabric, or plastic.
91. Pull the gun trigger and begin pouring a bead of material along the test strip in a zig-zag pattern, reversing direction when you hear the pump change direction.
92. Mark the spots on the pattern to indicate whether the pump was at the top or bottom of the stroke during the pour.

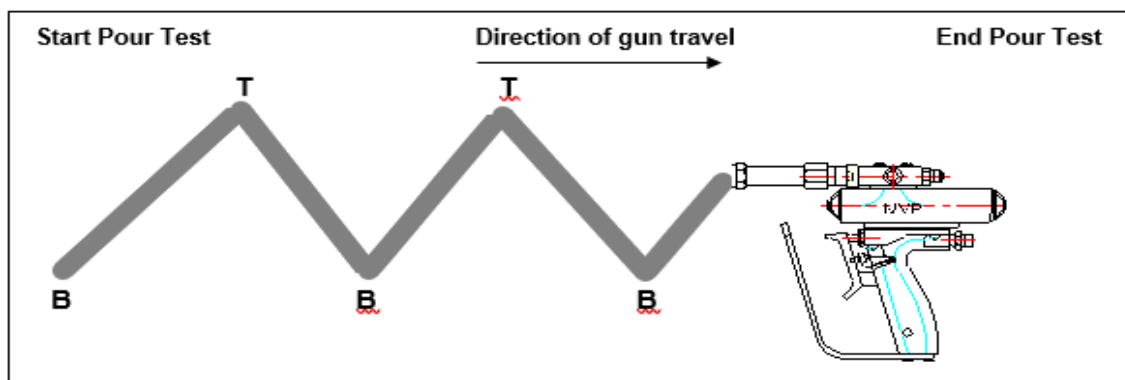

93.

Evaluate and Troubleshoot

Note *Depending on the length of the mixer there may be a delay in the metering issue and where it appears in the pattern.*

94. If the bead of material is uniform in color and curing correctly, proceed with dispensing material as needed for your job and skip to shut down instructions.
95. If the pour test material does not appear to be curing uniformly, follow the guidelines in the following table to correct the issue:

Pour Test Adjustments

If you see:	Indicates	Possible Cause	Solution
Material delivered on the activator pump down stroke is not curing or is slow cure. See below.	No or low activator is being delivered on the down stroke.	Worn or damaged intake valve.	Replace worn and damaged parts.
		Worn or damaged lower seat.	Replace worn and damaged parts.
		Dirty or stuck intake valve.	Clean or replace parts as needed.

Example:

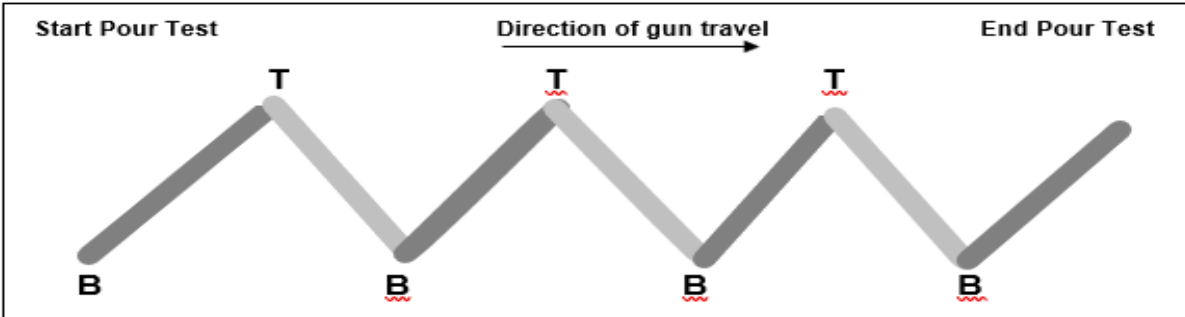

Material delivered on the activator pump up stroke is not curing or is slow cure. See below.	No or low activator is being delivered on the up stroke.	Worn or damaged piston seal.	Replace worn or damaged parts.
		Worn or damaged piston body ball.	Replace worn or damaged parts.
		Damaged piston body ball seat.	Replace worn or damaged parts.

Example:

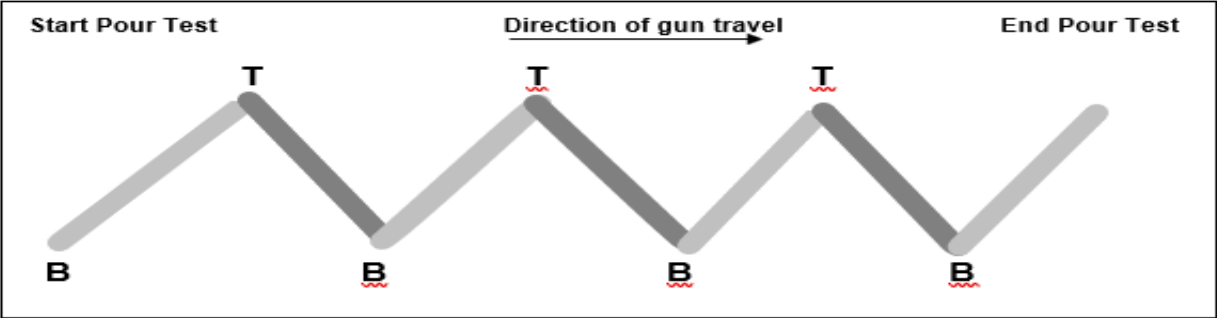

Material delivered at the top and bottom of the stroke is not curing or curing slower than the material delivered in the middle of the up and down stroke. See below.	Low or no activator at the top and bottom of the pump stroke.	There is no or improper accumulator effect in the activator system. Normally this is only a problem at high pressures.	Check to be sure you are using the proper activator hose and it is the proper length.
			Check for a restriction in the activator system.
Material delivered at the top and bottom of the stroke is hot (curing very rapidly). Thin areas of	Low resin at the top and bottom of the pump stroke.	There is no or improper accumulator effect in the adhesive system.	Check to be sure you are using the proper adhesive hose and it is the proper length.

material may be noticeable compared to volume in the middle of the stroke. See below.			Check for a restriction in the adhesive system.
Material delivered at the beginning of the down stroke is not curing normally. Also thin areas of material may be noticeable compared to the volume in the middle of the stroke. See below.	Low material delivery at the beginning of the pump stroke. Which pump depends on if it is curing slower or faster. Slow cure indicates less activator; fast cure means less adhesive.	The pump fluid section is not being filled correctly.	Increase ram/air lift pressure slightly until the issue goes away.
			Check that priming piston, priming seal, and relief washer are functioning correctly.

Example:

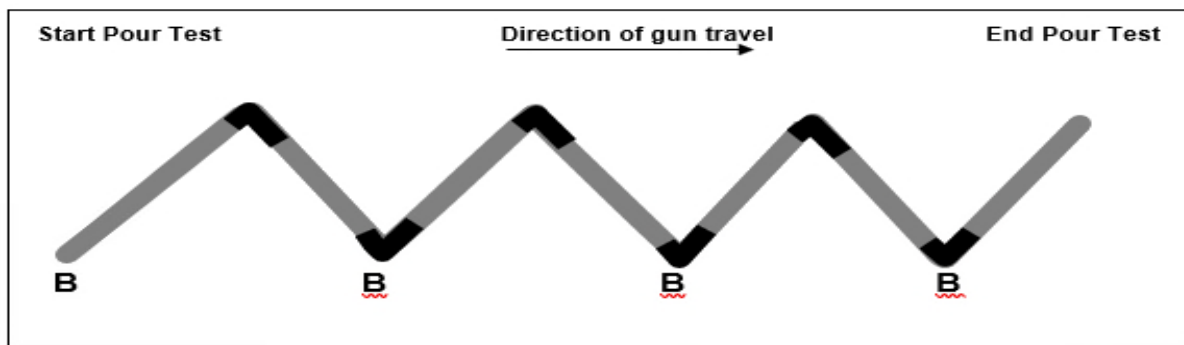

Flushing and Shutting Down

96. Open the dispensing head/gun momentarily and allow putty pump shaft to run to the fully lowered position.
97. Close the dispensing head/gun all the way.
98. Position the outlet of the mixer into an approved waste container.
99. Properly flush/air purge the mix chamber and mixer assembly.
100. Depending on the mixer assembly installed, remove the mix chamber and push out the mixer elements into a container for cleaning.
101. Use a bottle brush to clean out the mixer housing and clean the mixer elements by hand., as appropriate.
102. Clean out the outlet ports as much as possible in the dispensing head with solvent and brush.
103. Inspect the mixer elements for wear and breakage and replace as necessary.
104. Turn off the main air to the system and clean the dispense head/gun handle.
105. Relieve the air pressure from the flush tank by lifting the relief valve ring.

Changing an Empty Drum

- 106. Position the drum catch by sliding it over the base of the drum rim.
- 107. Move the ram control lever to the neutral (center) position.
- 108. Open the ball valve connected to the ram extraction gauge.
- 109. Slowly turn up the ram extraction regulator to 35 psi (2.4 bar).
- 110. Move the ram control lever to the up position.
- 111. Adjust the air lift pressure regulator to 20 psi (1.4 bar).
- 112. Close and open the ram control lever intermittently to raise the follow and pump out of the drum, holding the drum down if it begins to lift.

Note *It may be necessary to adjust both the air lift and ram extraction pressures to facilitate removal without lifting the drum.*

- 113. After pump and follower are removed, inspect, seal, and dispose of protective boot.
- 114. Clean any buildup of material from piston seals and follower plate.

Note *If seals need to be replaced, refer to the information in the table below.*

Application	Seal No.	Item	Seal Material	Seal OD	Backup Ring	Item
Polyester Putty	60520-3	29	Urethane – Red – Standard	22.56"		
	60520-1	29	EPDM – Black – Optional	22.56"	60510-1	64
	60520-5	29	Leather – Brown – Optional	22.56"	60510-1	64

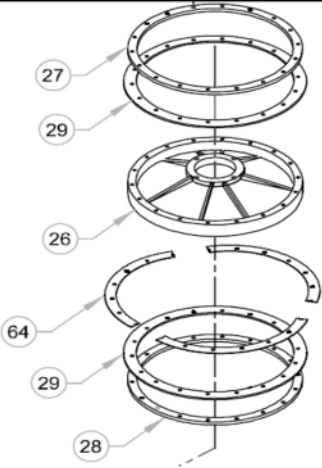

Figure 3. Piston Seals

- 115. Replace the container with a full drum and return to the steps for [Priming the Unit](#).

Performing Daily Tasks

Daily Start Up

116. Check and refill all components and materials.
117. Close the relief valve on the flush tank lid.
118. Open the lockout ball valve to pressurize the system.
119. Open the catalyst recirculation valve and then hand pump catalyst jug until the flow is air-free.
120. Close the catalyst recirculation valve and hand pump catalyst to pressurize system.
121. Watch the catalyst pressure gauge to make sure pressure is rising on both the up and down strokes.
122. Install the catalyst injector and mix chamber.
123. Prepare the mixer as follows:
 - *If you have a pour gun:* Reassemble and attach the static mixer assembly.
 - *If you have a spray gun:* Reassemble and attach the mixer housing and nozzle, then connect the air supply to the splatter nozzle.
124. Check the flush system for proper operation.
125. Push the priming button to pressurize the pump.

Daily Shut Down

126. Drain the water trap filter.
127. Thoroughly flush the gun.
128. Remove the static mixers as follows:
 - *If you have a pour gun:* Remove the static mixer tube and push the four static mixers out of the tube.
 - *If you have a spray gun:* Disconnect the air supply to the splatter nozzle. Remove and disassemble the mixer housings and push the static mixers out of the housings.
129. Clean the mixers and mix tube.
130. Remove the mix housing from the gun block and clean.
131. Close the lockout ball valve to relieve air pressure from the system.
132. Lift the relief valve on the flush tank lid to release flush tank pressure.
133. Open and then close the catalyst recirculation valve on the catalyst manifold to relieve the catalyst pressure.

Note ***Do not leave the barrel piston in the material if the system will be idle for more than 2 weeks.***

System Components

Systems can be configured differently from the base lists below. Refer to the serial plates on system components to verify part numbers when ordering repair kits or replacement parts.

All service and repair manuals are available on our website at <https://www.mvpind.com/application-support/technical-documents/>.

IMP-CCP-MP

Core System Parts	
Part Number	Description
HCHP-023J3J-30	Catalyst Hose Assembly
PF-HN-12S-08	Pipe Fitting
PCN-RAM-1	Single Ram Control Panel
F-LW-08	Lock Washer
F-HN-08C	Hex Nut
F-HB-08C-16	Hex Bolt
MPM-2583-1	Natural Poly – 3/8
MS-2052-1	.250" Natural Poly
CM-4000-SS-HP	Manifold Assembly
60531-1	Putty Piston Boot
01768	Hose Assembly
01449	.250" Orange Poly
01444	.250" Green Poly
01443	.250" Yellow Poly
PHPC-7200-M	Catalyst Pump Assembly
PCN-1005	Auxiliary Panel Bracket
CJ-2000-4-RS	2 Gallon Catalyst Jug Assembly
APD-1500-P	Putty Piston Assy
60625-1	Manual Gun Block – HV Putty
06688	Ball Valve
PF-ME-16J-12	Male Elbow
PF-HN-16-12	Hex Nipple
PF-FT-12	Tee
CM-BRKT-1	Mounting Bracket – Cat Manifold
CCP1001-1	Decal
APD-1006	Catalyst Jug Mounting Bracket
6101-01-01	Flush Tank Assembly – 3 Gal
CCP-29100	Pump Assy W/ Powerhead
APD-1000-BASE	Basic Ram Frame Assy
06289	U-Bolt

Parts Drawings

The illustrations on the following pages are included based on the components ordered with your system and will assist with assembly and repair.

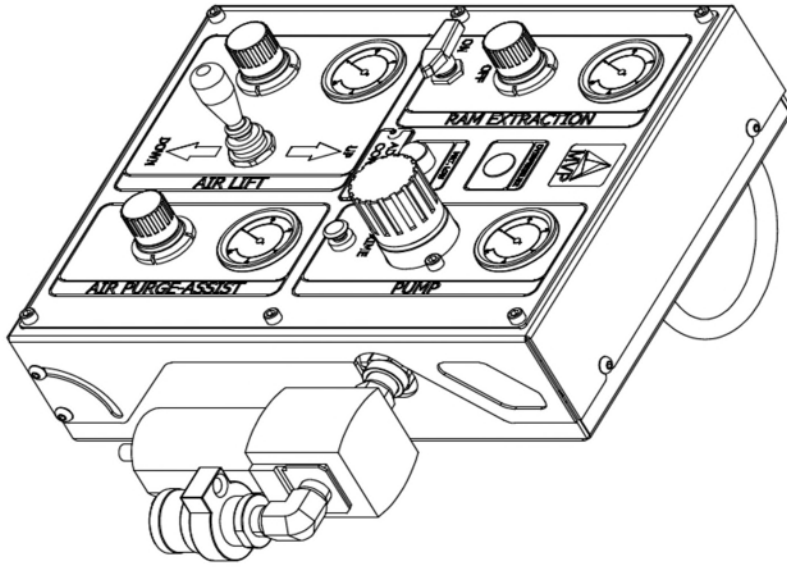

REVISION HISTORY		
REV	DESCRIPTION	DATE
-	INITIAL RELEASE	
		APPROVED

 <p>MAGNUM VENUS PRODUCTS CORPORATE HEADQUARTERS TECHNOLOGY CENTER 1801 KENT ROAD KNOXVILLE, TN 37922 865.866.5670</p>		<p>CONTRACT NO. 253384-2640</p>	
<p>UNLESS OTHERWISE SPECIFIED ALL DIMENSIONS ARE IN INCHES</p> <p>DECIMALS: XX ± .010 XX ± .005 XX ± .005</p> <p>FRACTIONS: 1/16, 1/8, 1/4, 1/2, 3/4, 1, 1 1/2, 2, 3, 4, 5, 6, 8, 10, 12, 16, 20, 24, 30, 36, 48, 60, 72, 96, 120, 144, 180, 240, 300, 360, 480, 600, 720, 960, 1200</p> <p>ALL DIMENSIONS ARE TO CENTER UNLESS OTHERWISE SPECIFIED BREAK SHARP EDGES .005 MAX RADIUS .005 X 45° MAX CHAMFER</p>		<p>TOLERANCES: ALL DIMENSIONS ARE IN INCHES</p> <p>DECIMALS: XX ± .010 XX ± .005 XX ± .005</p> <p>FRACTIONS: 1/16, 1/8, 1/4, 1/2, 3/4, 1, 1 1/2, 2, 3, 4, 5, 6, 8, 10, 12, 16, 20, 24, 30, 36, 48, 60, 72, 96, 120, 144, 180, 240, 300, 360, 480, 600, 720, 960, 1200</p> <p>ALL DIMENSIONS ARE TO CENTER UNLESS OTHERWISE SPECIFIED BREAK SHARP EDGES .005 MAX RADIUS .005 X 45° MAX CHAMFER</p>	
DESIGNED BY	DESIGNED	DATE	
STARTLETON	STARTLETON	12/2/2016	
PROJECT		SHEET	
PCN-RAM-1		1 OF 6	
PROJECT		REV	
ASSEMBLY			

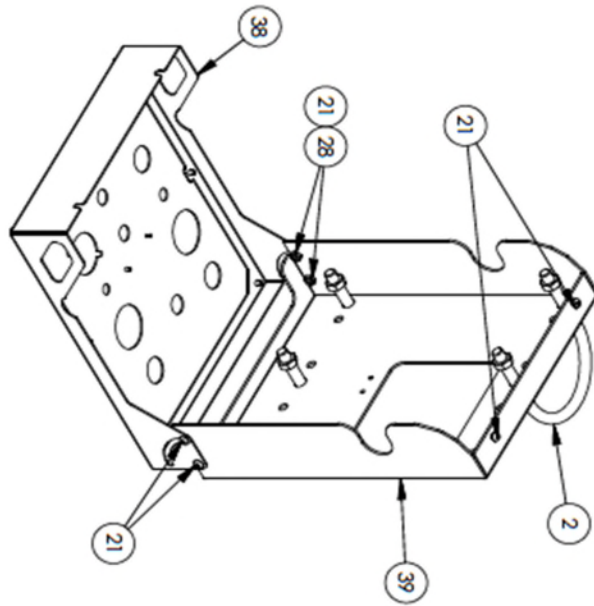
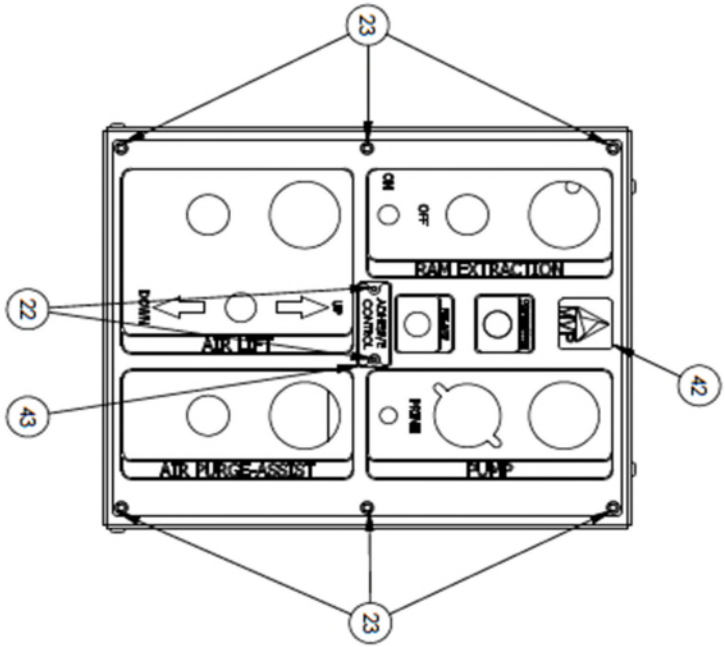

NOTES:
 APPLY LOCITITE TO ALL FASTENERS EXCEPT MOUNTING U BOLTS

QTY	ITEM #	PART NUMBER	DESCRIPTION
1	43	PCN-1007	ADHESIVE BADGE
1	42	PCN-1006	LASER ETCHED PANEL FACE
1	39	PCN-1002	PANEL BACK PLATE
1	38	PCN-1001	PANEL FRONT
4	28	F-8N-04C	HEX NUT
6	23	F-8S-04C-06	SOCKET HEAD CAP SCREW
2	22	F-8HCS-892-06	BUTTON HEAD CAP SCREW
6	21	F-8HCS-04C-08	BUTTON HEAD CAP SCREW
2	2	30289	5 U BOLT



MAGNUM VENUS PRODUCTS
 CORPORATION HEADQUARTERS
 12225 HERRING WAY SUITE 200
 ROCKWELL, TX 79787
 817.354.5400

TECHNOLOGY CENTER
 1842 TOWN AVENUE
 ROCKWELL, TX 79787
 817.354.5400

ASSEMBLY

REVISION: 12/27/2016

DATE: 10/11/16

BY: [Signature]

APPROVED: [Signature]

DATE: 07/11/17

DATE: 08/14/16

DATE: 05/14/16

DATE: 05/14/16

PRODUCT: **SINGLE RAM CONTROL PANEL, MAIN UNIT**

COMP NO: **PCN-RAM-1**

SHEET: **2 OF 6**

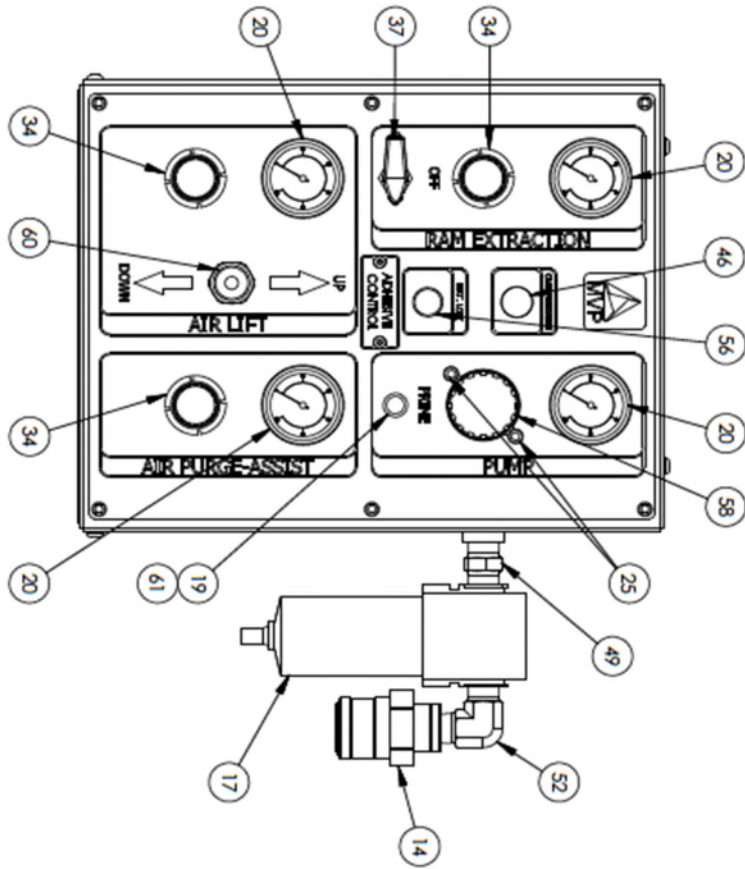

QTY	ITEM	PART NUMBER	DESCRIPTION
1	61	PNE-VRN-101	PANEL NUT
1	60	PNE-TOG-106-3P	LEVER TOGGLE VALVE - 3 POSITION
1	58	PNE-REG-101	REGULATOR
1	55	PNE-IND-102	RED/GREEN INDICATOR
2	52	PE-AE-08	MALE ELBOW
1	49	PE-INV-08	HEX NUT
1	46	PCN-1010	ENCLOSURE PLUG
1	37	WVD-1017	BALL VALVE
3	34	NV-CB-RG-1	250F REGULATOR
2	25	FC-SM-16	HEX SOCKET CAP SCREW - M8X16C
4	20	AG-PR2-100-P	PANEL MOUNT GAUGE
1	19	8407-5-1	PUSH BUTTON
1	17	8404-1-1	FILTER
1	14	07327	SLIDE VALVE

MAGNUM VENUS PRODUCTS
COMPANY OFFICE
 10001 WOODBURN AVENUE
 WOODBURN, VA 20182

COMPANY SALES
 10001 WOODBURN AVENUE
 WOODBURN, VA 20182

COMPANY FAX
 10001 WOODBURN AVENUE
 WOODBURN, VA 20182

REMARKS:
 UNLESS OTHERWISE SPECIFIED
 ALL DIMENSIONS ARE IN INCHES

ASSEMBLY

DATE: 12/27/2016

BY: [Signature]

DESCRIPTION:
 SINGLE RAM CONTROL PANEL MAIN UNIT

PROJECT: PCN-RAM-1

DATE: 3 OF 6

REV: 1

This document is the property of MVP. Distribution, reproduction, disclosure or use by others, in part or in whole, is not permitted without the written consent of MVP. All rights reserved.

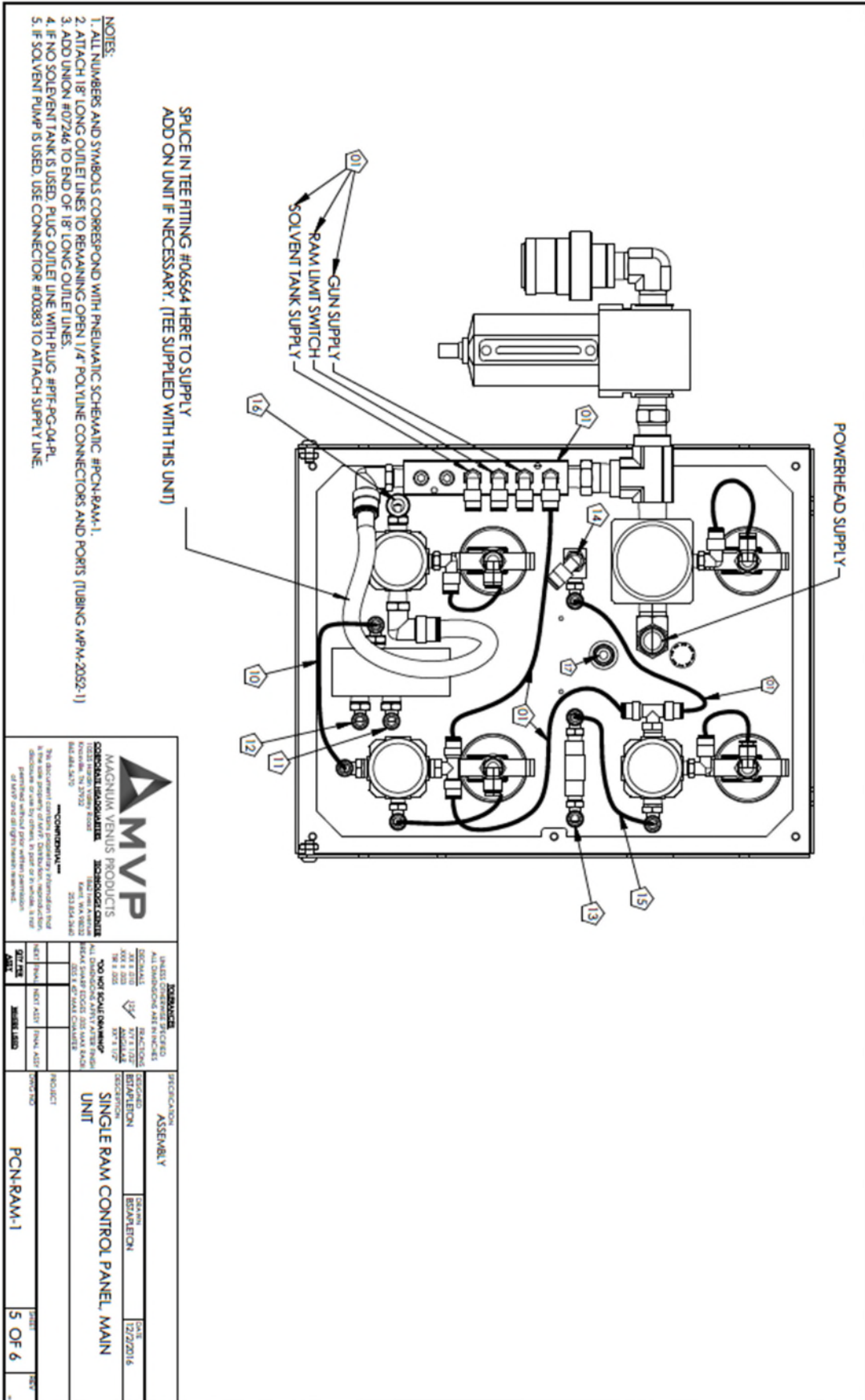

 <p>MVP MAGNUM VENUS PRODUCTS</p> <p>CONSUMER PRODUCTS 2300 S. 20th Street Knox, TN 37722 800.828.2462</p> <p>COMMERCIAL 2015 S. 24th Street Knox, TN 37722 202.834.2462</p> <p><small>This document is the property of MVP. Distribution, reproduction, or disclosure of this document, in part or in whole, is not permitted without prior written permission. ©2015 MVP. All rights reserved.</small></p>		<p>UNITS OPERATED BY:</p> <p>DISCOUNTS: <input type="checkbox"/> 5% OFF 10% OFF 15% OFF 20% OFF</p> <p>NO PORTS TO BE OPENED!</p> <p>BEAK SWAP FROM 200 KPAV KAVH 200 KPAV KAVH EXCHANGER</p>	
		<p>ASSEMBLY</p> <p>DATE: 12/22/2016</p> <p>REVISION: 1</p> <p>DESCRIPTION: SINGLE RAM CONTROL PANEL, MAIN UNIT</p>	
<p>DATE: 12/22/16</p> <p>BY: [Signature]</p> <p>APPROVED: [Signature]</p>	<p>PROJECT: PCN-RAM-1</p> <p>PAGE: 5 OF 6</p>		

CM-4000-SS-HP
MANIFOLD ASSEMBLY
05-24-18 (JCH)

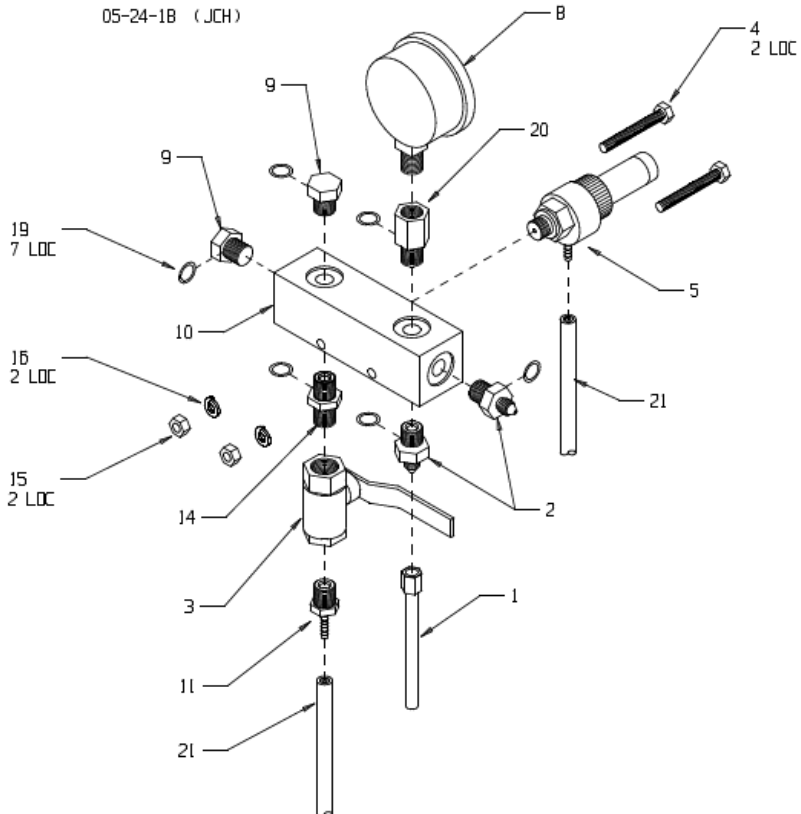

**CM-4000-SS-HP
CATALYST MANIFOLD ASSEMBLY
05-24-18
CUSTOMER PARTS KEY**

ITEM	PART #	DESCRIPTION	QTY
1	HCSS-0203J-3	CAT. HOSE	1
2	CM-1052	FITTING	2
3	BV-44-XHP-SS	BALL VALVE	1
4	F-HB-04C-32	BOLT	2
5	RV-1000-2500	2500# RELIEF VALVE	1
8	MRO-1005-3000	3000# GAUGE	1
9	CM-1053	PLUG	2
10	CM-1051-SS	MANIFOLD BLOCK	1
11	CPRV-1002-A	FITTING	1
14	CM-1056	FITTING	1
15	F-HN-04C	NUT	2
16	F-SW-04	SPLIT WASHER	2
19	O-S-013	O-RING	6
20	CM-1055	FITTING	1
21	MS-2052-30IN	TUBE	2

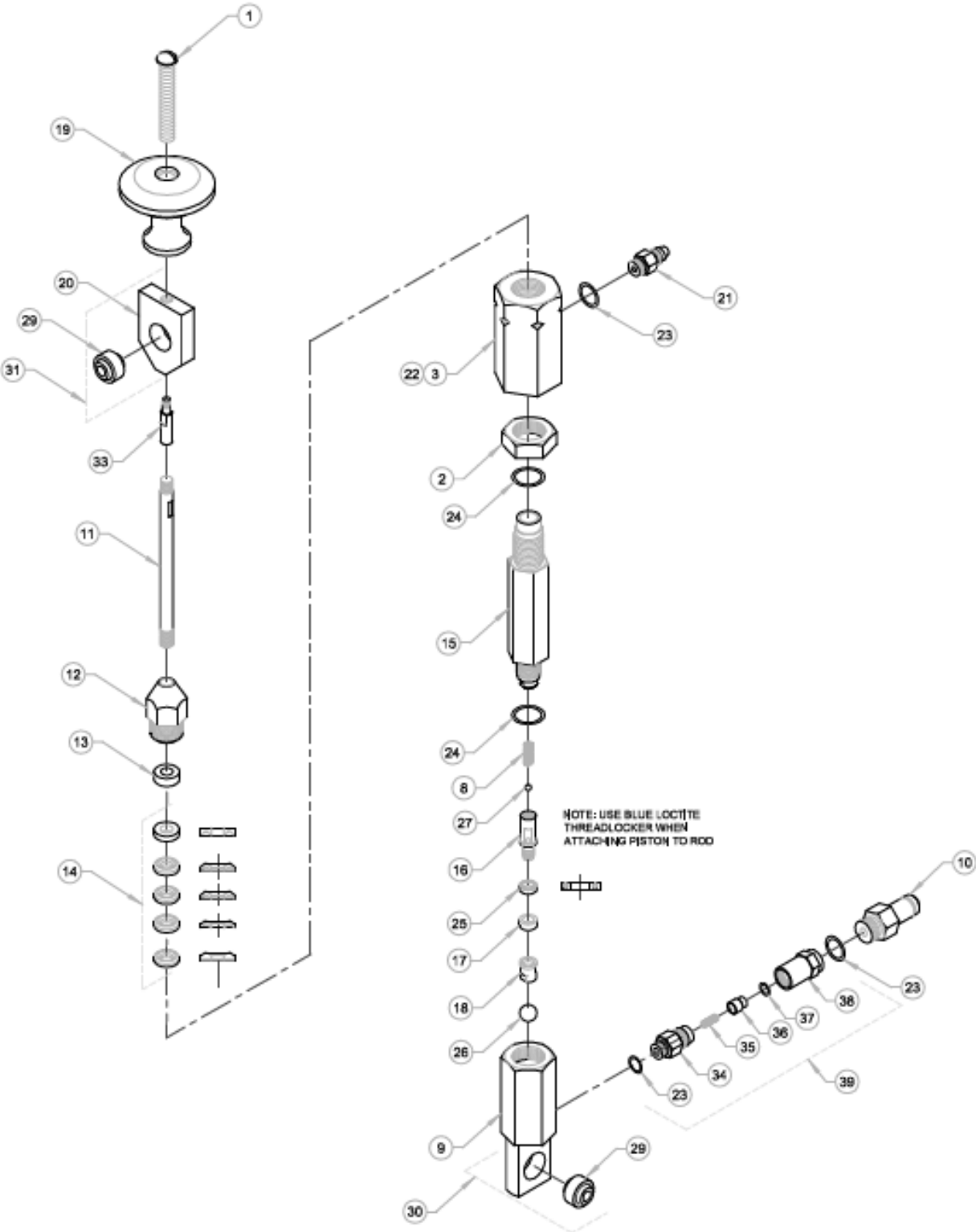

MAGNUM VENUS PLASTECH

ASSEMBLY - PUTTY CATALYST PUMP - MEKP PHPC-7200-M

REV. B = DELETED ITEMS 5, 6, 7, 32, ITEM 21 WAS 51704-1, ADDED CV-2000 AND ALL OF ITS COMPONENTS
REV. C = ITEM 37 WAS O-S-011 03/08/06 BT2
REV. D = ITEM 24 WAS 7301-9-014 03/03/11 BT2
REV. E = ADDED THREADLOCKER NOTE 02/20/14 BT2



PUTTY CATALYST PUMP - MEKP PHPC-7200-M**PARTS LIST**

ITEM	PART NO.	QTY	DESCRIPTION
1	02849-16	1	SLOTTED MACHINE SCREW
2	4101-1-1	1	LOCKNUT
3	4101-14-1	1	OUTLET BODY
8	4101-3-1	1	PISTON ROD SPRING
9	4101-7-1	1	INLET BODY
10	4101-8-1	1	INLET TUBE FITTING
11	4102-2-1	1	PISTON ROD
12	4102-3-1	1	PACKING NUT
13	4102-4-1	1	UPPER GUIDE
14	4102-5-01	1	PACKING SET SPA
15	4102-6-1	1	CYLINDER
16	4102-7-1	1	PISTON BODY
17	4102-8-1	1	PISTON GUIDE
18	4102-9-1	1	SEAL RETAINER
19	50100-1	1	PRIMING KNOB
20	50210-1	2	BEARING BLOCK
21	51501-1	1	OUTLET FITTING
22	6701-24-EN	1	PUMP SEAL WARNING LABEL
23	O-S-013	3	O - RING
24	O-S-014	2	O - RING
25	7304-1-1	1	PISTON SEAL
26	9201-1-14	1	7/16" SS BALL
27	9201-1-5	1	5/32" SS BALL
29	9202-1-1	2	SPHERICAL BEARING
33	CCP-1004	1	PISTON ROD EXTENSION
34	CV-2002	1	SPRING HOUSING
35	CV-2004	1	SPRING
36	CV-2003	1	PISTON
37	O-S-011A	1	O-RING
38	CV-2001	1	SEAT HOUSING

REPAIR KITS

PART NO.	DESCRIPTION
VHPC-1000-RK	REPAIR KIT

OPTIONAL PARTS & ASSEMBLIES

30	4101-7-01	1	INLET BODY W/ BEARING
31	50210-3	1	BEARING BLOCK W/ BEARING
39	CV-2000	1	CHECK VALVE

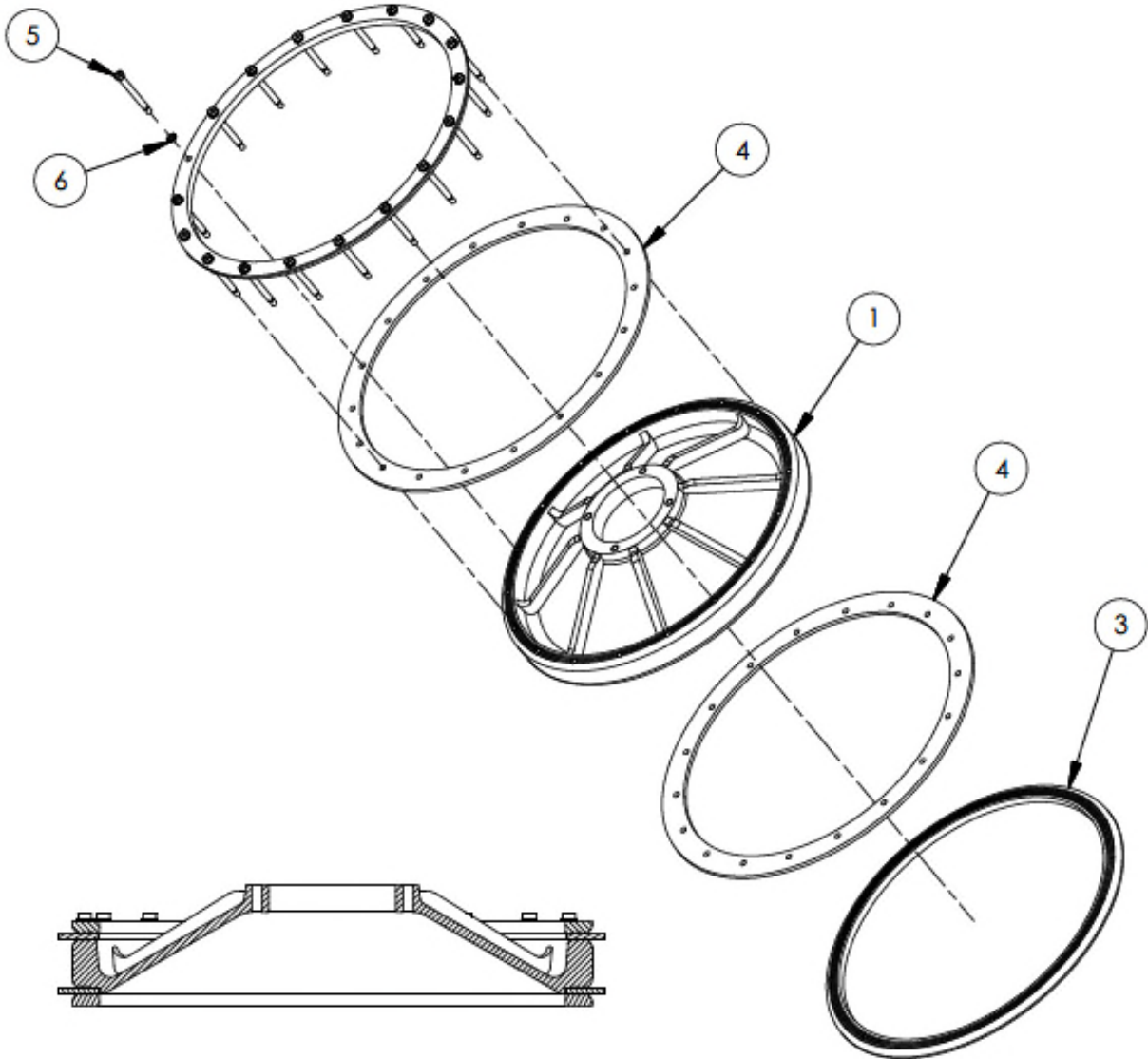

Parts List			
ITEM	PART NUMBER	QTY	DESCRIPTION
6	60521-1	18	SPACER
5	02685-24	18	SHOULDER BOLT
4	60520-3	2	BARREL SEAL
3	60519-5	1	BOTTOM RING
2	60519-13	1	TOP RING
1	60519-11	1	BARREL PISTON

MAGNUM VENUS PRODUCTS

PUTTY PISTON ASSEMBLY	APD-1500-P
-----------------------	------------

REV: A 11/05/2019

SHEET 1 / 1

7/15/2016



DETAIL A
CHECK VALVE FLOW
ARROW TOWARD TANK

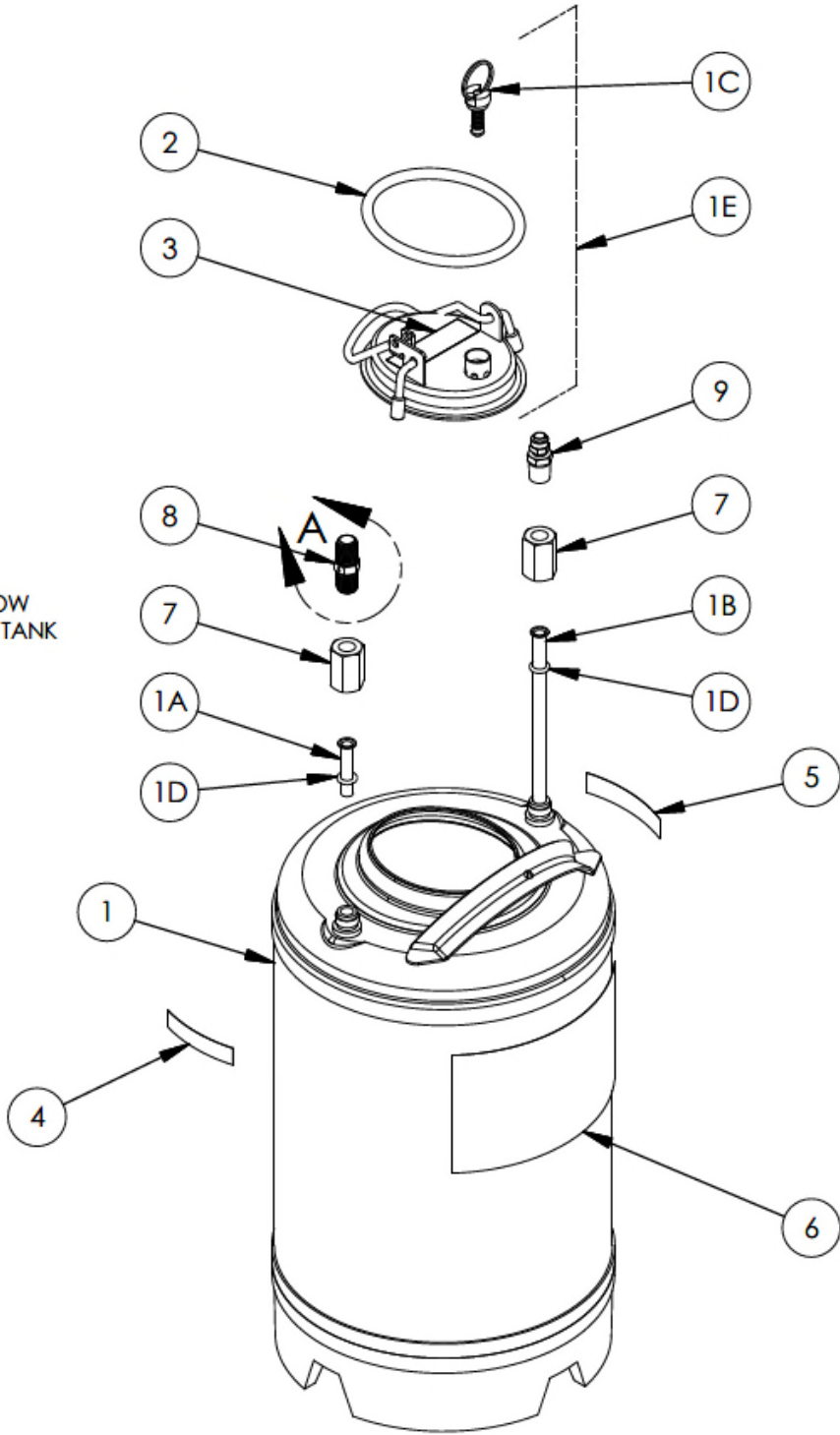

MAGNUM VENUS PRODUCTS

FLUSH TANK ASSEMBLY - 3 GALLON	6101-01-01
--------------------------------	------------

REV:

SHEET 1 / 2

6/30/2020

Parts List			
ITEM	PART NUMBER	QTY	DESCRIPTION
1	8703-2-1	1	3 GALLON FLUSH TANK
2	O-E-5-381	2	O-RING (1 SPARE INCLUDED)
3	6701-12-EN	1	FLUSH TANK DECAL PRESSURE RELIEF INSTRUCTION
4	6701-13-EN	1	FLUSH TANK DECAL AIR
5	6701-14-EN	1	FLUSH TANK DECAL SOLVENT
6	95172-EN	1	FLUSH TANK DECAL
7	55210-3	2	FLUSH TANK FITTING
8	CV-04-101	1	1 PSI CHECK VALVE
9	00383	1	MALE CONNECTOR

Parts Included in 8703-2-1			
ITEM	PART NUMBER	QTY	DESCRIPTION
1A	8703-3-1	1	INLET TUBE
1B	8703-4-1	1	OUTLET TUBE
1C	8703-5-1	1	RELIEF VALVE
1D	O-E-109	2	O-RING
1E	6101-02-01	1	LID ASSEMBLY

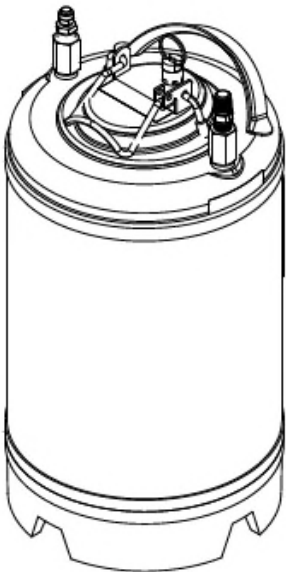

MAGNUM VENUS PRODUCTS

FLUSH TANK ASSEMBLY - 3 GALLON	6101-01-01
--------------------------------	------------

REV:

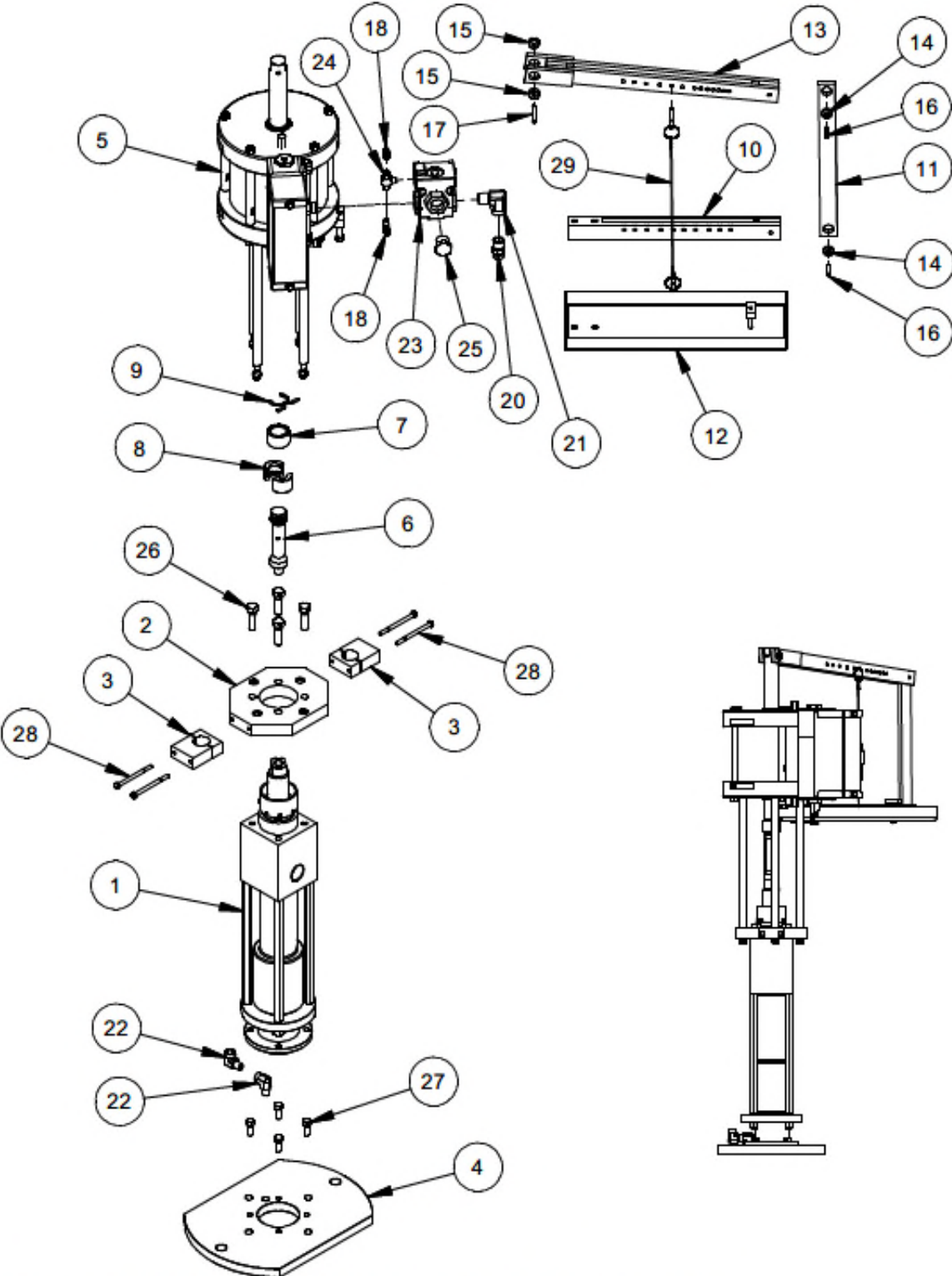

MAGNUM VENUS PLASTECH

CHOP CHECK PUMP ASSEMBLY	CCP-29100
--------------------------	-----------

REV: A = VPH-7000-P-HD WAS VPH-7000-P, VLS-4613-HD WAS VLS-4613, ADDED PAT-PA-9110, VPH-10009, PAT-PA-9112 3/9/09 MDW

Parts List			
ITEM	PART NUMBER	QTY	DESCRIPTION
1	CCPLS-1000	1	FLUID SECTION ASSY.
2	CCP-1008	1	PUMP MOUNT PLATE
3	CCP-1007	2	SUPPORT BRACKET
4	CCP-1009	1	SUPPORT PLATE
5	VPH-7000-P-HD	1	7" POWER HEAD ASSY. - HD
6	VLS-4613-HD	1	PISTON ROD ADAPTER - HD
7	PAT-PA-9110	1	SHELL RETAINER
8	VPH-10009	2	HALF SHELL
9	PAT-PA-9112	1	SLEEVE CLIP
10	CCP-1006	1	LOWER SLAVE ARM
11	CCP-1005	1	CONNECTING BAR
12	CCP-1003-01	1	DRIP TRAY ASSY.
13	86480-1	1	UPPER SLAVE WELD.
14	03501-1	2	BUSHING
15	03502-1	2	BEARING - UPPER SLAVE ARM
16	F-RP-04-20	2	ROLL PIN
17	F-RP-04-32	1	ROLL PIN
18	MPH-2534	2	POLY ELBOW
20	PF-HN-08-08S	1	HOSE ADAPTER
21	PF-SE-08	1	STREET ELBOW
22	PF-SE-04	2	STREET ELBOW
23	8407-1-1	1	VALVE
24	8407-3-1	1	SHUTTLE VALVE
25	PF-HP-12	1	HEX PLUG
26	F-HB-08C-28-GR8	4	HEX BOLT
27	F-HB-06C-16	4	HEX BOLT
28	F-HB-04C-56	4	HEX BOLT
29	52106-1	1	QUICK PIN CABLE

MAGNUM VENUS PLASTECH

CHOP CHECK PUMP ASSEMBLY

CCP-29100

REV: A = VPH-7000-P-HD WAS VPH-7000-P, VLS-4613-HD WAS VLS-4613, ADDED PAT-PA-9110, VPH-10009, PAT-PA-9112 3/9/09 MDW



Magnum Industries Europe Ltd. t/a Magnum Venus Products

Official Distributor of MVP Range in the United Kingdom and Ireland

Unit 22a, Navigation Drive, Hurst Business Park,
Brierley Hill, West Midlands, DY5 1UT, UK.

phone: +44 (0)1384 486222
email: info@mvpeurope.co.uk
website: www.mvpeurope.co.uk