

# Pro Pump Component Manual

This manual is applicable to the following models:

- VPRO-45110
- VPRO-45110-FP
- VPRO-45110-IM
- VPRO-45110-QS
- VPRO-25400
- VPRO-25400-FIT
- VPRO-45220
- VPRO-45220-IM
- VPRO-45220-MC
- VPRO-45220-NPR
- VPRO-25700

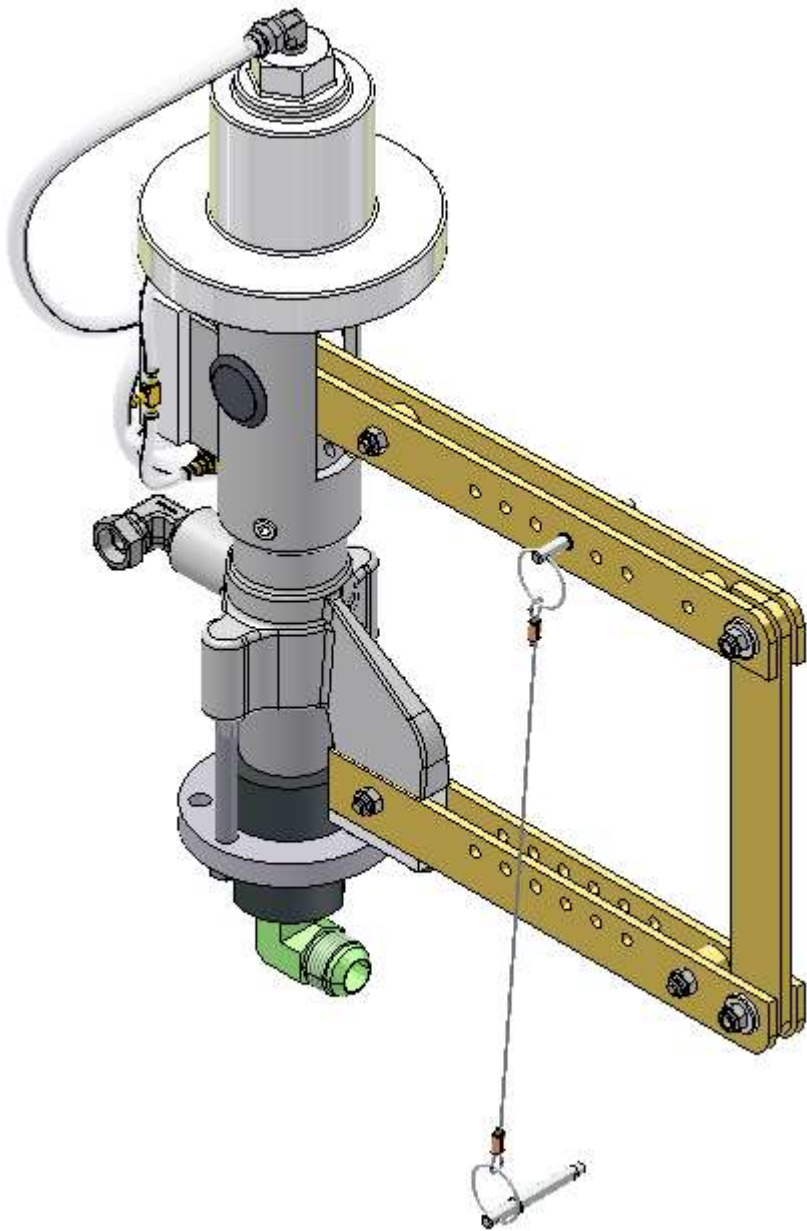



**Magnum Industries Europe Ltd. t/a Magnum Venus Products**

*Official Distributor of MVP Range in the United Kingdom and Ireland*

Unit 22a, Navigation Drive, Hurst Business Park,  
Brierley Hill, West Midlands, DY5 1UT, UK.

**phone:** +44 (0)1384 486222  
**email:** [info@mvpeurope.co.uk](mailto:info@mvpeurope.co.uk)  
**website:** [www.mvpeurope.co.uk](http://www.mvpeurope.co.uk)



# Table of Contents

<b>Section</b>	<b>Page</b>
• <b>Table of Contents</b>	<b>3</b>
• <b>Safety &amp; Warning Information</b>	<b>4</b>
• <b>Introduction</b>	<b>15</b>
• <b>Disassembling Pump</b>	<b>17</b>
• <b>Reassembling Pump</b>	<b>23</b>
• <b>Maintaining Pump</b>	<b>26</b>
• <b>Troubleshooting</b>	<b>27</b>
• <b>Parts Drawings</b>	<b>29</b>

# Safety & Warning Information

## Warnings

Due to the vast number of chemicals that could be used and their varying chemical reactions, the buyer and user of this equipment should determine all factors relating to the fluids used, including any of the potential hazards involved. Particular inquiry and investigation should be made into potential dangers relating to toxic fumes, fires, explosions, reaction times, and exposure of human beings to the individual components or their resultant mixtures. MVP assumes no responsibility for loss, damage, expense or claims for bodily injury or property damage, direct or consequential, arising from the use of such chemical components.

The end user is responsible for ensuring that the end product or system complies with all the relevant laws in the country where it is to be used and that all documentation is adhered to.

### Recommended Occupational Safety & Health Act (OSHA) Documentation:

- 1910.94                      Pertaining to ventilation
- 1910.106                    Pertaining to flammable liquids
- 1910.107                    Pertaining to spray finishing operations, particularly paragraph (m), Organic Peroxides and Dual Component Coatings

For Additional information, contact the Occupational Safety and Health Administration (OSHA) at <https://www.osha.gov/about.html>.

### Recommended National Fire Protection Association (NFPA) Documentation:

- NFPA No.33 Chapter 14                      Organic Peroxides and Dual Component Materials
- NFPA No. 63                                    Dust Explosion Prevention
- NFPA No. 70                                    National Electrical Code
- NFPA No. 77                                    Static Electricity
- NFPA No. 91                                    Blower and Exhaust System
- NFPA No. 654                                    Plastics Industry Dust Hazards

**Fire Extinguisher** – code ABC, rating number 4a60bc using Extinguishing Media –Foam, Carbon Dioxide, Dry Chemical, Water Fog, is recommended for this product and applications.

The following general warnings and guidelines are for the setup, use, grounding, maintenance, and repair of equipment. Additional product-specific warnings may be found throughout this manual as applicable. Please contact your nearest MVP Technical Service Representative if additional information is needed.

## Safety Precautions

- Avoid skin contact and inhalation of all chemicals.
- Review Material Safety Data Sheet (MSDS) to promote the safe handling of chemicals in use.
- Restrict the use of all chemicals to designated areas with good ventilation.
- Chemicals are flammable and reactive.
- Noxious fumes released when combusted.
- Operate equipment in a ventilated environment only.
- Uncured liquid resins are highly flammable unless specifically labeled otherwise.
- Cured laminate, accumulations of overspray, and laminate sandings are highly combustible.
- Do not operate or move electrical equipment when flammable fumes are present.
- Ground all equipment.
- If a spark is seen or felt, immediately halt operation. Do not operate the equipment until the issue has been identified and repaired.
- Contaminated catalyst may cause fire or explosion.
- Containers may explode if exposed to fire / heat.
- Use and store chemicals away from heat, flames, and sparks.
- Do not smoke in work areas or near stored chemicals.
- Do not mix Methyl Ethyl Ketone Peroxide (MEKP) with materials other than polyethylene.
- Do not dilute MEKP.
- Keep food and drink away from work area.



**Physical Hazards**

- Never look directly into the spray gun fluid tip. Serious injury or death can result.
- Never aim the spray gun at or near another person. Serious injury or death can result.
- Chemical compounds can be severely irritating to the eyes and skin.
- Inhalation, ingestion, or injection may damage internal organs and lead to pulmonary disorders, cancers, lymphomas, and other diseases or health conditions.
- Other potential health effects include: irritation of the eyes and upper respiratory tract, headache, light-headedness, dizziness, confusion, drowsiness, nausea, vomiting, and occasionally abdominal pain.
- Eye contact: Immediately flush with water for at least 15 minutes and seek immediate medical attention.
- Skin Contact: Immediately wash with soap and water and seek immediate medical attention.
- Inhalation: Move the person to fresh air and seek immediate medical attention.
- Do not remove shields, covers, or safety features on equipment that is in use.
- Never place fingers, hands, or any body part near or directly in front of the spray gun fluid tip. The force of the liquid as it exits the spray tip can shoot liquid through the skin.
- Keep hands and body parts away from any moving equipment or components.
- Do not stand under plunger
- An improperly loaded drum may lead to an imbalance, causing a unit to tip over

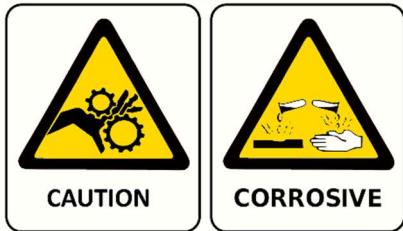

**Personal Protective Equipment (PPE)**

- MVP recommends the use of personal safety equipment with all products in our catalog.
- Wear safety goggles, hearing protection, a respirator, and chemical resistant gloves.
- Wear long sleeve shirts or jackets and pants to minimize skin exposure.
- PPE should be worn by operators and service technicians to reduce the risk of injury.



For Additional information, contact the Occupational Safety and Health Administration (OSHA). <https://www.osha.gov/about.html>

## Symbol Definitions



Indicates the risk of contact with chemicals that are hazardous, which may lead to injury or death.



Indicates the risk of contact with voltage / amperage that may lead to serious injury or death.



Indicates that the materials being used are susceptible to combustion.



Indicates the risk of contact with moving components that may lead to serious injury or death.



Indicates that the system or component should be grounded before proceeding with use or repair.



Indicates the use of lit cigarettes or cigars is prohibited, because the materials being used are susceptible to combustion.



Indicates that the materials and/or the process being performed can lead to ignition and explosion.



A recommendation for the use of Personal Protective Equipment (PPE) before using or repairing the product.

## Polymer Matrix Materials: Advanced Composites

Potential health hazards associated with the use of advanced composites can be controlled through the implementation of an effective industrial hygiene and safety program.

[https://www.osha.gov/dts/osta/otm/otm\\_iii/otm\\_iii\\_1.html#t\\_iii:1\\_1](https://www.osha.gov/dts/osta/otm/otm_iii/otm_iii_1.html#t_iii:1_1)

<b>Resins</b>		
<b>Composite Component</b>	<b>Organ System Target (Possible Target)</b>	<b>Known (Possible) Health Effect</b>
Epoxy resins	Skin, lungs, eyes	Contact and allergic dermatitis, conjunctivitis
Polyurethane resins	Lungs, skin, eyes	Respiratory sensitization, contact dermatitis, conjunctivitis
Phenol formaldehyde	Skin, lungs, eyes	As above (potential carcinogen)
Bismaleimides (BMI)	Skin, lungs, eyes	As above (potential carcinogen)
Polyamides	Skin, lungs, eyes	As above (potential carcinogen)
<b>Reinforcing materials</b>		
<b>Composite Component</b>	<b>Organ System Target (Possible Target)</b>	<b>Known (Possible) Health Effect</b>
Aramid fibers	Skin (lungs)	Skin and respiratory irritation, contact dermatitis (chronic interstitial lung disease)
Carbon/graphite fibers	Skin (lungs)	As noted for aramid fibers
Glass fibers (continuous filament)	Skin (lungs)	As noted for aramid fibers
<b>Hardeners and curing agents</b>		
<b>Composite Component</b>	<b>Organ System Target (Possible Target)</b>	<b>Known (Possible) Health Effect</b>
Diaminodiphenylsulfone	N/A	No known effects with workplace exposure
Methylenedianiline	Liver, skin	Hepatotoxicity, suspect human carcinogen
<b>Other aromatic amines</b>		
<b>Composite Component</b>	<b>Organ System Target (Possible Target)</b>	<b>Known (Possible) Health Effect</b>
Meta-phenylenediamine (MPDA)	Liver, skin (kidney, bladder)	Hepatitis, contact dermatitis (kidney and bladder cancer)
Aliphatic and cyclo-aliphatic amines	Eyes, skin	Severe irritation, contact dermatitis
Polyaminoamide	Eyes, skin	Irritation (sensitization)
Anhydride	Eyes, lungs, skin	Severe eye and skin irritation, respiratory sensitization, contact dermatitis

## Catalyst - Methyl Ethyl Ketone Peroxide (MEKP)

MEKP is among the more hazardous materials found in commercial channels. The safe handling of the “unstable (reactive)” chemicals presents a definite challenge to the plastics industry. The highly reactive property which makes MEKP valuable to the plastics industry in producing the curing reaction of polyester resins also produces the hazards which require great care and caution in its storage, transportation, handling, processing and disposal. MEKP is a single chemical. Various polymeric forms may exist which are more or less hazardous with respect to each other. These differences may arise not only from different molecular structures (all are, nevertheless, called “MEKP”) and from possible trace impurities left from the manufacture of the chemicals, but may also arise by contamination of MEKP with other materials in its storage or use. Even a small amount of contamination with acetone, for instance, may produce an extremely shock-sensitive and explosive compound.



### **WARNING**

***Contamination with promoters, materials containing promoters (such as laminate sandings), or with any readily oxidizing material (such as brass or iron) will cause exothermic redox reactions which can be explosive in nature. Heat applied to MEKP or heat buildup from contamination reactions can cause the material to reach its Self-Accelerating Decomposition Temperature (SADT).***

Researchers have reported measuring pressure rates-of-rise well over 100,000 psi per second when certain MEKP's reach their SADT. For comparison, the highest-pressure rate-of-rise listed in NFPA Bulletin NO.68, “Explosion Venting”, is 12,000 psi per second for an explosion of 12% acetylene and air. The maximum value listed for a hydrogen explosion is 10,000 psi per second. Some forms of MEKP, if allowed to reach their SADT, will burst even an open topped container. This suggests that it is not possible to design a relief valve to vent this order of magnitude of pressure rate-of-rise. The user should be aware that any closed container, be it a pressure vessel, surge chamber, or pressure accumulator, could explode under certain conditions. There is no engineering substitute for care by the user in handling organic peroxide catalysts. If, at any time, the pressure relieve valve on top of the catalyst tank should vent, the area should be evacuated at once and the fire department called. The venting could be the first indication of a heat, and therefore, pressure build-up that could eventually lead to an explosion. Moreover, if a catalyst tank is sufficiently full when the pressure relief valve vents, some catalyst may spray out, which could cause eye injury. For this reason, and many others, anyone whose job puts them in an area where this vented spray might go, should always wear full eye protection even when laminating operations are not taking place.

Safety in handling MEKP depends to a great extent on employee education, proper safety instructions, and safe use of the chemicals and equipment. Workers should be thoroughly informed of the hazards that may result from improper handling of MEKP, especially regarding contamination, heat, friction and impact. They should be thoroughly instructed regarding the proper action to be taken in the storage, use, and disposal of MEKP and other hazardous materials used in the laminating operation. In addition, users should make every effort to:

- Store MEKP in a cool, dry place in original containers away from direct sunlight and away from other chemicals.
- Keep MEKP away from heat, sparks, and open flames.
- Prevent contamination or MEKP with other materials, including polyester over spray and sandings, polymerization accelerators and promoters, brass, aluminum, and non-stainless steels.

- Never add MEKP to anything that is hot, since explosive decomposition may result.
- Avoid contact with skin, eyes, and clothing. Protective equipment should be worn at all times. During clean-up of spilled MEKP, personal safety equipment, gloves, and eye protection must be worn. Firefighting equipment should be at hand and ready.
- Avoid spillage, which can heat up to the point of self-ignition.
- Repair any leaks discovered in the catalyst system immediately, and clean-up the leaked catalyst at once in accordance with the catalyst manufacturer's instructions.
- Use only original equipment or equivalent parts from Magnum Venus Products in the catalyst system (i.e.: hoses, fitting, etc.) because a dangerous chemical reaction may result between substituted parts and MEKP.
- Catalyst accumulated from the purging of hoses or the measurement of fluid output deliveries should never be returned to the supply tank, such catalyst should be diluted with copious quantities of clean water and disposed of in accordance with the catalyst manufacturer's instructions.

The extent to which the user is successful in accomplishing these ends and any additional recommendations by the catalyst manufacturer determines largely the safety that will be present in his operation.

## Clean-Up Solvents and Resin Diluents



### **WARNING**

***A hazardous situation may be present in your pressurized fluid system! Hydro carbon solvents can cause an explosion when used with aluminum or galvanized components in a closed (pressurized) fluid system (pump, heaters, filters, valves, spray guns, tanks, etc.). An explosion could cause serious injury, death, and/or substantial property damage. Cleaning agents, coatings, paints, etc. may contain Halogenated Hydrocarbon solvents. Some Magnum Venus Products spray equipment includes aluminum or galvanized components and will be affected by Halogenated Hydrocarbon solvents.***

There are three key elements to the Halogenated Hydrocarbon (HHC) solvent hazard.

- |    |   |  |
|----|---|--|
| 1. | The presence of HHC solvents.               | 1,1,1 – Trichloroethane and Methylene Chloride are the most common of these solvents. However, other HHC solvents are suspect if used; either as part of paint or adhesives formulation, or for clean-up flushing.   |
| 2. | Aluminum or Galvanized Parts.               | Most handling equipment contains these elements. In contact with these metals, HHC solvents could generate a corrosive reaction of a catalytic nature.   |
| 3. | Equipment capable of withstanding pressure. | When HHC solvent contact aluminum or galvanized parts inside a closed container such as a pump, spray gun, or fluid handling system, the chemical reaction can, over time, result in a build-up of heat and pressure, which can reach explosive proportions. When all three elements are present, the result can be an extremely violent explosion. The reaction can be sustained with very little aluminum or galvanized metal; any amount of aluminum is too much. |

- The reaction is unpredictable. Prior use of an HHC solvent without incident (corrosion or explosion) does NOT mean that such use is safe. These solvents can be dangerous alone (as a clean-up or flushing agent) or when used as a component or a coating material. There is no known inhibitor that is effective under all circumstances. Mixing HHC solvents with other materials or solvents such as MEKP, alcohol, or toluene may render the inhibitors ineffective.
- The use of reclaimed solvents is particularly hazardous. Reclaimers may not add any inhibitors. The possible presence of water in reclaimed solvents could also feed the reaction.
- Anodized or other oxide coatings cannot be relied upon to prevent the explosive reaction. Such coatings can be worn, cracked, scratched, or too thin to prevent contact. There is no known way to make oxide coatings or to employ aluminum alloys to safely prevent the chemical reaction under all circumstances.
- Several solvent suppliers have recently begun promoting HHC solvents for use in coating systems. The increasing use of HHC solvents is increasing the risk. Because of their exemption from many state implementation plans as Volatile Organic Compounds (VOCs), their low flammability hazard, and their not being classified as toxic or carcinogenic substances, HHC solvents are very desirable in many respects.



### **WARNING**

***Do not use Halogenated Hydrocarbon (HHC) solvents in pressurized fluid systems having aluminum or galvanized wetted parts.***

***Magnum Venus Products is aware of NO stabilizers available to prevent HHC solvents from reaction under all conditions with aluminum components in closed fluid systems. HHC solvents are dangerous when used with aluminum components in a closed fluid system.***

- Consult your material supplier to determine whether your solvent or coating contains Halogenated Hydrocarbon solvents.
- Magnum Venus Products recommends that you contact your solvent supplier regarding the best non-flammable clean-up solvent with the heat toxicity for your application.
- If, however, you find it necessary to use flammable solvents, they must be kept in approved, electrically grounded containers.
- Bulk solvent should be stored in a well-ventilated, separate building, 50 feet away from your main plant.
- You should only allow enough solvent for one day's use in your laminating area.
- NO SMOKING signs must be posted and observed in all areas of storage or where solvents and other flammable materials are used.
- Adequate ventilation (as covered in OSHA Section 1910.94 and NFPA No.91) is important wherever solvents are stored or used, to minimize, confine and exhaust the solvent vapors.
- Solvents should be handled in accordance with OSHA Section 1910.106 and 1910.107.

## Catalyst Diluents

Magnum Venus Products spray-up and gel-coat systems currently produced are designed so that catalyst diluents are not required. Magnum Venus Products therefore recommends that diluents not be used to avoid possible contamination which could lead to an explosion due to the handling and mixing of MEKP and diluents. In addition, it eliminates any problems from the diluent being contaminated through rust particles in drums, poor quality control on the part of the diluents suppliers, or any other reason. If diluents are absolutely required, contact your catalyst supplier and follow his instructions explicitly. Preferably the supplier should premix the catalyst to prevent possible “on the job” contamination while mixing.



### **WARNING**

***If diluents are not used, remember that catalyst spillage and gun, hose, and packing leaks are potentially more hazardous since each drop contains a higher concentration of catalyst and will therefore react more quickly with overspray and the leak.***

## Cured Laminate, Overspray and Laminate Sandings Accumulation

- Remove all accumulations of overspray, Fiberglass Reinforced Plastic (FRP) sandings, etc. from the building as they occur. If this waste is allowed to build up, spillage of catalyst is more likely to start a fire; in addition, the fire would burn hotter and longer.
- Floor coverings, if used, should be non-combustible.
- Spilled or leaked catalyst may cause a fire if it comes in contact with an FRP product, oversprayed chop or resin, FRP sandings or any other material with MEKP.

To prevent spillage and leakage, you should:

- |  |   |
|--|---|
| 1. Maintain your Magnum Venus Products System.   | Check the gun several times daily for catalyst and resin packing or valve leaks. REPAIR ALL LEAKS IMMEDIATELY.  |
| 2. Never leave the gun hanging over or lying inside the mold.  | A catalyst leak in this situation would certainly damage the part, possibly the mold, and may cause a fire.   |
| 3. Inspect resin and catalyst hoses daily for wear or stress at the entry and exits of the boom sections and at the hose and fittings. | Replace if wear or weakness is evident or suspected.  |
| 4. Arrange the hoses and fiberglass roving guides so that the fiberglass strands DO NOT rub against any of the hoses at any point.     | If allowed to rub, the hose will be cut through, causing a hazardous leakage of material which could increase the danger of fire. Also, the material may spew onto personnel in the area. |

## Toxicity of Chemicals

- Magnum Venus Products recommends that you consult OSHA Sections 1910.94, 1910.106, 1910.107 and NFPA No.33, Chapter 14, and NFPA No.91.
- Contact your chemical supplier(s) and determine the toxicity of the various chemicals used as well as the best methods to prevent injury, irritation and danger to personnel.
- Also determine the best methods of first aid treatment for each chemical used in your plant.

## Equipment Safety

Magnum Venus Products suggest that personal safety equipment such as EYE GOGGLES, GLOVES, EAR PROTECTION, and RESPIRATORS be worn when servicing or operating this equipment. Ear protection should be worn when operating a fiberglass chopper to protect against hearing loss since noise levels can be as high as 116 dB (decibels). This equipment should only be operated or serviced by technically trained personnel!



### CAUTION

***Never place fingers, hands, or any body part near or directly in front of the spray gun fluid tip. The force of the liquid as it exits the spray tip can cause serious injury by shooting liquid through the skin. NEVER LOOK DIRECTLY INTO THE GUN SPRAY TIP OR POINT THE GUN AT OR NEAR ANOTHER PERSON OR AN ANIMAL.***



### DANGER

***Contaminated catalyst may cause fire or explosion. Before working on the catalyst pump or catalyst accumulator, wash hands and tools thoroughly. Be sure work area is free from dirt, grease, or resin. Clean catalyst system components with clean water daily.***



### DANGER

***Eye, skin, and respiration hazard. The catalyst MEKP may cause blindness, skin irritation, or breathing difficulty. Keep hands away from face. Keep food and drink away from work area.***

## Treatment of Chemical Injuries



### CAUTION

***Refer to your catalyst manufacturer's safety information regarding the safe handling and storage of catalyst. Wear appropriate safety equipment as recommended.***

Great care should be used in handling the chemicals (resins, catalyst and solvents) used in polyester systems. Such chemicals should be treated as if they hurt your skin and eyes and as if they are poison to your body. For this reason, Magnum Venus Products recommends the use of protective clothing and eye wear in using polyester systems. However, users should be prepared in the event of such an injury.

**Precautions include:**

1. Know precisely what chemicals you are using and obtain information from your chemical supplier on what to do in the event the chemical gets onto your skin or into the eyes, or if swallowed.
2. Keep this information together and easily available so that it may be used by those administering first aid or treating the injured person.
3. Be sure the information from your chemical supplier includes instructions on how to treat any toxic effects the chemicals have.

**WARNING**

**Contact your doctor immediately in the event of an injury. If the product's MSDS includes first aid instructions, administer first aid immediately after contacting a doctor.**

Fast treatment of the outer skin and eyes that contact chemicals generally includes immediate and thorough washing of the exposed skin and immediate and continuous flushing of the eyes with lots of clean water for at least 15 minutes or more. These general instructions of first aid treatment may be incorrect for some chemicals; you must know the chemicals and treatment before an accident occurs. Treatment for swallowing a chemical frequently depends upon the nature of the chemical.

**Emergency Stop Procedure**

In an emergency, follow these steps to stop a system:

1. The ball valve located where the air enters the power head of the resin pump, should be moved to the "OFF" or closed position.

**Note**     **The "open" or "on" position is when the ball valve handle is parallel (in line) with the ball valve body. The "closed" or "off" position is when the ball valve handle is perpendicular (across) the ball valve body.**

2. Turn all system regulators to the "OFF" position (counter-clockwise) position.
3. Verify / secure the catalyst relief line, located on the catalyst relief valve.
4. Verify / secure the resin return line, located on the resin filter.
5. Place a container under the resin pump ball valve to catch ejected resin.
6. Locate the ball valve on the resin pump.
7. Rotate the ball valve 90 degrees to the "On" or open position.

**Grounding**

Grounding an object means providing an adequate path for the flow of the electrical charge from the object to the ground. An adequate path is one that permits charge to flow from the object fast enough that it will not accumulate to the extent that a spark can be formed. It is not possible to define exactly what will be an adequate path under all conditions since it depends on many variables. In any event, the grounding means should have the lowest possible electrical resistance.

Grounding straps should be installed on all loose conductive objects in the spraying area. This includes material containers and equipment. Magnum Venus Products recommends grounding straps be made of AWG No.18 stranded wire as a minimum and the larger wire be used where possible. NFPA Bulletin No77 states that the electrical resistance of such a leakage path should be 1 meg ohm ( $10^6$  ohms) or less.



### CAUTION

***Whenever flammable or combustible liquids are transferred from one container to another, or from one container to the equipment, both containers or container and equipment shall be effectively bonded and grounded to dissipate static electricity. For further information, see National Fire Protection Association (NFPA) 77, titled “Recommended Practice on Static Electrical”. Refer especially to section 7-7 titled “Spray Application of Flammable and Combustible Materials”.***

## Introduction

This manual provides information for the maintenance and simple repair of the MVP Pro Pump. The following procedures are included:

- Step-by-step assembly and disassembly
- Troubleshooting information
- Maintenance schedule



Please read this manual carefully and retain for future reference. Follow the steps in the order given, otherwise you may damage the equipment or injure yourself.

As you disassemble the equipment, lay out the components in the correct order and direction to assist with reassembly. Take specific note of the order of the piston cup, piston cup spacer ring, piston cup backup ring, and compression ring and the directions they face. Orienting these parts correctly is critical to proper function of the pump.

## Lubrication

Throughout this manual directions are given for lubricating various parts of the pump. There are three types of lubricant used:

- If the part contacts resin, use MVP Red Grease
- If the part is located where it will contact air, use Lubriplate®
- In the reservoir of the pump, use throat seal oil (TSL)



### DANGER

***Contaminated catalyst may cause fire or explosion. Do not use lubrication on components that contact catalyst. Refer to your manufacturer’s instructions for additional material handling information.***

## Components

Your Pro Pump consists of the following components:

- Resin pump fluid section
- Resin pump air motor
- Shift block assembly

## Requirements

When performing service and repair on the Pro Pump have the following tools, spare parts, and supplies available before beginning:

- TABLE VISE
- LOCTITE™ 243 (REMOVABLE) OR EQUIVALENT THREAD LOCK COMPOUND
- SMALL HAMMER
- NEEDLE-NOSE PLIERS
- SOLVENT OR EMULSIFIER FOR CLEANING
- CLEAN WORK TABLE
- ANTI-SEIZE THREAD SEALANT
- SET OF HEX WRENCHES
- 5/8-INCH WRENCH
- 9/16-INCH WRENCH
- 5/16-INCH WRENCH
- EMPTY BUCKETS FOR CLEANING
- CLEAN 1/4-INCH DOWEL OR ROD
- 8-INCH ADJUSTABLE WRENCH
- 12-INCH ADJUSTABLE WRENCH
- 7/16-INCH OPEN-END WRENCH
- 1/2-INCH SOCKET WRENCH
- WOODEN STICKS OR TONGUE DEPRESSORS FOR TESTING
- LABELS AND PENS FOR MARKING PNEUMATIC LINES
- CLEAN RAGS AND PAINT BRUSHES FOR CLEANING EQUIPMENT
- TUBE OF MEDIUM-WEIGHT LITHIUM GREASE (I.E. LUBRIPLATE®)
- LARGE (APPROX. 3 FT BY 10 FT) STRIPS OF PAPER FOR SPRAY TESTS
- PIN WRENCH (COMES WITH CATALYST JUG)
- SCRIBE
- RED GREASE
- SEAL KIT FOR YOUR MODEL

**Note**      ***Lubriplate® is a registered trademark of the Lubriplate division of Fiske Brothers Refining Company.***

**Note**      ***Loctite™ is a trademark of the Loctite Corporation.***

**Note**      ***Teflon® is a registered trademark of E.I. DuPont de Nemours and Co.***

**WARNING**

**Components used on this equipment are made of specially developed, high-strength material. Only authentic MVP replacement parts are acceptable for use with this equipment. Use of unacceptable replacement parts will void our liability and warranty of this equipment.**

**Contact your MVP representative for more information.**

## Disassembling Pump

**CAUTION**

**Always wear proper safety equipment (glasses, gloves, respirator, etc.) when working with dispensing equipment and before startup of the unit. Refer to and follow the requirements of the Material Safety Data Sheets (MSDS) supplied by your material manufacturer(s).**

**Note**     **Flushing the pump fluid section with solvent will make it easier to clean and rebuild.**

**Note**     **When disassembling the pump, replace any O-rings that you expose.**

1. Look up and refer to the current parts drawing for the particular pump you are working on.
2. Relieve all fluid and air pressure from the system.

**WARNING**

**To avoid serious injury or equipment damage do not proceed until the system has been completely depressurized.**

3. Unpin and remove the catalyst pump from the slave arms.

## Remove Pump from System

4. Remove the air hose connected to the fitting on the shift block assembly.
5. Remove the pick-up wand hose from the elbow at the bottom of the pump, if applicable.
6. Remove the resin hose from the fitting on the resin filter assembly, if applicable.
7. Remove the air tube from the elbow on top of the air motor assembly.
8. Remove the screws holding the gelcoat pump to the pump mount.

## Disassemble Foot Valve

9. Mount the pump in a vise, using care not to damage the equipment.
10. Make note of the position of the elbow on the foot valve body.

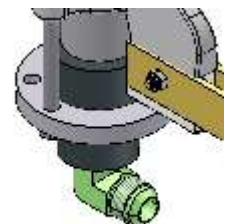

**Note**     ***When you reinstall the foot valve later the elbow must be oriented in the same position. Also take special note of the order of the piston cup, piston cup spacer, and compression ring. These directions are critical to proper functioning of the equipment.***

11. Use a wrench to remove the hex cap screws securing the cylinder and foot valve body to the center section of the pump.

**Note**     ***Loosen the screws alternately to prevent distorting them.***

12. Remove the foot valve body and the cylinder from the pump.
13. Separate the cylinder from the foot valve assembly by pulling them apart.
14. Inspect the cylinder for wear or damage; replace as needed.
15. Remove any built up material from the interior of the components.
16. Use needle-nose pliers to remove the ball stop from the interior of the foot valve.
17. Remove the spring and ball.

**Note**     ***Take care not to drop the ball. If a ball hits the floor it will be damaged; even if it appears undamaged, microscopic dents and scratches will create problems. Damaged balls must be replaced for proper operation of the pump.***

18. Check the interior of the foot valve for material buildup or damage; clean and replace as needed.



## Reassemble Foot Valve

19. Lubricate the foot valve ball with a light film of red grease.
20. Roll the ball into the foot valve body.

**Note**     ***Handle the foot valve ball carefully. If it is damaged it must be replaced.***

21. Insert the spring on top of the ball.
22. Use the ball stop to secure the foot valve spring and the foot valve ball in the foot valve body.

**Note**     ***The ball stop should be in the groove in the foot valve body, with the ball stop on top of the spring.***

23. Place new O-rings on the cylinder and lubricate them with red grease.
24. Insert the cylinder into the foot valve body.
25. Use the palm of your hand to press the cylinder securely into the foot valve until the cylinder seats.
26. Set the foot valve aside for now.

## Disassemble Piston Body

27. Remove the piston body.

**Note** *Hold your hand under the pump as you loosen the piston body to prevent the ball and piston ball spring from falling out.*

28. Inspect the ball and spring to ensure there is no damage; replace as needed.

**Note** *If the ball falls it must be replaced.*

29. Remove the spring retainer and lower packing spring.

30. Separate the piston cup backup ring, the piston cups, the piston cup spacer ring, and the compression ring.

31. Inspect components for wear and replace if necessary.

**Note** *The piston cups must be replaced each time the pump is disassembled.*



## Reassemble Piston Body

32. Lubricate the two piston cups with red grease.

33. Assemble the piston body components onto the piston body in the order they were removed and with the correct sides facing each other, as follows:

- Piston cup backup ring with grooved side facing up toward the pump
- Piston cup with the cup facing up
- Piston cup spacer ring (which separates the piston cups) with the grooved side up
- Second piston cup with the cup facing up
- Compression ring with beveled side facing down toward the bottom of the pump

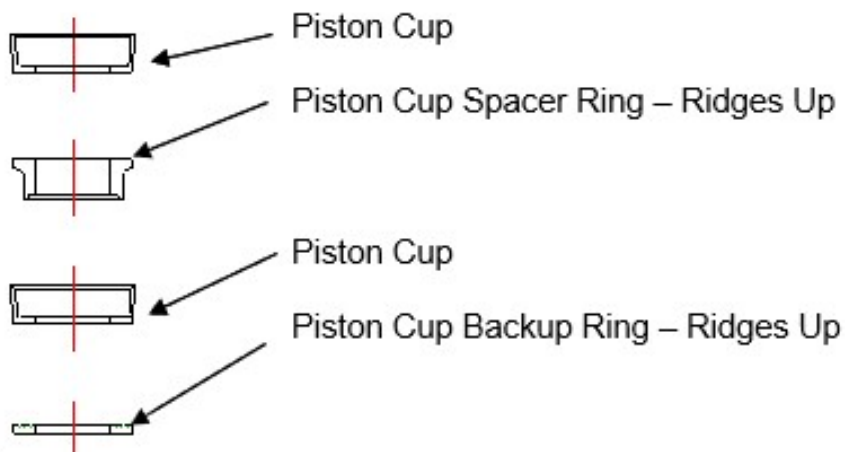

**Note** *Be sure the compression ring is positioned down over the shoulder of the piston body or the piston cups will not tighten properly.*

34. Keep the ball and piston ball spring with the assembly, but do not assemble onto the pump yet.

## Remove Packing Set

35. Place the pump in a vise by clamping onto the bottom slave arm, making sure the opening at the bottom of the center section is clear of the vise.
36. Remove the black plastic plugs in the side of the pump body.
37. Be sure the pump is set to mid-stroke.

**Note** *You should be able to access the hex screw and hex nut through the holes in the pump head. If the pump is not at mid-stroke, connect and slowly increase air to the pump until it reaches that position. Be sure you have a second air hose connected to the elbow on the shift block assembly, then disconnect the air.*

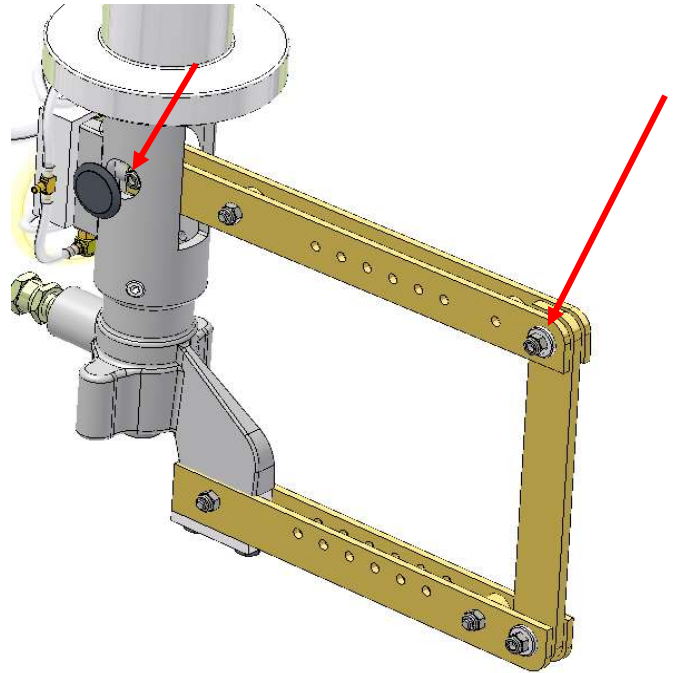

### **WARNING**

*Always disconnect air when instructed to do so to prevent injury or damage to the equipment.*

38. Use a wrench to hold the lock nut on the upper slave arm in position and use a second wrench to remove the hex cap screw securing the upper slave arm to the pump's center section.
39. Move the pump to the top of the stroke by hand or reconnect air to the pump.

**Note** *Be sure you have a second air hose connected to the elbow on the shift block assembly.*



### **CAUTION**

*Never insert fingers or tools into the pump cavity when air is connected to the pump. Serious injury or amputation could occur.*

40. Slowly increase the air pressure until the pump reaches the top of the stroke, then shut off the air.

41. Disconnect the air.
42. Insert the bottom of the clamshell tools around the piston rod, between the piston rod and center section, centering the tops under the hex screws on either side.
43. Reconnect air to the pump.
44. Slowly increase the air pressure until the hold for the hex screw appears, then shut off the air.
45. Disconnect the air.

## Connect Upper Slave Arm

46. Coat the slave arm hex screw with red grease.
47. Using the two wrenches, reinstall the hex screw and lock nut.
48. Install the plastic plug over the hole on the side of the pump's center section.



### **DANGER**

***Never operate the pump unless the plastic plugs are installed. Serious injury or amputation may occur.***

49. Push down on the slave arms and clamshells to remove the packing set from the bottom of the pump.

**Note** ***If you are unable to do so by hand, reconnect the air and slowly increase air pressure until the pump reaches the bottom of the stroke, then shut off the air and disconnect.***

**Note** ***If the packing set has not come down far enough, gently insert a blunt tool into the pump cavity and use it to drive the clamshells further down.***

50. Remove the male compression ring, piston rod packing set, and female compression ring from the bottom of the pump.
51. Remove the clamshells through the bottom of the center section.
52. Inspect the inside of the packing cavity and make sure it is clean and free of material.

## Remove Cylinder Head

53. Remove the air tube from the top of the pump air motor.
54. Use a wrench to unscrew the cylinder head.
55. Inspect the inside of the cylinder head for wear or damage.
56. Remove the O-ring from the air motor piston.
57. Remove the O-ring from the top of the center section casting.
58. Remove the hex nut from the top of the air motor piston.
59. Unscrew the air motor piston from the piston rod.



## Remove Shift Block & Valves

60. Remove the three hex screws holding the shift block to the pump while holding onto the shift valve to prevent it from falling.

**Note**     ***Do not remove the machine screws that hold the valve in place.***

61. Remove the urethane tubes from the operator valve body.  
62. Remove the two mufflers from the operator valve body.

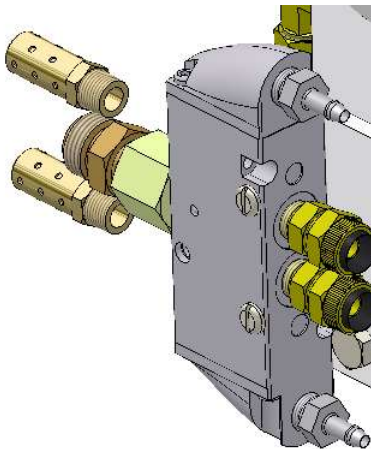

63. Unscrew the hose adapter and reducer from the operator valve body.  
64. Unscrew the two barbed tube fittings from the operator valve body.  
65. Remove the two machine screws from the operator valve body.

**Note**     ***The guard will also come loose when you remove the machine screws.***

66. Remove the operator valve and guard from the actuator body.  
67. Remove the urethane tube from the actuator valve body.  
68. Unscrew the elbow from the end of the actuator.  
69. Remove the cover from the actuator block.

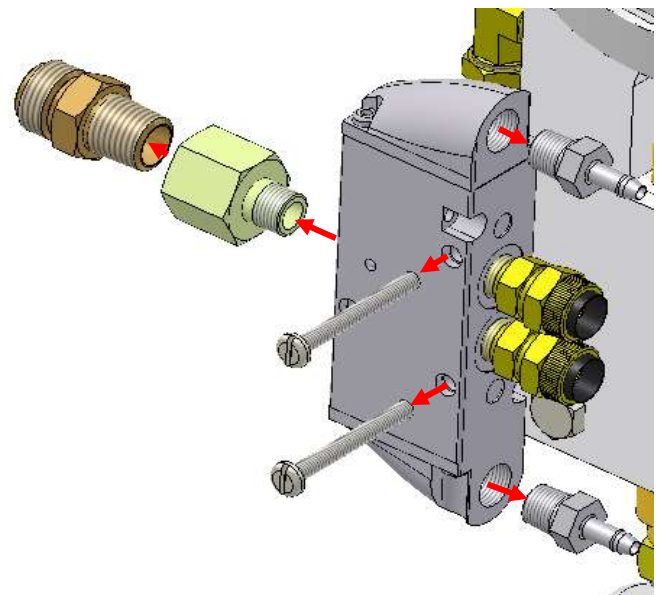
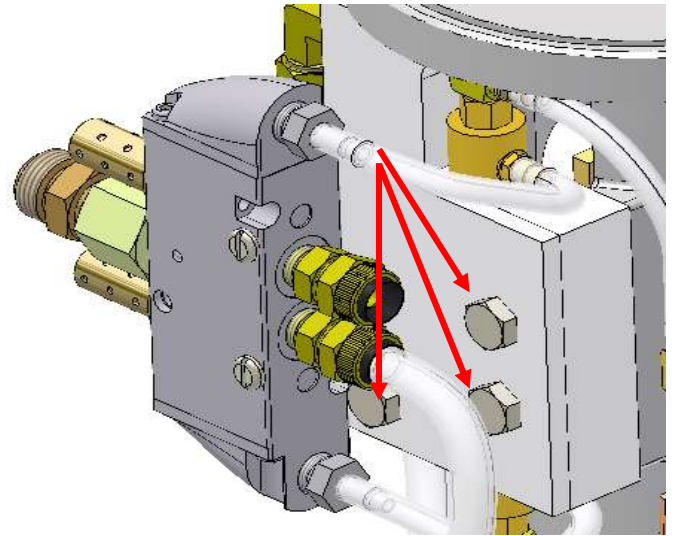

70. Remove the nut holding the actuator in place and pull the actuator free.
71. Repeat steps [67](#) - [70](#) for the other end if necessary.

## Remove Piston Rod

72. Remove the socket head cap screw and trip sleeve from the piston rod.
73. Check the cap screw to make sure it is not bent; replace as needed.
74. Use a wrench to hold the lock nut on the upper slave arm in position and use a second wrench to remove the hex cap screw securing the upper slave arm to the pump's center section.
75. Remove the piston rod and inspect for damage or wear; replace as needed.
76. Remove the O-ring from the bushing in the top of the center section.

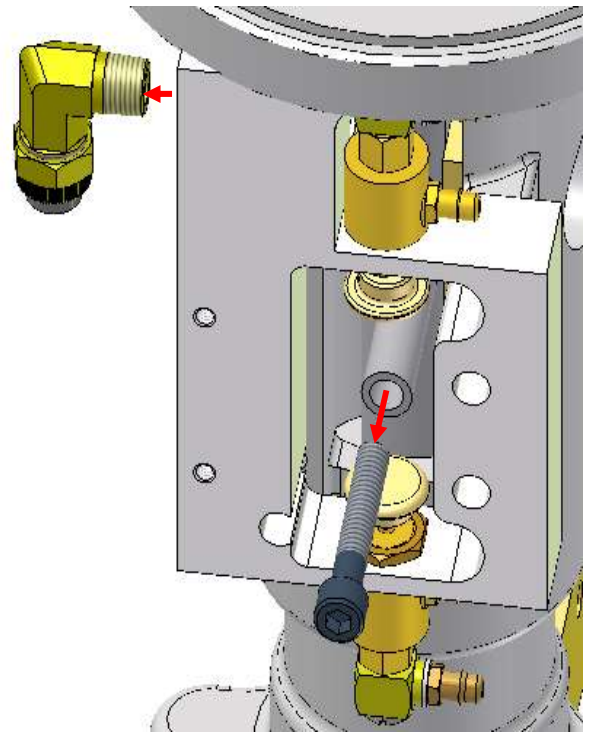

## Reassembling Pump

### Reinstall Piston Rod

1. Coat a new O-ring with red grease and install into the bushing on top of the center section.
2. Coat the top portion of the piston rod with red grease and install up through the center section, using care not to damage the newly installed O-ring.
3. Coat the hex screw with red grease.
4. Connect the upper slave arm to the piston rod by using the two wrenches to install the hex screw and lock nut.
5. Install the trip sleeve onto the socket head cap screw.
6. Put a drop of removable thread lock compound onto the threads of the socket head cap screw extending through the trip sleeve and then thread it into the piston rod.

### Install Cylinder Head

7. Be sure the pump is in the mid-stroke position.
8. Lubricate all of the following items with red grease:
  - O-ring on the piston
  - Piston rod above center section
  - Threads on center section where the cylinder head fits
  - O-ring on the top of the center section

- Inside of the cylinder head
9. Install the O-ring onto the air motor piston.
  10. Install the O-ring onto the top of the center section.
  11. Thread the air motor piston onto the piston rod and snug tight.
  12. Thread the hex nut onto the piston rod above the air motor piston and snug tight.
  13. Screw the cylinder head onto the center section and tighten.

## Install Packing Set

14. Lay the pump on its side to make it easier to insert the balls and springs.
15. Lubricate each packing and the female compression ring with red grease and assemble them as follows:
  - Female compression ring (top of stack), with the flat side toward the top of the pump and the concave side facing the packing set. Fill the concave side full of red grease.
  - Piston rod packing set; fill the inside of each packing with red grease and be sure to install them in the same order in which they were prior to being removed. The concave side of the packing should face toward the bottom of the pump.
  - Male compression ring (bottom of stack), with the lip facing away from the packing set and toward the spring.
  - Lower packing spring, with the smaller coil of the spring fitting over the lip of the male compression ring.
  - Spring retainer, with the lip in the larger coil of the spring.

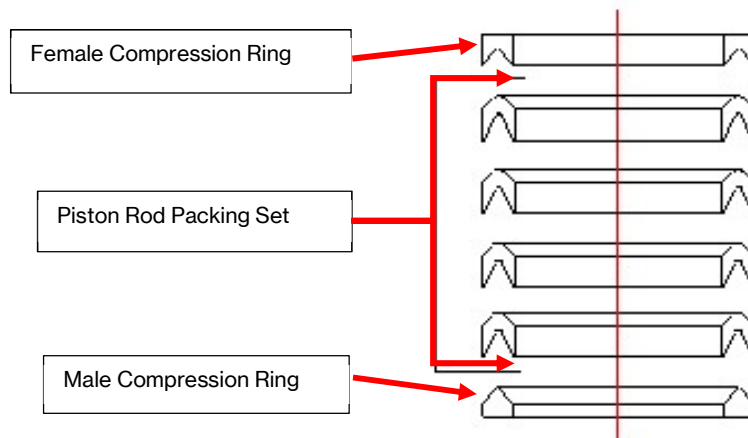

16. Push the packing set, spring, and retainer onto the piston rod and up into the packing cavity.

## Install Piston Body

17. Insert the piston ball spring into the piston rod, making sure the spring goes onto the end of the dowel pin located on the bottom of the piston rod.
18. Take the piston body assembly (consisting of the ball, compression ring, piston cups, spacer ring, backup ring, and piston body) and thread it into the end of the piston rod.

---

**Note**     ***If the piston body is screwed tightly against the piston rod but the packing cups still rotate easily, the top of the compression ring is not aligned correctly. Disassemble the piston body and reinstall.***

## Install Foot Valve

19. Insert the cylinder and foot valve body onto the piston rod.
20. Coat the threads of the two hex screws with a thin layer of grease, then gently hand tighten the screws to secure the foot valve collar, foot valve body, and cylinder to the pump's center section; do not completely tighten at this time.
21. Check the orientation of the inlet elbow and reinstall.
22. When the foot valve body is oriented correctly, tighten the hex screws in an alternating pattern to 13 ft/lbs.

**Note**     ***Do not overtighten the hex screws. Damage to the center section will occur.***

## Install Valves to Shift Block

23. Install the nipple and reducer onto the operator valve.
24. Install the mufflers onto the operator valve.
25. Screw the two tube fittings into the operator valve body.
26. Hold the guard and operator valve up to the actuator body and attach with machine screws.
27. Attach the urethane tube to the operator valve.
28. Install the actuator into the actuator body and install the nut.
29. Thread the elbow into the end of the actuator.
30. Install the urethane tube onto the actuator.
31. Install the urethane tube onto the elbow.
32. Repeat steps [28](#) - [31](#) for the other end if necessary.

## Install Shift Block

33. Place the new O-ring on top of the shift block assembly and lubricate with red grease.
34. Make sure the socket cap screw is in the center stroke position.

**Note**     ***If the screw is not in the center stroke position when you attempt to connect the shift valve assembly to the pump you will damage the equipment.***

35. Coat the three hex screws thinly with red grease, then hold the shift block assembly against the pump's center section and slightly finger-tighten each screw.
36. Use one had to press the shift block assembly upward while tightening the hex screws in an alternating pattern.

---

**Note**     ***Tightening the hex screws secures the O-ring on top of the shift block assembly against the underside of the cylinder head. If the O-ring is not positioned properly, the pump will lose air pressure during operation.***

37. Install the air tube between the top of the pump and the shift block.
38. Connect the air hose and the clear tube to the shift block assembly.
39. Test the operator valve to ensure there is proper air flow intake and output.

## Reinstall Pro Pump

40. Install the air tube between the shift block and the top of the pump.
41. Remove the pump from the vise and install on the unit with hex cap screws.
42. Reconnect all hoses to the pump.
43. Increase the pump pressure.
44. Open the gun over an appropriate container and make sure the pump operates.

## Set Packing Set

45. Prime the pump fluid section.
46. Close the gun head.
47. **Slowly** increase pump pressure to 60 psi.
48. Keep the pump stalled for 5 to 15 minutes to allow the packing to set.
49. Decrease the pump pressure to the desired operating pressure.
50. Connect, prime, and pressurize the catalyst pump for operation.

## Maintaining Pump

Performing proper maintenance at the recommended intervals maximized your equipment's productivity and efficiency. Follow the maintenance schedule outlined in this manual. This schedule is based on a one-shift, 5-day work week using standard general purpose (GP) resin. An idle unit with resin left in it requires more frequent parts replacement. This manual details the maintenance required on the Pro Pump. Other system components will require maintenance as well. For full system maintenance, refer to your system's operations manual.

## Daily Maintenance

1. Drain the air filter by holding a container under the filter and turning the valve at the bottom.
2. Check the oil reservoir on the pump and add oil if needed.

## Weekly Maintenance

In addition to the daily procedure, once a week add the following steps:

3. Remove the accumulator and clean inside.



### **WARNING**

***Never attempt to remove, repair, or clean an accumulator until you have relieved pressure. If material is plugging the system, some parts may still contain fluids under high pressure. To prevent injury, hold a large rag or towel around the wrench and fitting when removing the fitting.***

4. Clean and inspect the filter screen.

**Note**      ***You will also need to clean the filter screen when changing material being pumped.***

5. If needed, clean and dry the silencers on the pump.
6. Check the pickup hose and wand for leaks or damage; replace as needed.
7. Check for packing leaks; tighten as needed.

## Bi-Annual Maintenance

Once every six months, perform the following additional maintenance steps:

8. Replace the accumulator O-rings while reassembling after cleaning.
9. Check the Pro Pump piston rod, cylinder head, piston, and trip sleeve for wear or damage and replace as needed.
10. Replace the pump O-rings, piston cups, and packing set.
11. Check the pump lower assembly piston rod and pump cylinder for wear or damage and replace as needed.
12. Replace the packing set, piston cups, and O-rings.

## Annual Maintenance

Once a year, rebuild the pump lower assembly.

## Troubleshooting

Troubleshooting		
Symptom	Possible Cause	Remedy
Low output on upstroke of Pro Pump	Piston cups, piston ball, or pump cylinder worn	Inspect, clean and replace components as needed
No fan, constant low output, or fast cure	Resin filter blocked	Disassemble and clean filter body and screen with solvent

<b>Troubleshooting</b>		
<b>Symptom</b>	<b>Possible Cause</b>	<b>Remedy</b>
No fan, constant low output, or fast cure	Resin hose plugged	Flush hose with solvent. If material is hard, replace hose
	Pickup wand assembly leaking	Tighten assembly fittings
	Resin filter clogged	Disassemble and clean the resin filter
	Screen of pickup wand blocked	Unscrew screen from hose and clean
Fan too narrow or wide	Resin filter clogged	Disassemble and clean the resin filter
Excessive misting or heavy pulsation	Resin accumulator plugged	Disassemble accumulator and clean
Pump jumps on upstroke	Piston ball worn or not seating properly	Replace piston ball and piston cups. Be sure to lubricate ball and cups thoroughly with red grease.
Pump dives on downstroke	Foot valve, spring retainer, or foot valve ball damaged or dirty	Clean or replace foot valve, spring retainer, and foot valve ball. Be sure to lubricate ball thoroughly with red grease.
	Pickup wand assembly not tight	Tighten or seal joints of pickup wand
Low output on upstroke	Piston cups, piston ball, or pump cylinder worn	Inspect the piston cups, piston ball, and pump cylinder and clean or replace components as needed
Pump does not run	Silencers on valve block plugged	Turn off air to pump and unscrew silencers, clean and reinstall.
	Actuator valve or socket cap screw at shift block broken	Replace the broken cartridge valve or socket cap screw
	Pump or hose blocked	Disassemble and clean pump. Replace any worn parts or hose as needed
	Air not connected	Check that air hose is connected at air manifold and regulator is at 20 psi or more
	Pump not primed	Check all connections between pump and end of pick-up wand for leaks, then prime resin system
	Air restricted	Straighten any kinks in air hoses
Material in oil reservoir	Packing worn	Replace packing set in lower part of pump
	Piston rod worn or scored	Replace piston rod
No gelcoat delivery on downstroke	Foot valve, spring retainer, or foot valve ball damaged or dirty	Clean or replace parts as needed. Be sure to lubricate ball thoroughly with red grease.

## Parts Drawings

The following illustrations are included for your reference when servicing the equipment and ordering parts. Make sure you refer to the drawing specific to the model you are working on to ensure you order the correct replacement parts.

<b>Parts Drawings</b>	
<b>Part Number</b>	<b>Description</b>
VPRO-45110	11:1 Pump Assembly
VPRO-45110-FP	11:1 Pump Assembly
VPRO-45110-IM	11:1 Pump Assembly – Internal Mix
VPRO-45110-QS	11:1 Pump Assembly – Quick Shot
VPRO-25400	4:1 Pump Assembly
VPRO-25400-FIT	4:1 Pump Assembly – FIT
VPRO-2000	Shift Block Assembly
VPRO-45110-SK	Seal Kit
VPRO-45110-FP-SK	Seal Kit – Flush Pump
VPRO-25400-SK	Seal Kit – 4:1 Pump Assembly
VPRO-45220	22:1 Pump Assembly
VPRO-45220-IM	22:1 Pump Assembly
VPRO-45220-MC	22:1 Pump Assembly – Multi-Color
VPRO-45220-NPR	22:1 Pump Assembly – Pro Rider
VPRO-25700	7:1 Pump Assembly
VPRO-45220-SK	Seal Kit – 22:1 Pump Assembly
VPRO-25700-SK	Seal Kit – 7:1 Pump Assembly

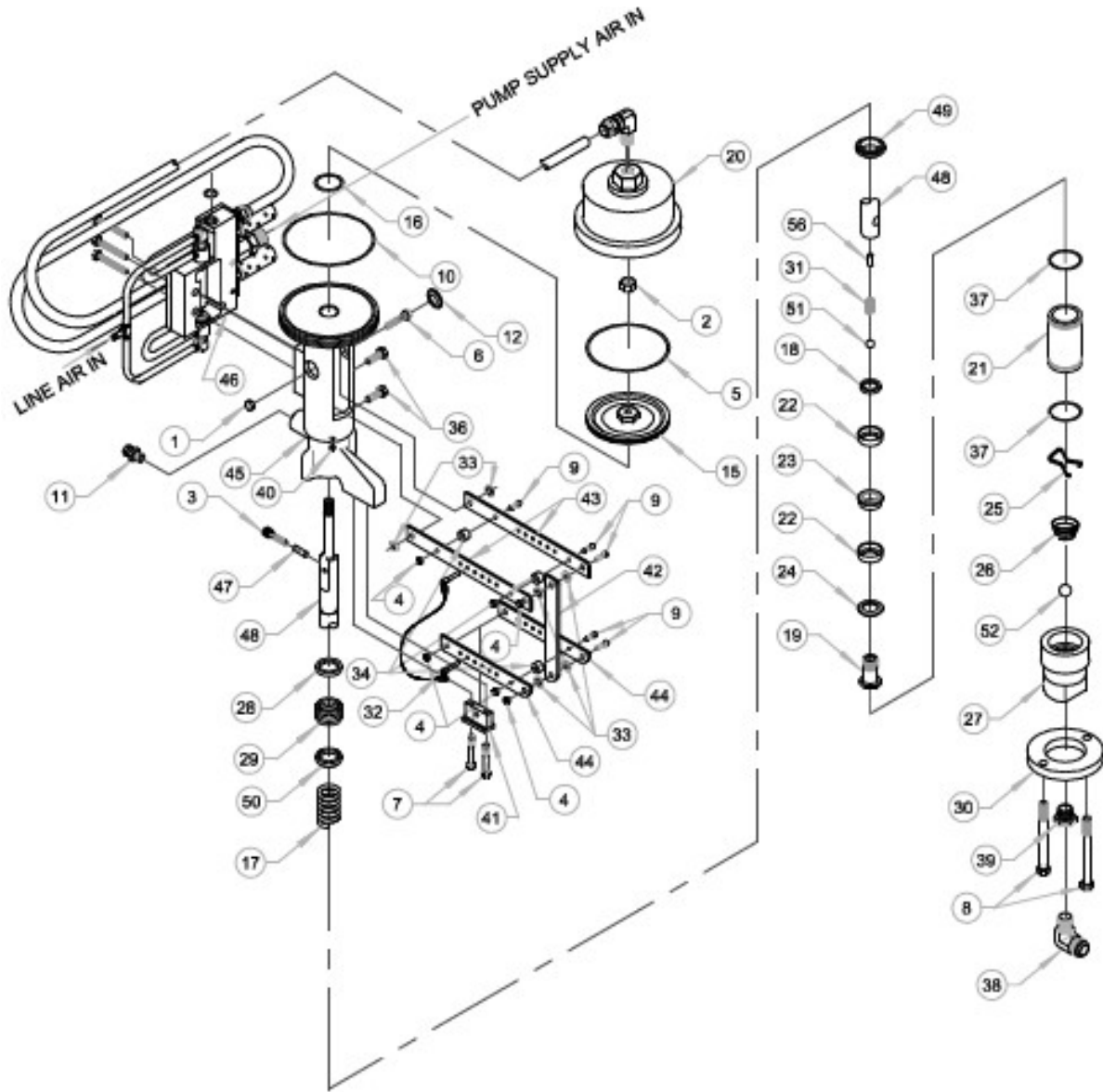

## MAGNUM VENUS PLASTECH

ASSY - 11 : 1 PRO PUMP

VPRO-45110

REV. D - ITEM 10 WAS 04305-1, UPDATED NUMBERS TO ALPHA-NUMERIC 03/08/06 BT2  
 REV. E - REMOVED NOTE FOR EXTERNAL MIX ONLY 03/29/06 JEM  
 REV. F - REMOVED ITEM 218 15988-3 FROM OPTIONAL PARTS, NO LONGER AVAILABLE 07/26/10 BT2

## ASSY - 11 : 1 PRO PUMP VPRO-45110

## PARTS LIST

ITEM	PART NO.	QTY	DESCRIPTION
1	F-LN-04C	1	LOCK NUT
2	F-JN-07C	1	HEX NUT
3	F-CS-04C-24-SS	1	SOCKET HEAD CAP SCREW
4	F-LN-04F	6	LOCK NUT
5	O-B-242	1	O-RING
6	F-HB-04C-24	1	HEX BOLT
7	F-HB-05C-32	2	HEX BOLT
8	F-HB-06C-76-GR5	2	HEX BOLT
9	02966	6	AIRCRAFT BOLT
10	O-S-157	1	O-RING
11	PF-SW-08	1	SWIVEL FITTING
12	15515	1	PLUG
15	15888-1	1	AIR MOTOR PISTON
16	O-B-112	1	O-RING
17	04305-1	1	SPRING
18	15936-1	1	COMPRESSION RING
19	15939-1	1	PISTON BODY
20	15983-1	1	CYLINDER HEAD
21	15986-1	1	CYLINDER
22	VLS-4615	2	PISTON CUP
23	VLS-4616	1	PISTON CUP SPACER
24	VLS-4617	1	PISTON CUP BACKUP
25	VLS-4620	1	BALL STOP
26	VLS-4621	1	FOOT VALVE SPRING
27	VLS-4602	1	FOOT VALVE BODY
28	VLS-4604	1	FEMALE COMPRESSION RING
29	VLS-4605	1	PISTON ROD PACKING SPA
30	VLS-2424	1	FOOT VALVE COLLAR
31	VLS-2414	1	PISTON BALL SPRING
32	52106-3	1	QUICK PIN CABLE ASSY.
33	VPRO-1008	6	SLAVE ARM BUSHING
34	VPRO-1005	3	SLAVE ARM SPACER
36	F-HB-05C-12	2	HEX BOLT
37	O-V-137-90	2	O-RING
38	PF-ME-12-12J	1	MALE ELBOW
39	PF-RB-16-12	1	REDUCER BUSHING
40	7701-4-5	1	PLASTIC PLUG
41	VPRO-1007	1	MOUNT BLOCK
42	VPRO-1003-01	1	LINK BAR
43	VPRO-1001	2	UPPER SLAVE ARM
44	VPRO-1002	2	LOWER SLAVE ARM
45	85729-3	1	CENTER SECTION ASSY.
46	VPRO-2000	1	SHIFT BLOCK ASSY.
47	85806-1	1	TRIP SLEEVE
48	85810-1	1	PISTON ROD
49	86800-1	1	SPRING RETAINER
50	87060-1	1	MALE COMPRESSION RING
51	ALS-1018	1	CHROME BALL
52	VLS-4622	1	CHROME BALL
53	95033-EN	1	PUMP PRIME CAUTION LABEL (NOT SHOWN)
54	95081-3	1	SLAVE ARM DECAL (NOT SHOWN)
55	95084-EN	1	AIR SHUT OFF CAUTION LABEL (NOT SHOWN)

## REPAIR KITS

PART NO.	DESCRIPTION
VPRO-45110-SK	SEAL KIT

## OPTIONAL PARTS AND ASSEMBLIES

ITEM	PART NO.	QTY	DESCRIPTION
23B	3101-13-2	1	HARDENED PISTON CUP SPACER
24B	3101-14-2	1	HARDENED PISTON CUP BACKUP
56	VLS-2425	1	BALL STOP PIN

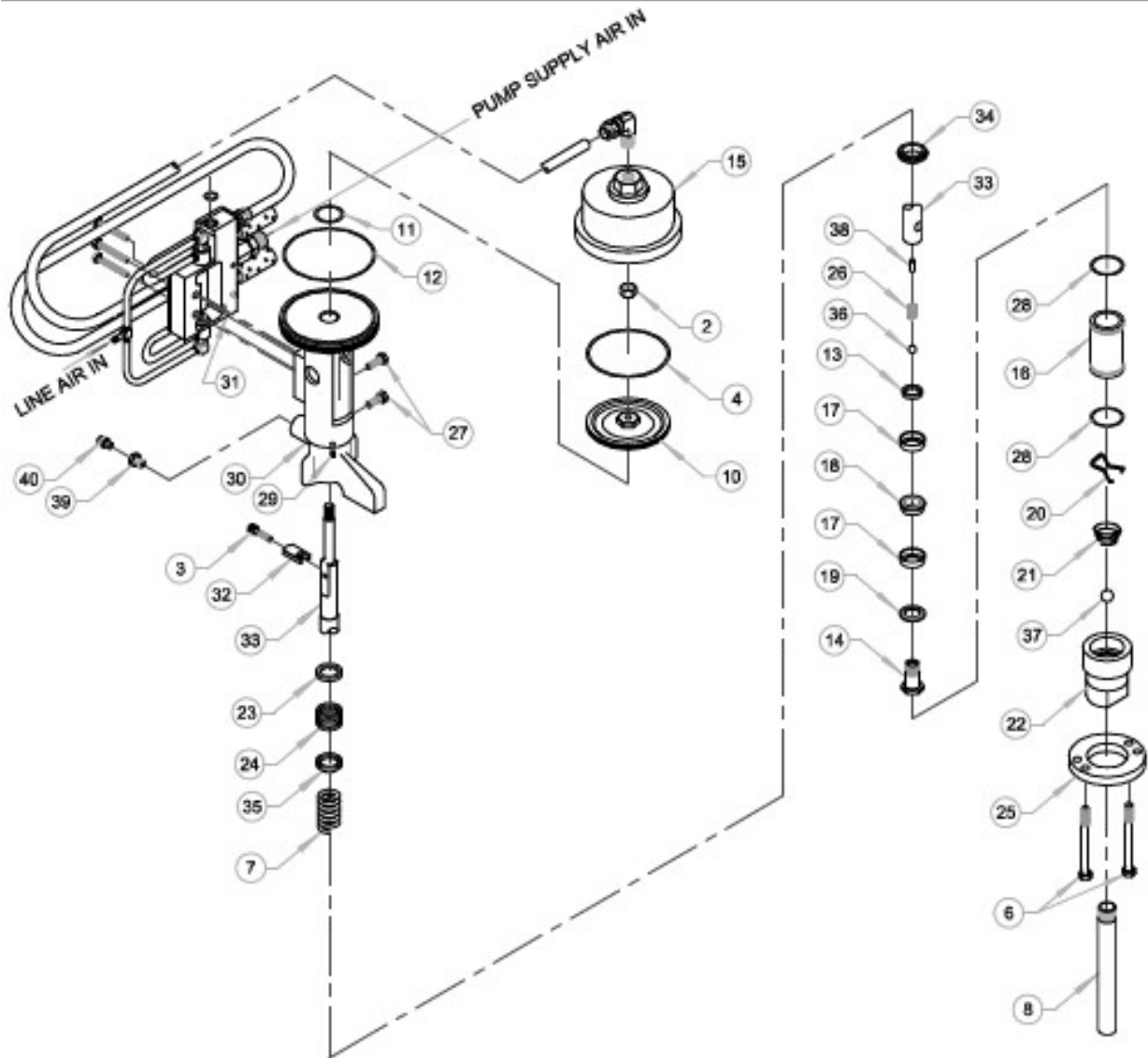

## MAGNUM VENUS PLASTECH

11 : 1 FLUSH PUMP

VPRO-45110-FP

REV. 11-02-06 BT2  
 REV. A - CORRECTED ITEMS 2, 6, 7, 14, 30, 35, AND 37, DELETED 1, 5, AND 9 03/08/06 BT2  
 REV. B - ITEM 24 WAS VLS-4606 09/23/11 BT2

## 11 : 1 PRO PUMP FOR FLUSH PUMP VPRO-45110-FP PARTS LIST

ITEM	PART NO.	QTY	DESCRIPTION
2	F-JN-07C	1	HEX NUT
3	F-CS-04C-24-SS	1	SOCKET HEAD CAP SCREW
* 4	O-B-242	1	O-RING
6	F-HB-06C-76-GR5	2	HEX BOLT
7	04305-1	1	LOWER PACKING SPRING
8	NPR-1004	1	SUCTION TUBE
10	15888-1	1	AJR MOTOR PISTON
* 11	O-B-112	1	O-RING
* 12	O-B-157	1	O-RING
13	15936-1	1	COMPRESSION RING
14	15939-1	1	PISTON BODY
15	15983-1	1	CYLINDER HEAD
16	15986-1	1	CYLINDER
* 17	VLS-4615	2	PISTON CUP
18	VLS-4618	1	PISTON CUP SPACER
19	VLS-4617	1	PISTON CUP BACKUP
20	VLS-4620	1	BALL STOP
21	VLS-4621	1	FOOT VALVE SPRING
22	VLS-4602	1	FOOT VALVE BODY
23	VLS-4604	1	FEMALE COMPRESSION RING
* 24	VLS-4605-2U2G	1	PISTON ROD PACKING SPA
25	VLS-2424	1	FOOT VALVE COLLAR
26	VLS-2414	1	PISTON BALL SPRING
27	F-HB-05C-12	2	HEX CAP SCREW
* 28	O-E-137	2	O-RING
29	7701-4-5	1	PLASTIC PLUG
30	85729-3	1	CENTER SECTION ASSY
31	VPRO-2000	1	SHIFT BLOCK ASSY
32	VPRO-2005	1	ROTATIONAL STOP
33	85810-1	1	PISTON ROD
34	86800-1	1	SPRING RETAINER
35	87060-1	1	MALE COMPRESSION RING
36	ALS-1018	1	7/8" CHROME BALL
37	VLS-4622	1	1-1/4" CHROME BALL
39	PF-RB-06-04	1	REDUCER BUSHING
40	PF-HN-04-04S	1	HEX NIPPLE
	95084-EN	1	AIR SHUT OFF CAUTION LABEL (NOT SHOWN)

## REPAIR KITS

PART NO.	DESCRIPTION
* VPRO-45110-FP-SK	SEAL KIT

## OPTIONAL PARTS AND ASSEMBLIES

ITEM	PART NO.	QTY	DESCRIPTION
38	VLS-2425	1	BALL STOP PIN

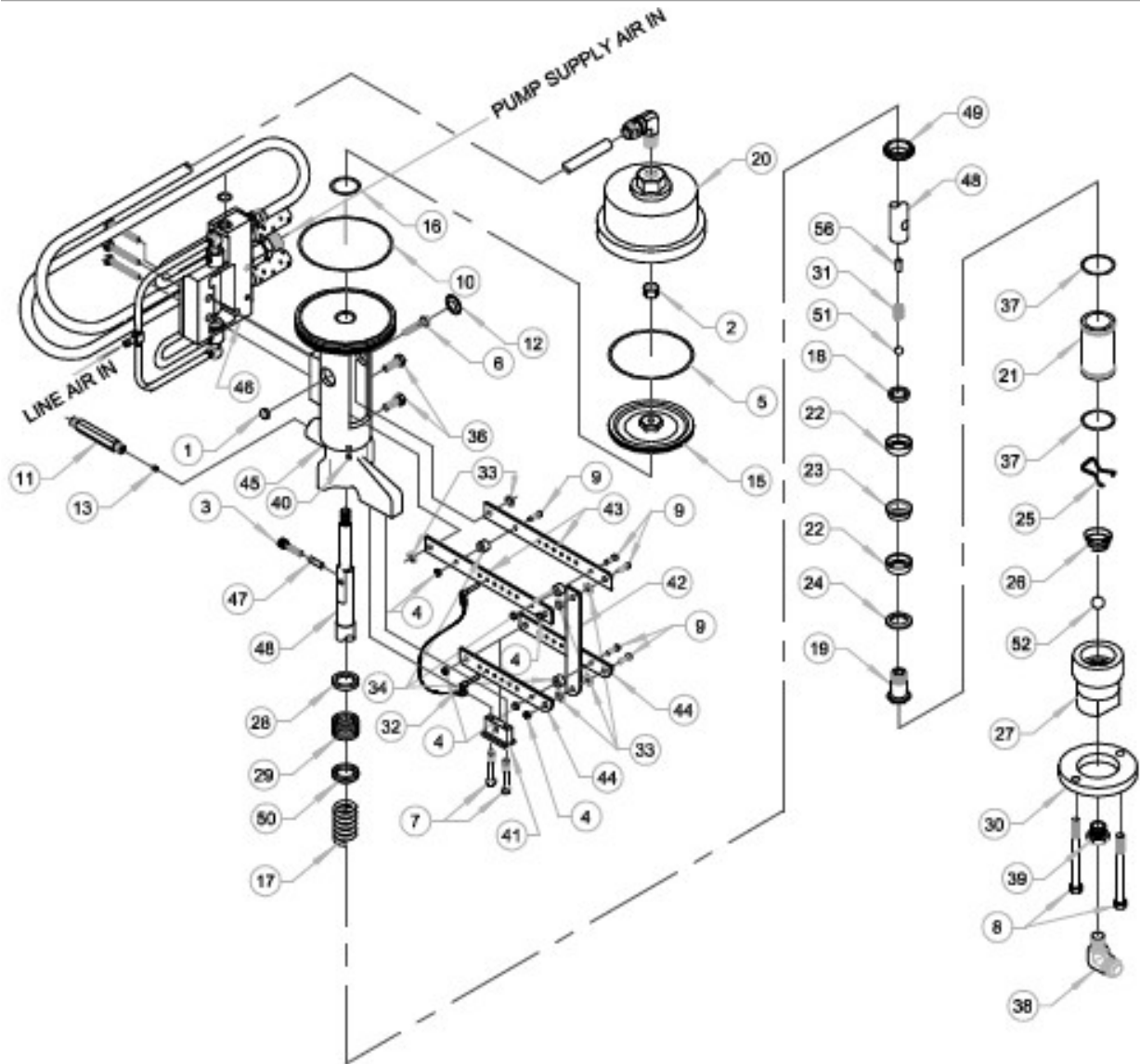

# MAGNUM VENUS PLASTECH

ASSY - 11 : 1 PRO PUMP

VPRO-45110-IM

REV. - 12/12/08 JEM  
 REV. A - REMOVED ITEM 21B 15905-3 FROM OPTIONAL PARTS - NO LONGER AVAILABLE 07/26/10 BT2

**ASSY - 11 : 1 PRO PUMP VPRO-45110-IM  
PARTS LIST**

ITEM	PART NO.	QTY	DESCRIPTION
1	F-LN-04C	1	LOCK NUT
2	F-JN-07C	1	HEX NUT
3	F-CS-04C-24-SS	1	SOCKET HEAD CAP SCREW
4	F-LN-04F	6	LOCK NUT
5	O-B-242	1	O-RING
6	F-HB-04C-24	1	HEX BOLT
7	F-HB-05C-32	2	HEX BOLT
8	F-HB-06C-76-GR5	2	HEX BOLT
9	02966	6	AIRCRAFT BOLT
10	O-B-157	1	O-RING
11	85712-1	1	FLOW CONTROL BODY
12	15515	1	PLUG
13	85713-1	1	FLOW CONTROL ORIFICE
15	15888-1	1	AIR MOTOR PISTON
16	O-B-112	1	O-RING
17	04305-1	1	SPRING
18	15936-1	1	COMPRESSION RING
19	15939-1	1	PISTON BODY
20	15983-1	1	CYLINDER HEAD
21	15986-1	1	CYLINDER
22	VLS-4615	2	PISTON CUP
23	VLS-4616	1	PISTON CUP SPACER
24	VLS-4617	1	PISTON CUP BACKUP
25	VLS-4620	1	BALL STOP
26	VLS-4621	1	FOOT VALVE SPRING
27	VLS-4602	1	FOOT VALVE BODY
28	VLS-4604	1	FEMALE COMPRESSION RING
29	VLS-4605	1	PISTON ROD PACKING SPA
30	VLS-2424	1	FOOT VALVE COLLAR
31	VLS-2414	1	PISTON BALL SPRING
32	52108-3	1	QUICK PIN CABLE ASSY.
33	VPRO-1006	6	SLAVE ARM BUSHING
34	VPRO-1005	3	SLAVE ARM SPACER
38	F-HB-05C-12	2	HEX BOLT
37	O-V-137-90	2	O-RING
38	PF-ME-12-12J	1	MALE ELBOW
39	PF-RB-16-12	1	REDUCER BUSHING
40	7701-4-5	1	PLASTIC PLUG
41	VPRO-1007	1	MOUNT BLOCK
42	VPRO-1003-01	1	LINK BAR
43	VPRO-1001	2	UPPER SLAVE ARM
44	VPRO-1002	2	LOWER SLAVE ARM
45	85729-3	1	CENTER SECTION ASSY.
46	VPRO-2000	1	SHIFT BLOCK ASSY.
47	85806-1	1	TRIP SLEEVE
48	85810-1	1	PISTON ROD
49	86800-1	1	SPRING RETAINER
50	87060-1	1	MALE COMPRESSION RING
51	ALS-1018	1	CHROME BALL
52	VLS-4622	1	CHROME BALL
53	95033-EN	1	PUMP PRIME CAUTION LABEL (NOT SHOWN)
54	95081-3	1	SLAVE ARM DECAL (NOT SHOWN)
55	95084-EN	1	AIR SHUT OFF CAUTION LABEL (NOT SHOWN)

**REPAIR KITS**

PART NO.	DESCRIPTION
VPRO-45110-SK	SEAL KIT

**OPTIONAL PARTS AND ASSEMBLIES**

ITEM	PART NO.	QTY	DESCRIPTION
23B	3101-13-2	1	HARDENED PISTON CUP SPACER
24B	3101-14-2	1	HARDENED PISTON CUP BACKUP
56	VLS-2425	1	BALL STOP PIN

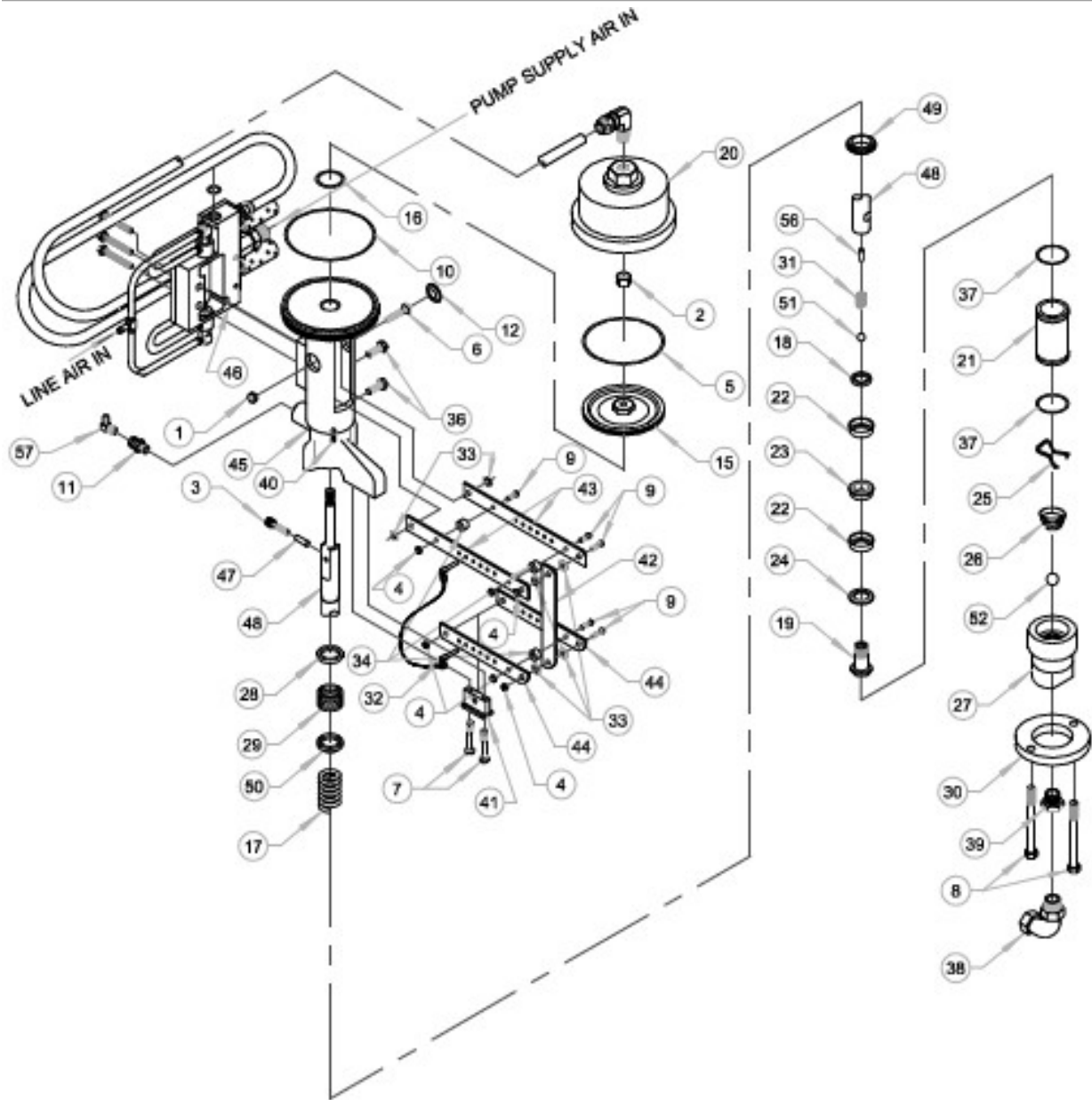

# MAGNUM VENUS PLASTECH

ASSY - 11 : 1 PRO PUMP

VPRO-45110-QS

REV. - 03/16/09 BT2  
REV. A - REMOVED ITEM 21B FROM OPTIONAL PARTS, NO LONGER AVAILABLE 07/26/10 BT2

## ASSY - 11 : 1 PRO PUMP VPRO-45110-QS

## PARTS LIST

ITEM	PART NO.	QTY	DESCRIPTION
1	F-LN-04C	1	LOCK NUT
2	F-JN-07C	1	HEX NUT
3	F-CS-04C-24-SS	1	SOCKET HEAD CAP SCREW
4	F-LN-04F	6	LOCK NUT
5	O-B-242	1	O-RING
6	F-HB-04C-24	1	HEX BOLT
7	F-HB-05C-32	2	HEX BOLT
8	F-HB-06C-76-GR5	2	HEX BOLT
9	02968	6	AIRCRAFT BOLT
10	O-B-157	1	O-RING
11	PF-SW-06	1	SWIVEL FITTING
12	15515	1	PLUG
15	15888-1	1	AIR MOTOR PISTON
16	O-B-112	1	O-RING
17	04305-1	1	SPRING
18	15938-1	1	COMPRESSION RING
19	15939-1	1	PISTON BODY
20	15883-1	1	CYLINDER HEAD
21	15986-1	1	CYLINDER
22	VLS-4615	2	PISTON CUP
23	VLS-4616	1	PISTON CUP SPACER
24	VLS-4617	1	PISTON CUP BACKUP
25	VLS-4620	1	BALL STOP
26	VLS-4621	1	FOOT VALVE SPRING
27	VLS-4602	1	FOOT VALVE BODY
28	VLS-4804	1	FEMALE COMPRESSION RING
29	VLS-4805	1	PISTON ROD PACKING SPA
30	VLS-2424	1	FOOT VALVE COLLAR
31	VLS-2414	1	PISTON BALL SPRING
32	52106-3	1	QUICK PIN CABLE ASSY.
33	VPRO-1006	6	SLAVE ARM BUSHING
34	VPRO-1005	3	SLAVE ARM SPACER
36	F-HB-05C-12	2	HEX BOLT
37	O-V-137-90	2	O-RING
38	PF-SE-SW-12	1	MALE ELBOW
39	PF-RB-16-12	1	REDUCER BUSHING
40	7701-4-5	1	PLASTIC PLUG
41	VPRO-1007	1	MOUNT BLOCK
42	VPRO-1003-01	1	LINK BAR
43	VPRO-1001	2	UPPER SLAVE ARM
44	VPRO-1002	2	LOWER SLAVE ARM
45	85729-3	1	CENTER SECTION ASSY.
46	VPRO-2000	1	SHIFT BLOCK ASSY.
47	85806-1	1	TRIP SLEEVE
48	85810-1	1	PISTON ROD
49	86800-1	1	SPRING RETAINER
50	87060-1	1	MALE COMPRESSION RING
51	ALS-1018	1	CHROME BALL
52	VLS-4622	1	CHROME BALL
53	95033-EN	1	PUMP PRIME CAUTION LABEL (NOT SHOWN)
54	95081-3	1	SLAVE ARM DECAL (NOT SHOWN)
55	95084-EN	1	AIR SHUT OFF CAUTION LABEL (NOT SHOWN)
57	PF-ME-06-04	1	MALE ELBOW

## REPAIR KITS

PART NO.	DESCRIPTION
VPRO-45110-SK	SEAL KIT

## OPTIONAL PARTS AND ASSEMBLIES

ITEM	PART NO.	QTY	DESCRIPTION
238	3101-13-2	1	HARDENED PISTON CUP SPACER
248	3101-14-2	1	HARDENED PISTON CUP BACKUP
56	VLS-2425	1	BALL STOP PIN (PART OF 48)

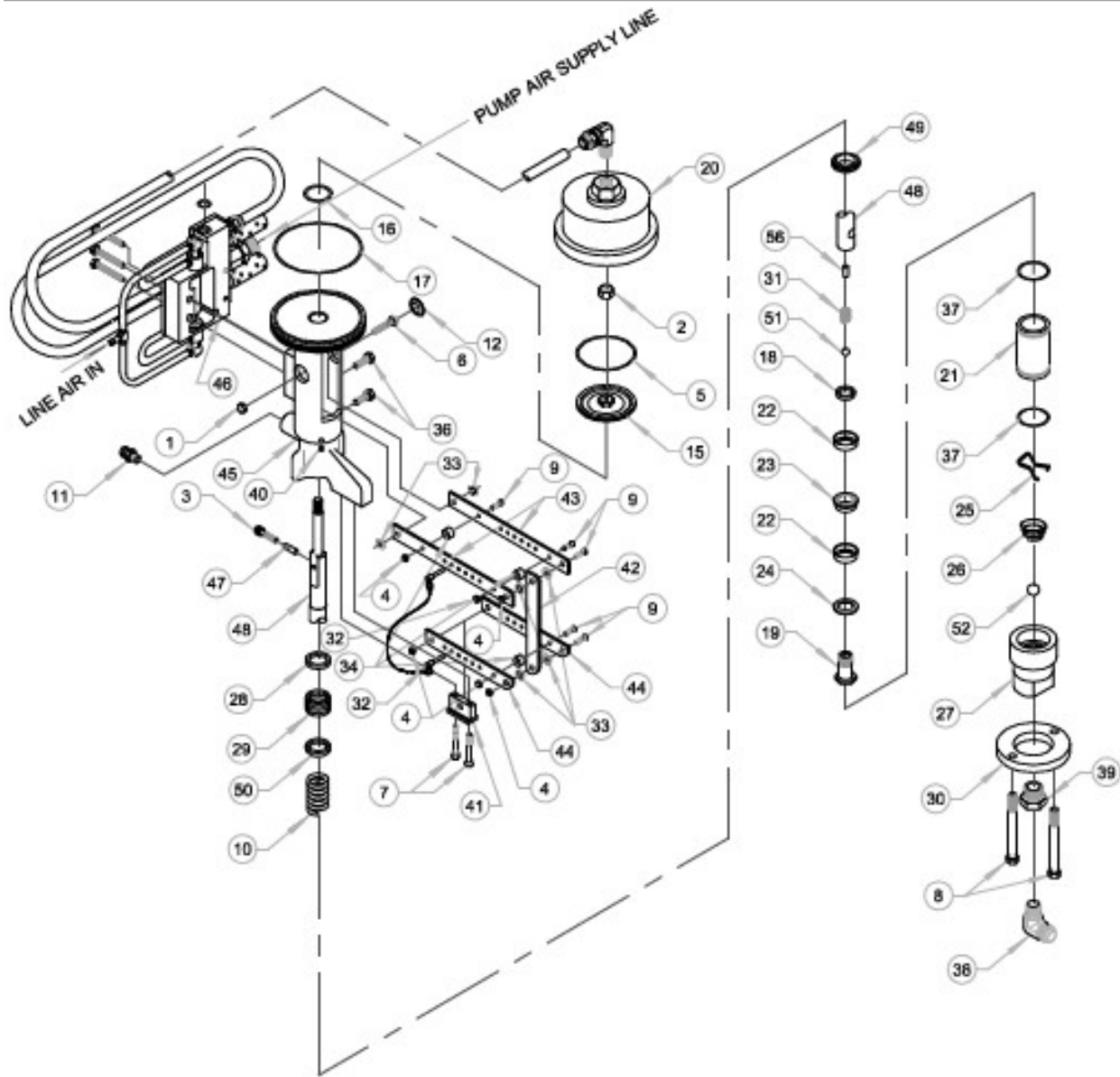

## MAGNUM VENUS PLASTECH

ASSY - 4 : 1 PRO PUMP

VPRO-25400

REV. A - VPRO-1007 WAS VPRO-1004, VPRO-1005 QTY OF 3 WAS 4 07/22/02  
 REV. B - VPRO-1003-01 WAS VPRO-1003  
 REV. C - REPLACED 85774-1 WITH VPRO-2000 7/18/03 JEM  
 REV. D - UPDATED NUMBERS TO ALPHA-NUMERIC, DELETED ITEM 218 15986-3, NO LONGER AVAILABLE 12/02/10 BTZ

## ASSY - 4 : 1 PRO PUMP VPRO-25400

## PARTS LIST

ITEM	PART NO.	QTY	DESCRIPTION
1	F-LN-04C	1	LOCK NUT
2	F-HN-07C	1	HEX NUT
3	F-CS-04C-24	1	SOCKET HEAD CAP SCREW
4	F-LN-04F	6	LOCK NUT
5	O-B-228	1	O-RING
6	F-HB-04C-24	1	HEX BOLT
7	F-HB-05C-32	2	HEX BOLT
8	F-HB-06C-76-GR5	2	HEX BOLT
9	02966	6	AIRCRAFT BOLT
10	04305-1	1	LOWER PACKING SPRING
11	PF-SW-06	1	SWIVEL FITTING
12	15515	1	PLUG
15	VPRO-25402	1	AIR MOTOR PISTON
16	O-B-112	1	O-RING
17	O-B-157	1	O-RING
18	15936-1	1	COMPRESSION RING
19	15939-1	1	PISTON BODY
20	VPRO-25401	1	CYLINDER HEAD
21	15988-1	1	CYLINDER
22	VLS-4615	2	PISTON CUP
23	VLS-4616	1	PISTON CUP SPACER
24	VLS-4617	1	PISTON CUP BACKUP
25	VLS-4620	1	BALL STOP
26	VLS-4621	1	FOOT VALVE SPRING
27	VLS-4602	1	FOOT VALVE BODY
28	VLS-4604	1	FEMALE COMPRESSION RING
29	VLS-4606	1	PISTON ROD PACKING SPA
30	VLS-2424	1	FOOT VALVE COLLAR
31	VLS-2414	1	PISTON BALL SPRING
32	52106-3	1	QUICK PIN CABLE ASSY
33	VPRO-1006	6	SLAVE ARM BUSHING
34	VPRO-1005	3	SLAVE ARM SPACER
36	F-HB-05C-12	2	HEX BOLT
37	O-V-137-90	2	O-RING
38	PF-ME-12-12J	1	MALE ELBOW
39	PF-RB-16-12	1	REDUCER BUSHING
40	7701-4-5	1	PLASTIC PLUG
41	VPRO-1007	1	MOUNT BLOCK
42	VPRO-1003-01	1	LINK BAR
43	VPRO-1001	2	UPPER SLAVE ARM
44	VPRO-1002	2	LOWER SLAVE ARM
45	85729-3	1	CENTER SECTION ASSY
46	VPRO-2000	1	SHIFT BLOCK ASSY
47	85806-1	1	TRIP SLEEVE
48	85810-1	1	PISTON ROD
49	86800-1	1	SPRING RETAINER
50	87060-1	1	MALE COMPRESSION RING
51	ALS-1018	1	7/8" CHROME BALL
52	VLS-4622	1	1-1/4" CHROME BALL
53	95033-EN	1	PUMP PRIME CAUTION LABEL (NOT SHOWN)
54	95081-3	1	SLAVE ARM DECAL (NOT SHOWN)
55	95084-EN	1	AIR SHUT OFF CAUTION LABEL (NOT SHOWN)

## REPAIR KITS

PART NO.	DESCRIPTION
VPRO-25400-SK	SEAL KIT

## OPTIONAL PARTS AND ASSEMBLIES

ITEM	PART NO.	QTY	DESCRIPTION
23B	3101-13-2	1	HARDENED PISTON CUP SPACER
24B	3101-14-2	1	HARDENED PISTON CUP BACKUP
56	VLS-2425	1	BALL STOP PIN

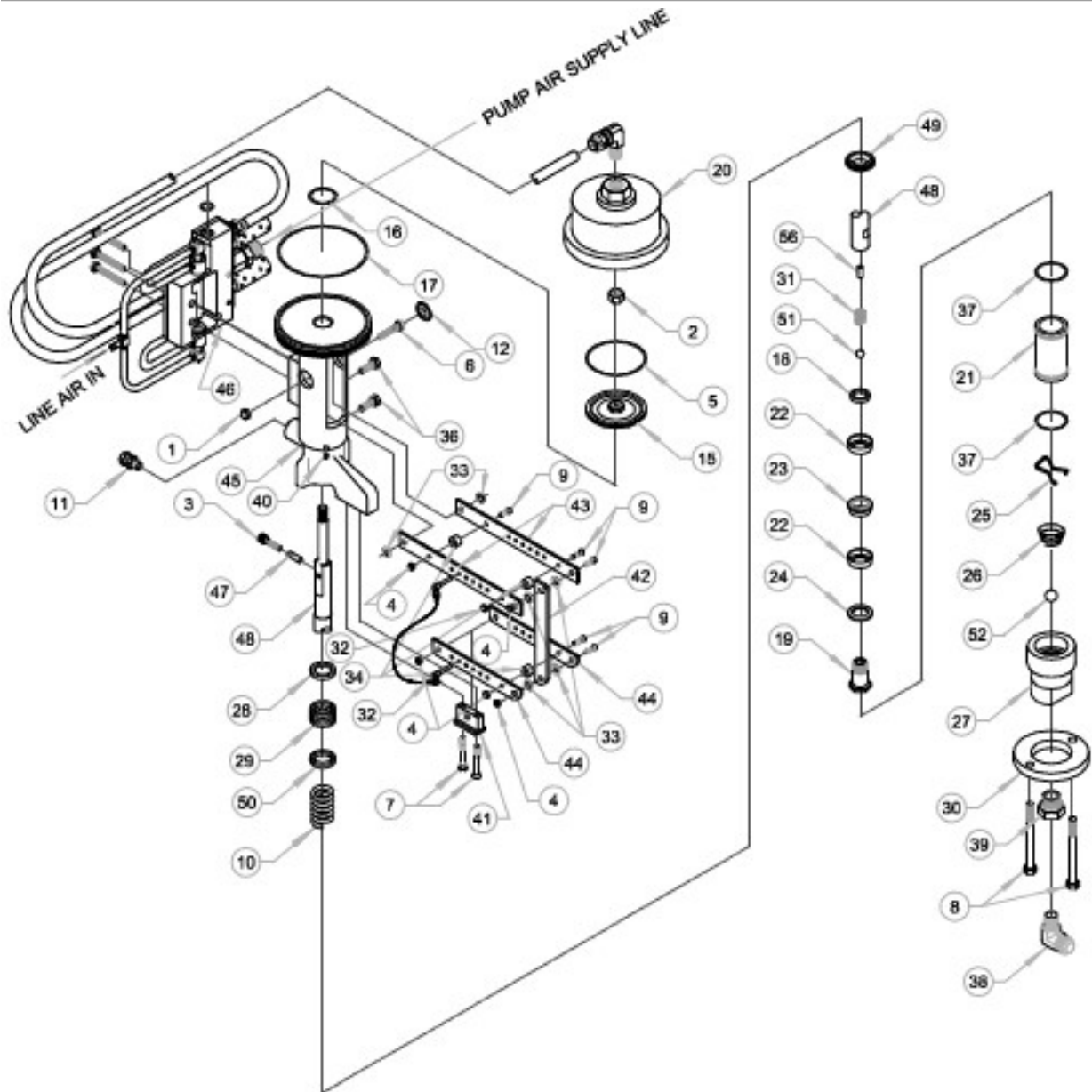

## MAGNUM VENUS PLASTECH

ASSY - 4 : 1 FIT PRO PUMP

VPRO-25400-FIT

REV. - 7/22/03 JEM  
 REV. A - UPDATED NUMBERS TO ALPHA-NUMERIC, DELETED ITEM 21B 15906-3, NO LONGER AVAILABLE 12/02/10 BT2

## ASSY - 4 : 1 FIT PRO PUMP VPRO-25400-FIT

## PARTS LIST

ITEM	PART NO.	QTY	DESCRIPTION
1	F-LN-04C	1	LOCK NUT
2	F-HB-07C	1	HEX NUT
3	F-CS-04C-24	1	SOCKET HEAD CAP SCREW
4	F-LN-04F	6	LOCK NUT
5	O-B-228	1	O-RING
6	F-HB-04C-24	1	HEX BOLT
7	F-HB-05C-32	2	HEX CAP SCREW
8	F-BH-06C-78-GR5	2	HEX BOLT
9	02966	6	AIRCRAFT BOLT
10	04305-1	1	LOWER PACKING SPRING
11	PF-SW-06	1	SWIVEL FITTING
12	15515	1	PLUG
15	VPRO-25402	1	AIR MOTOR PISTON
16	O-B-112	1	O-RING
17	O-B-157	1	O-RING
18	15936-1	1	COMPRESSION RING
19	15939-1	1	PISTON BODY
20	VPRO-25401	1	CYLINDER HEAD
21	15986-1	1	CYLINDER
22	VLS-4615	2	PISTON CUP
23	VLS-4616	1	PISTON CUP SPACER
24	VLS-4617	1	PISTON CUP BACKUP
25	VLS-4620	1	BALL STOP
26	VLS-4621	1	FOOT VALVE SPRING
27	VLS-4602	1	FOOT VALVE BODY
28	VLS-4604	1	FEMALE COMPRESSION RING
29	VLS-4605	1	PISTON ROD PACKING SPA
30	VLS-2424	1	FOOT VALVE COLLAR
31	VLS-2414	1	PISTON BALL SPRING
32	52106-3	1	QUICK PIN CABLE ASSY
33	VPRO-1006	6	SLAVE ARM BUSHING
34	VPRO-1005	3	SLAVE ARM SPACER
38	F-HB-05C-12	2	HEX BOLT
37	O-V-137-90	2	O-RING
38	PF-ME-16J-12	1	MALE ELBOW
39	PF-RB-16-12	1	REDUCER BUSHING
40	7701-4-5	1	PLASTIC PLUG
41	VPRO-1007	1	MOUNT BLOCK
42	VPRO-1003-01	1	LINK BAR
43	VPRO-1001	2	UPPER SLAVE ARM
44	VPRO-1002	2	LOWER SLAVE ARM
45	85729-3	1	CENTER SECTION ASSY
46	VPRO-2000	1	SHIFT BLOCK ASSY
47	85808-1	1	TRIP SLEEVE
48	85810-1	1	PISTON ROD
49	86800-1	1	SPRING RETAINER
50	87060-1	1	MALE COMPRESSION RING
51	ALS-1018	1	7/8" CHROME BALL
52	VLS-4622	1	1-1/4" CHROME BALL
53	95033-EN	1	PUMP PRIME CAUTION LABEL (NOT SHOWN)
54	95081-3	1	SLAVE ARM DECAL (NOT SHOWN)
55	95084-EN	1	AIR SHUT OFF CAUTION LABEL (NOT SHOWN)

## REPAIR KITS

PART NO.	DESCRIPTION
VPRO-25400-SK	SEAL KIT

## OPTIONAL PARTS AND ASSEMBLIES

ITEM	PART NO.	QTY	DESCRIPTION
23B	3101-13-2	1	HARDENED PISTON CUP SPACER
24B	3101-14-2	1	HARDENED PISTON CUP BACKUP
56	7203-2-10	1	BALL STOP PIN

**VPRO-2000  
SHIFT BLOCK ASSEMBLY FOR  
VPRO-25400, VPRO-45110,  
AND VPRO-45220**

09-17-12 (BT2)

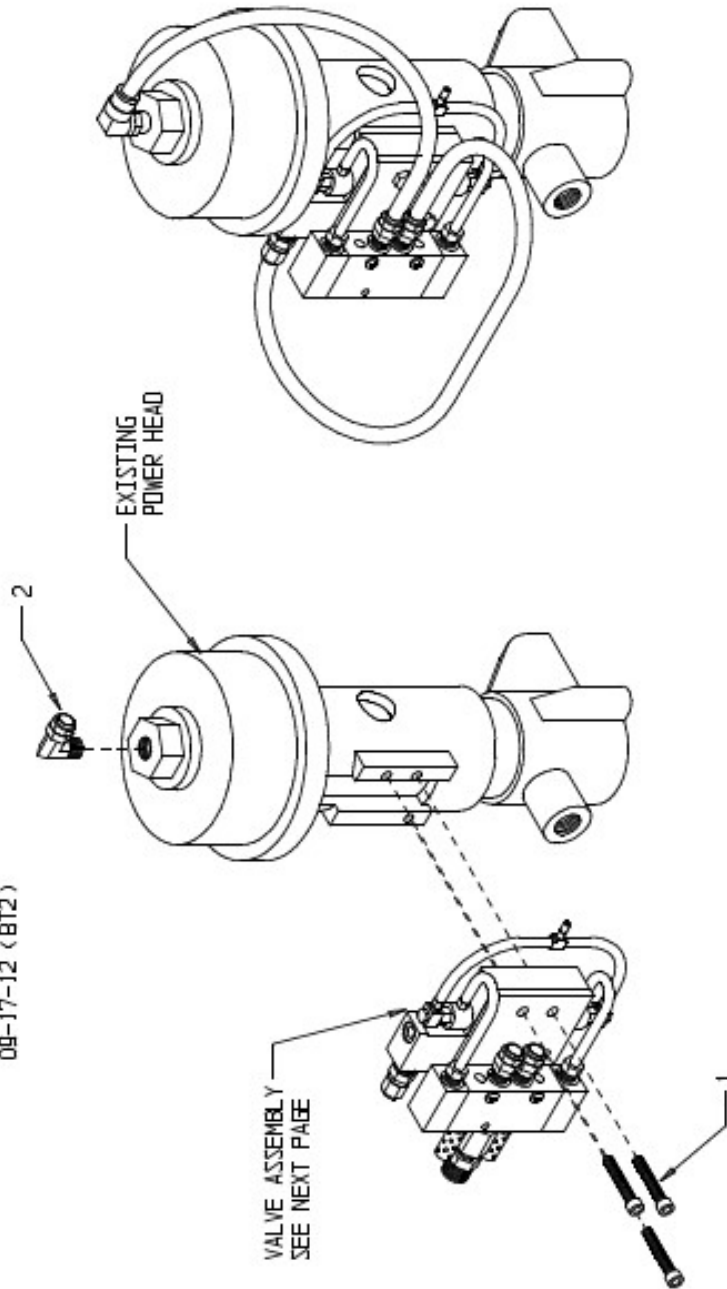

1. REMOVE EXISTING SHIFTING BLOCK ASSEMBLY, AND TUBE FITTING ON TOP OF POWER HEAD
2. ATTACH NEW SHIFTING BLOCK ASSEMBLY, USING THE 3 ) F-HB-04C-20 BOLTS PROVIDED
3. ATTACH ELBOW FITTING TO TOP OF POWER HEAD
4. ATTACH 3/8" TUBING TO FITTINGS AS ILLUSTRATED

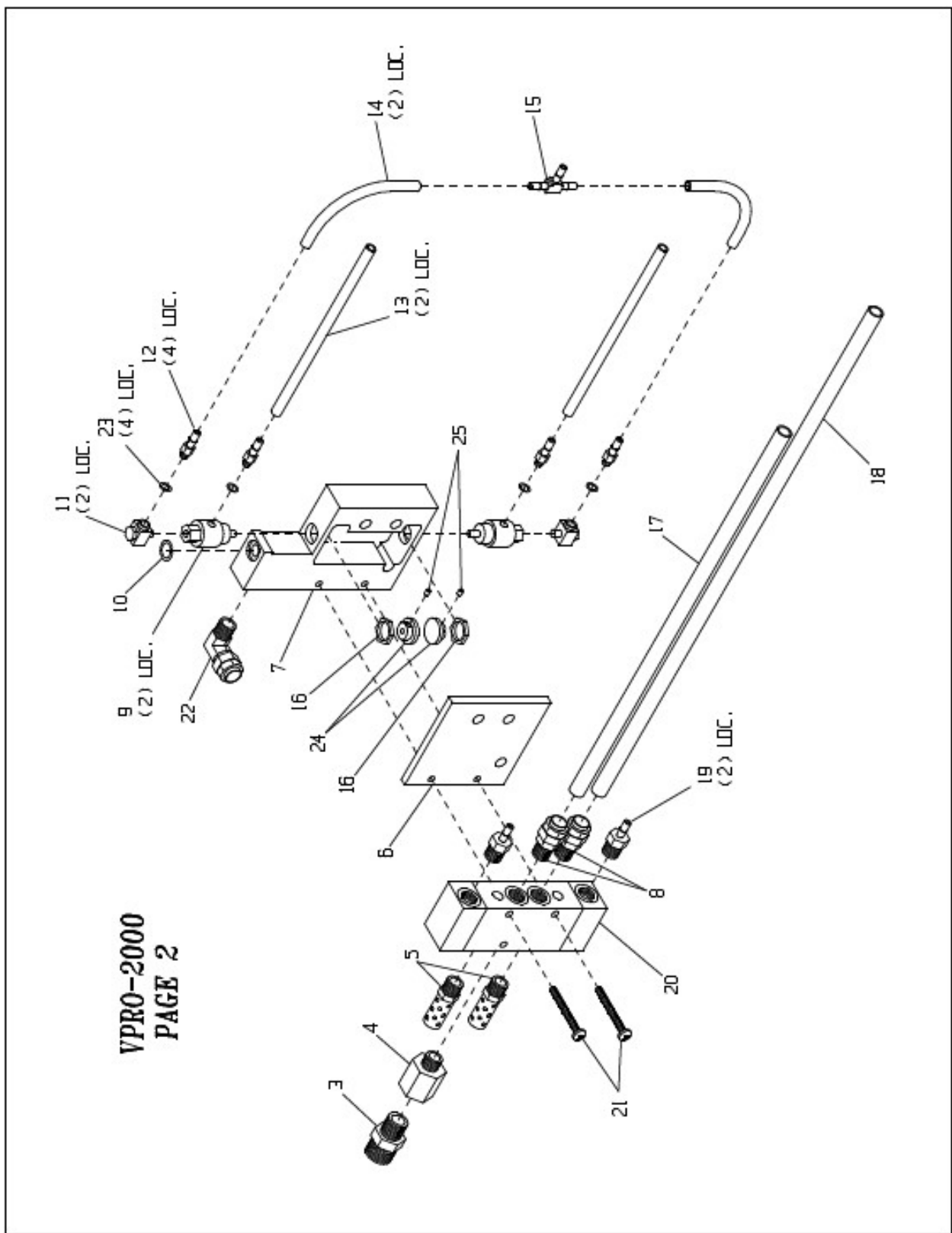

**VPRO-2000  
SHIFT BLOCK ASSEMBLY  
09-17-12  
PARTS KEY**

ITEM	PART #	DESCRIPTION	QTY
1	F-CS-04C-20	HEX BOLT	3
2	7701-6-17	ELBOW	1
3	PF-HN-06S-04	NIPPLE	1
4	PF-RA-04-02	REDUCER	1
5	VPRO-2004	MUFFLER	2
6	VPRO-2002	GUARD	1
7	VPRO-2001	ACTUATOR	1
8	7701-6-4	TUBE FITTING	2
9	MPM-2598	ACTUATOR	2
10	D-S-012	O-RING	1
11	TRU-1021	ELBOW	2
12	7701-6-3	BARB FITTING	4
13	09073-6	TUBE	2
14	09073-5	TUBE	2
15	MPM-2584	TEE	1
16	MPM-2587	NUT	2
17	MPM-2583-1	TUBE	1
18	MPM-2583-16"	TUBE	1
19	MPM-2565	BARB FITTING	2
20	VPRO-2003	VALVE	1
21	F-MS-832-24	SCREW	2
22	7701-6-18	ELBOW	1
23	7304-3-1	SEAL	4
24	09127	PUSH BUTTON	2
25	F-SS-440-02-SS	SET SCREW	2

VPRO-45110-SK  
SEAL KIT - 11:1 PRO PUMP

1 PC  
O-B-157 O-RING

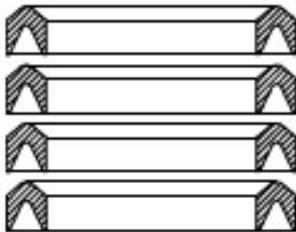
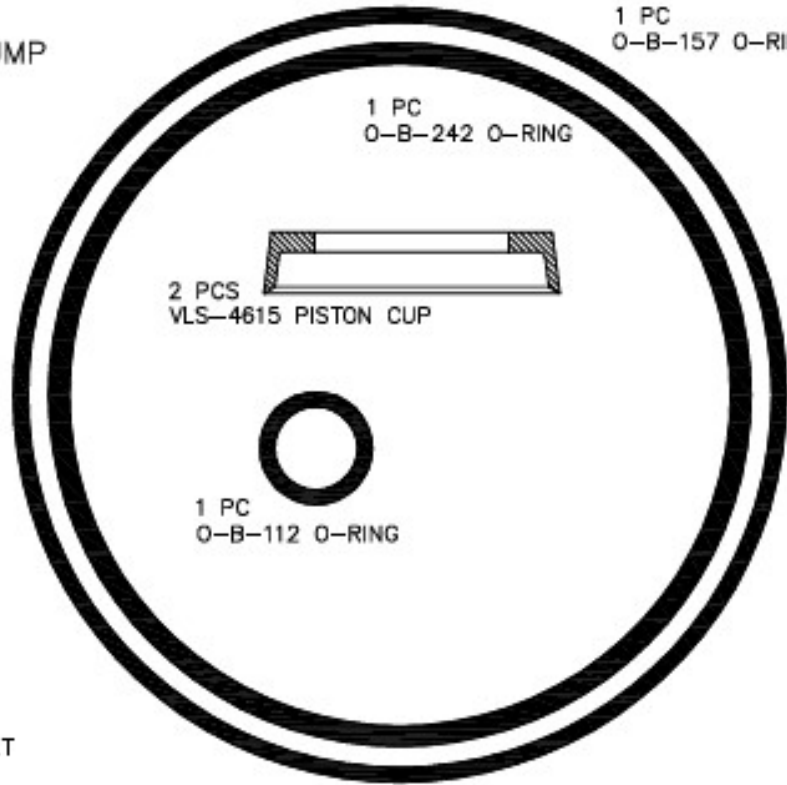
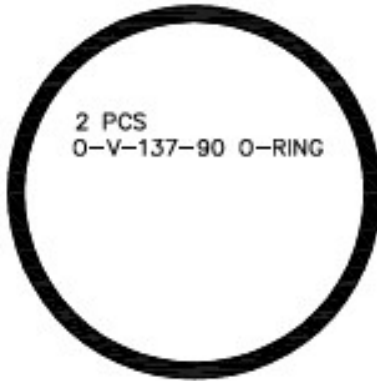

4 PCS  
VLS-4605 PISTON ROD PACKING SET

VPRO-45110-FP-SK  
SEAL KIT - 11:1 PRO PUMP (FLUSH)

1 PC  
O-B-157 O-RING

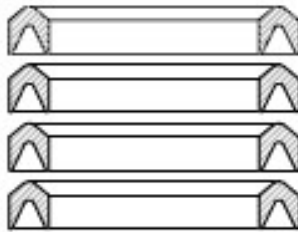
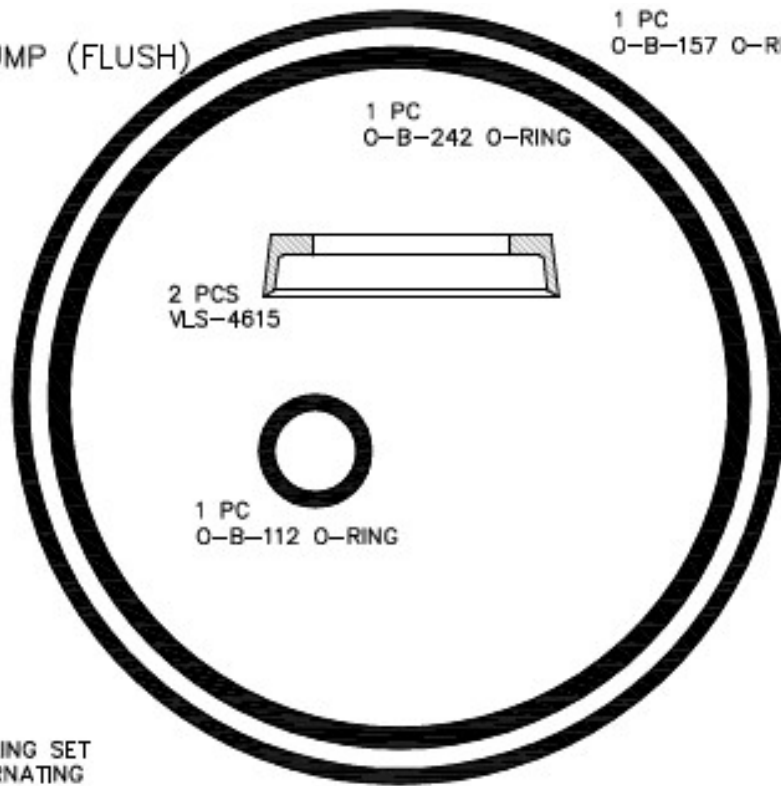

4 PCS  
VLS-4605-2U2G PISTON ROD PACKING SET  
(2 UHMW, 2 GLASS FILLED - ALTERNATING  
WITH UHMW ON BOTTOM)

VPRO-45110-FP-SK  
SEAL KIT - 11:1 PRO PUMP (FLUSH)

1 PC  
O-B-157 O-RING

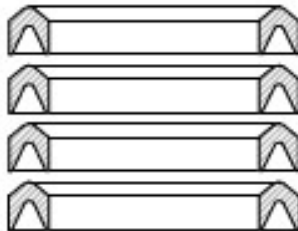
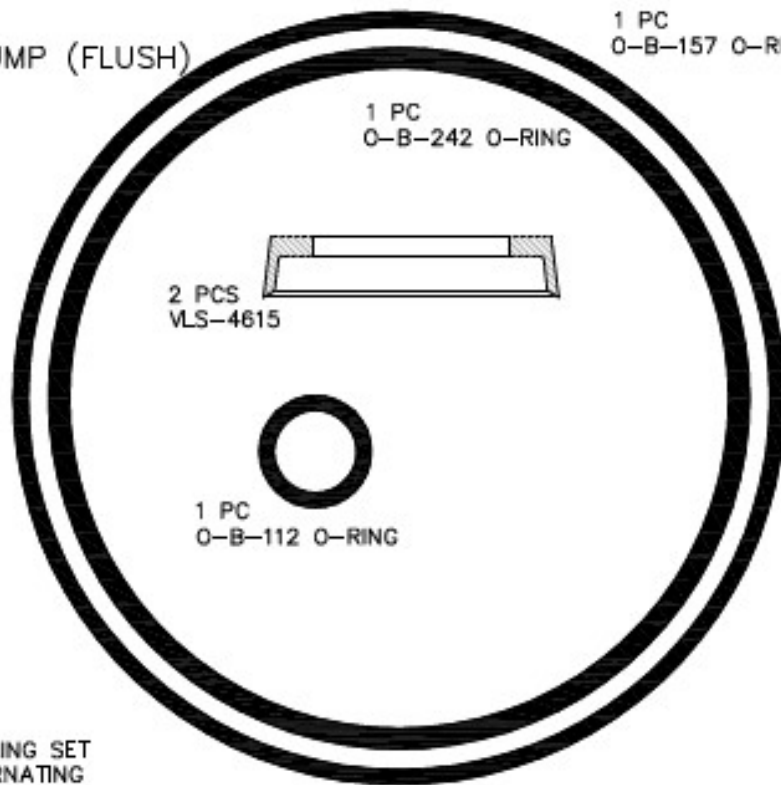
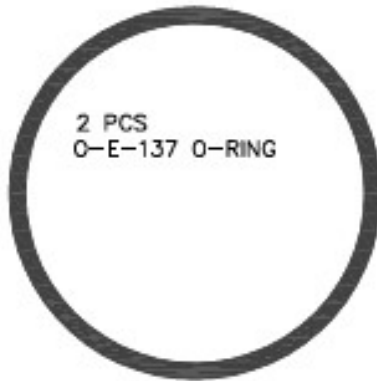

4 PCS  
VLS-4605-2U2G PISTON ROD PACKING SET  
(2 UHMW, 2 GLASS FILLED - ALTERNATING  
WITH UHMW ON BOTTOM)

VPRO-25400-SK  
SEAL KIT - 4:1 PRO PUMP

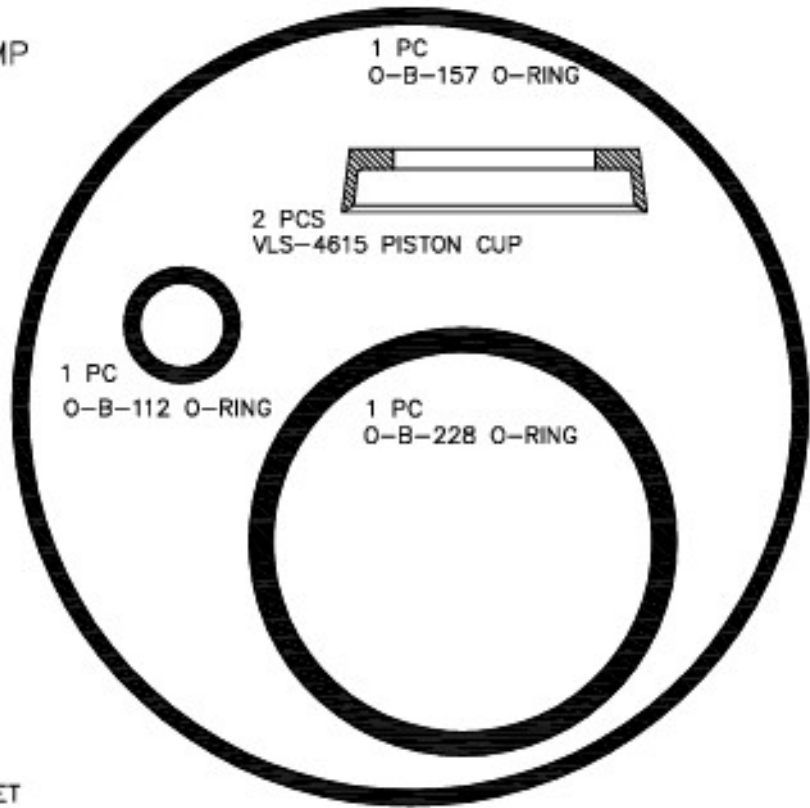
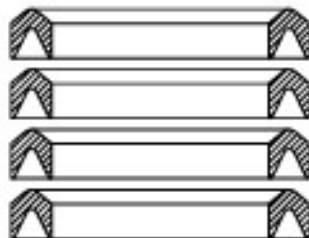

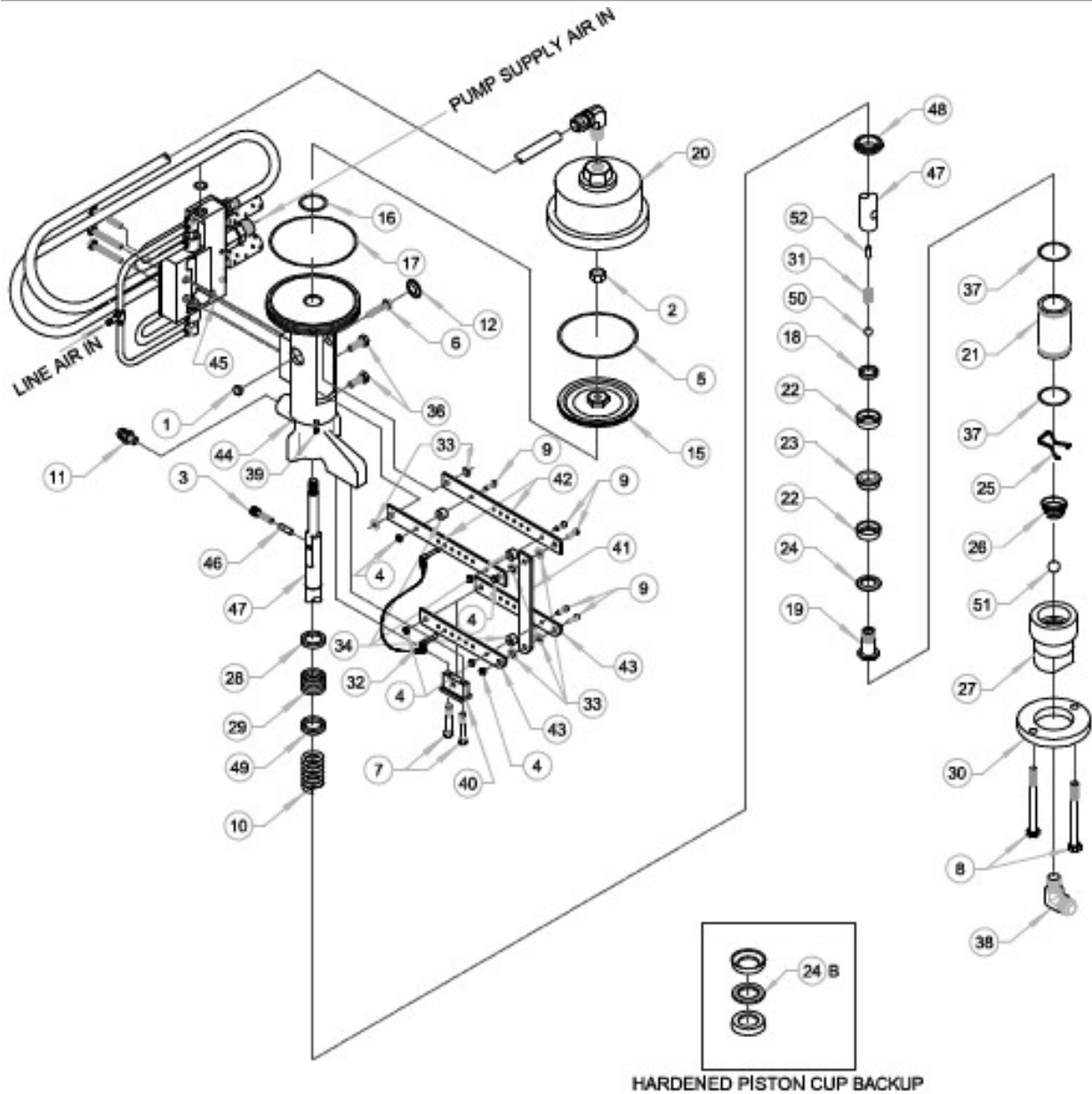

NOTE:  
THIS PUMP ASSY IS FOR EXTERNAL MIX ONLY

## MAGNUM VENUS PLASTECH

ASSY - 22 : 1 PRO PUMP

VPRO-45220

REV. F - REMOVED NOTE FOR EXTERNAL MIX ONLY 11/29/06 JEM  
 REV. G - UPDATED NUMBERS TO ALPHA-NUMERIC 12/01/10 BT2  
 REV. H - REMOVED ITEM 21B 19991-3, WHICH IS NO LONGER AVAILABLE 03/24/16 BT2  
 REV. I - REMOVED ITEM 23B 3102-11-1, WHICH IS NO LONGER AVAILABLE 10/05/17 BT2

## ASSY - 22 : 1 PRO PUMP VPRO-45220

## PARTS LIST

ITEM	PART NO.	QTY	DESCRIPTION
1	F-LN-04C	1	LOCK NUT
2	F-JN-07C	1	HEX NUT
3	F-CS-04C-24-SS	1	SOCKET HEAD CAP SCREW
4	F-LN-04F	6	LOCK NUT
5	O-B-242	1	O-RING
6	F-HB-04C-24	1	HEX BOLT
7	F-HB-05C-32	2	HEX BOLT
8	F-HB-06C-60-GR5	2	HEX BOLT
9	02966	6	AIRCRAFT BOLT
10	15950-1	1	LOWER PACKING SPRING
11	PF-SW-08	1	SWIVEL FITTING
12	15515	1	PLUG
15	15888-1	1	AIR MOTOR PISTON
16	O-B-112	1	O-RING
17	O-B-157	1	O-RING
18	VLS-2429	1	COMPRESSION RING
19	VLS-2419	1	PISTON BODY
20	15983-1	1	CYLINDER HEAD
21	15991-1	1	CYLINDER
22	VLS-2415	2	PISTON CUP
23	VLS-2418	1	PISTON CUP SPACER
24	VLS-2417	1	PISTON CUP BACKUP
25	VLS-2420	1	BALL STOP
26	3102-16-1	1	FOOT VALVE SPRING
27	VLS-2402	1	FOOT VALVE BODY
28	VLS-2404	1	FEMALE COMPRESSION RING
29	VLS-2405	1	PISTON ROD PACKING SPA
30	VLS-2424	1	FOOT VALVE COLLAR
31	VLS-2414	1	PISTON BALL SPRING
32	52108-3	1	QUICK PIN CABLE ASSY
33	VPRO-1006	6	SLAVE ARM BUSHING
34	VPRO-1005	3	SLAVE ARM SPACER
36	F-HB-05C-12	2	HEX BOLT
37	O-V-129	2	O-RING
38	PF-ME-12-12J	1	MALE ELBOW
39	7701-4-5	1	PLASTIC PLUG
40	VPRO-1007	1	MOUNT BLOCK
41	VPRO-1003-01	1	LINK BAR
42	VPRO-1001	2	UPPER SLAVE ARM
43	VPRO-1002	2	LOWER SLAVE ARM
44	85728-3	1	CENTER SECTION ASSY
45	VPRO-2000	1	SHIFT BLOCK ASSY
46	85806-1	1	TRIP SLEEVE
47	85716-1	1	PISTON ROD
48	15951-1	1	SPRING RETAINER
49	VLS-2406	1	MALE COMPRESSION RING
50	VLS-2426	1	1/2" CHROME BALL
51	VLS-2427	1	3/4" CHROME BALL
	95033-EN	1	PUMP PRIME CAUTION LABEL (NOT SHOWN)
	95099-1	1	SLAVE ARM DECAL (NOT SHOWN)
	95084-EN	1	AIR SHUT OFF CAUTION LABEL (NOT SHOWN)

## REPAIR KITS

PART NO.	DESCRIPTION
VPRO-45220-SK	SEAL KIT

## OPTIONAL PARTS AND ASSEMBLIES

ITEM	PART NO.	QTY	DESCRIPTION
24B	3102-12-2	1	HARDENED PISTON CUP BACKUP
52	VLS-2425	1	BALL STOP PIN

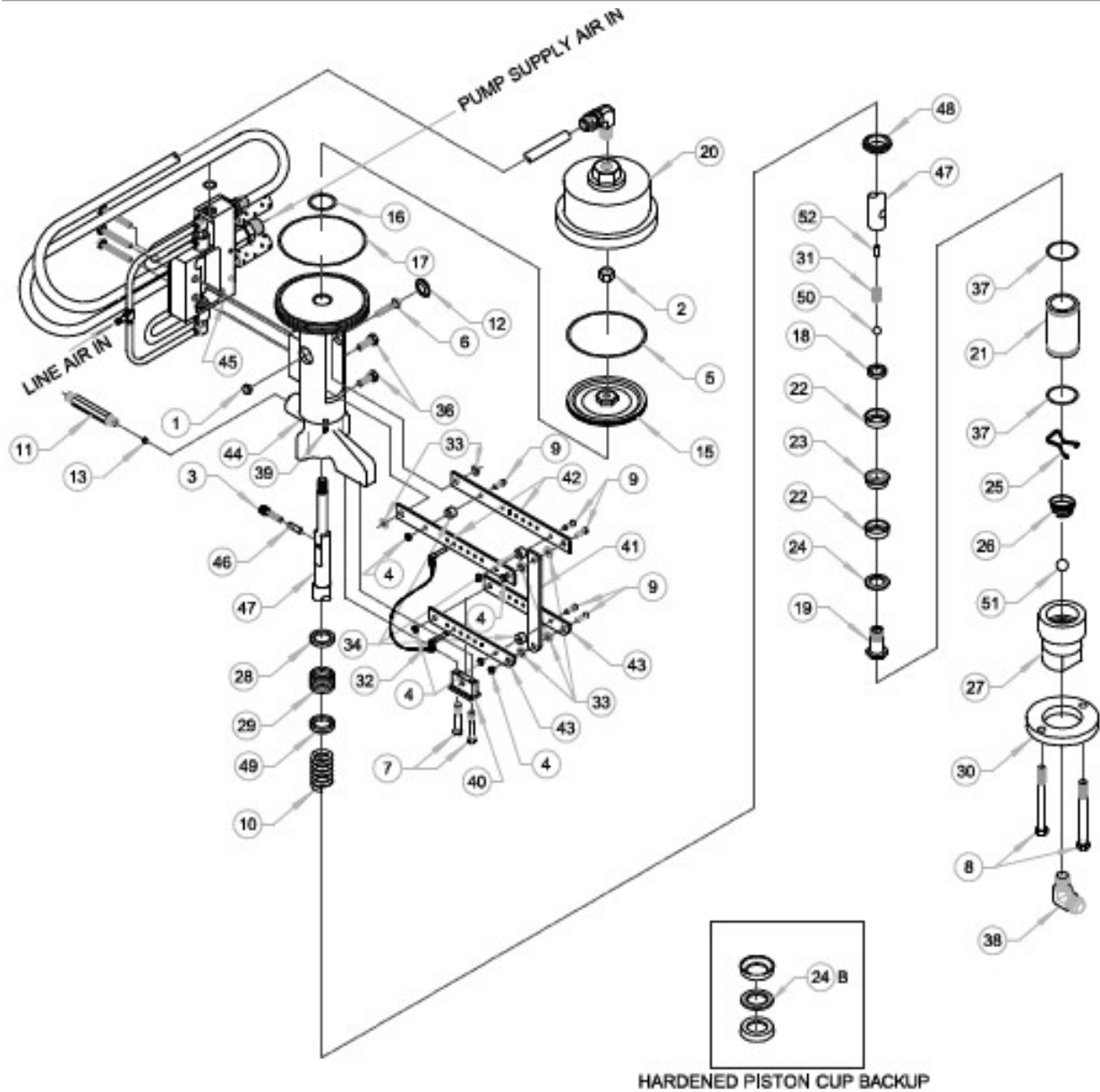

## MAGNUM VENUS PLASTECH

ASSY - 22 : 1 PRO PUMP

VPRO-45220-IM

REV. A - UPDATED NUMBERS TO ALPHA-NUMERIC 12/01/10 BT2  
 REV. B - ITEM 8 WAS F-HB-06C-60-GR5 07/28/12 BT2  
 REV. C - REMOVED ITEM 21B 18991-3, WHICH IS NO LONGER AVAILABLE 03/24/16 BT2  
 REV. D - REMOVED ITEM 23B 3102-11-1, WHICH IS NO LONGER AVAILABLE 10/05/17 BT2

**ASSY - 22 : 1 PRO PUMP VPRO-45220-IM  
PARTS LIST**

ITEM	PART NO.	QTY	DESCRIPTION
1	F-LN-04C	1	LOCK NUT
2	F-JN-07C	1	HEX NUT
3	F-CS-04C-24-SS	1	SOCKET HEAD CAP SCREW
4	F-LN-04F	6	LOCK NUT
5	O-B-242	1	O-RING
6	F-HB-04C-24	1	HEX BOLT
7	F-HB-05C-32	2	HEX BOLT
8	F-HB-06C-60-GR5	2	HEX BOLT
9	02986	6	AIRCRAFT BOLT
10	15950-1	1	LOWER PACKING SPRING
11	85712-1	1	FLOW CONTROL BODY
12	15515	1	PLUG
13	85713-1	1	FLOW CONTROL ORIFICE
15	15888-1	1	AIR MOTOR PISTON
16	O-B-112	1	O-RING
17	O-B-157	1	O-RING
18	VLS-2429	1	COMPRESSION RING
19	VLS-2419	1	PISTON BODY
20	15983-1	1	CYLINDER HEAD
21	15991-1	1	CYLINDER
22	VLS-2415	2	PISTON CUP
23	VLS-2416	1	PISTON CUP SPACER
24	VLS-2417	1	PISTON CUP BACKUP
25	VLS-2420	1	BALL STOP
26	3102-16-1	1	FOOT VALVE SPRING
27	VLS-2402	1	FOOT VALVE BODY
28	VLS-2404	1	FEMALE COMPRESSION RING
29	VLS-2405	1	PISTON ROD PACKING SPA
30	VLS-2424	1	FOOT VALVE COLLAR
31	VLS-2414	1	PISTON BALL SPRING
32	52106-3	1	QUICK PIN CABLE ASSY
33	VPRO-1006	6	SLAVE ARM BUSHING
34	VPRO-1005	3	SLAVE ARM SPACER
36	F-HB-05C-12	2	HEX BOLT
37	O-V-129	2	O-RING
38	PF-ME-12-12J	1	MALE ELBOW
39	7701-4-5	1	PLASTIC PLUG
40	VPRO-1007	1	MOUNT BLOCK
41	VPRO-1003-01	1	LINK BAR
42	VPRO-1001	2	UPPER SLAVE ARM
43	VPRO-1002	2	LOWER SLAVE ARM
44	85728-3	1	CENTER SECTION ASSY
45	VPRO-2000	1	SHIFT BLOCK ASSY
46	85806-1	1	TRIP SLEEVE
47	85716-1	1	PISTON ROD
48	15951-1	1	SPRING RETAINER
49	VLS-2406	1	MALE COMPRESSION RING
50	VLS-2426	1	1/2" CHROME BALL
51	VLS-2427	1	3/4" CHROME BALL
	95033-EN	1	PUMP PRIME CAUTION LABEL (NOT SHOWN)
	95099-1	1	SLAVE ARM DECAL (NOT SHOWN)
	95084-EN	1	AIR SHUT OFF CAUTION LABEL (NOT SHOWN)

**REPAIR KITS**

PART NO.	DESCRIPTION
VPRO-45220-SK	SEAL KIT

**OPTIONAL PARTS AND ASSEMBLIES**

ITEM	PART NO.	QTY	DESCRIPTION
24B	3102-12-2	1	HARDENED PISTON CUP BACKUP
52	7203-2-10	1	BALL STOP PIN

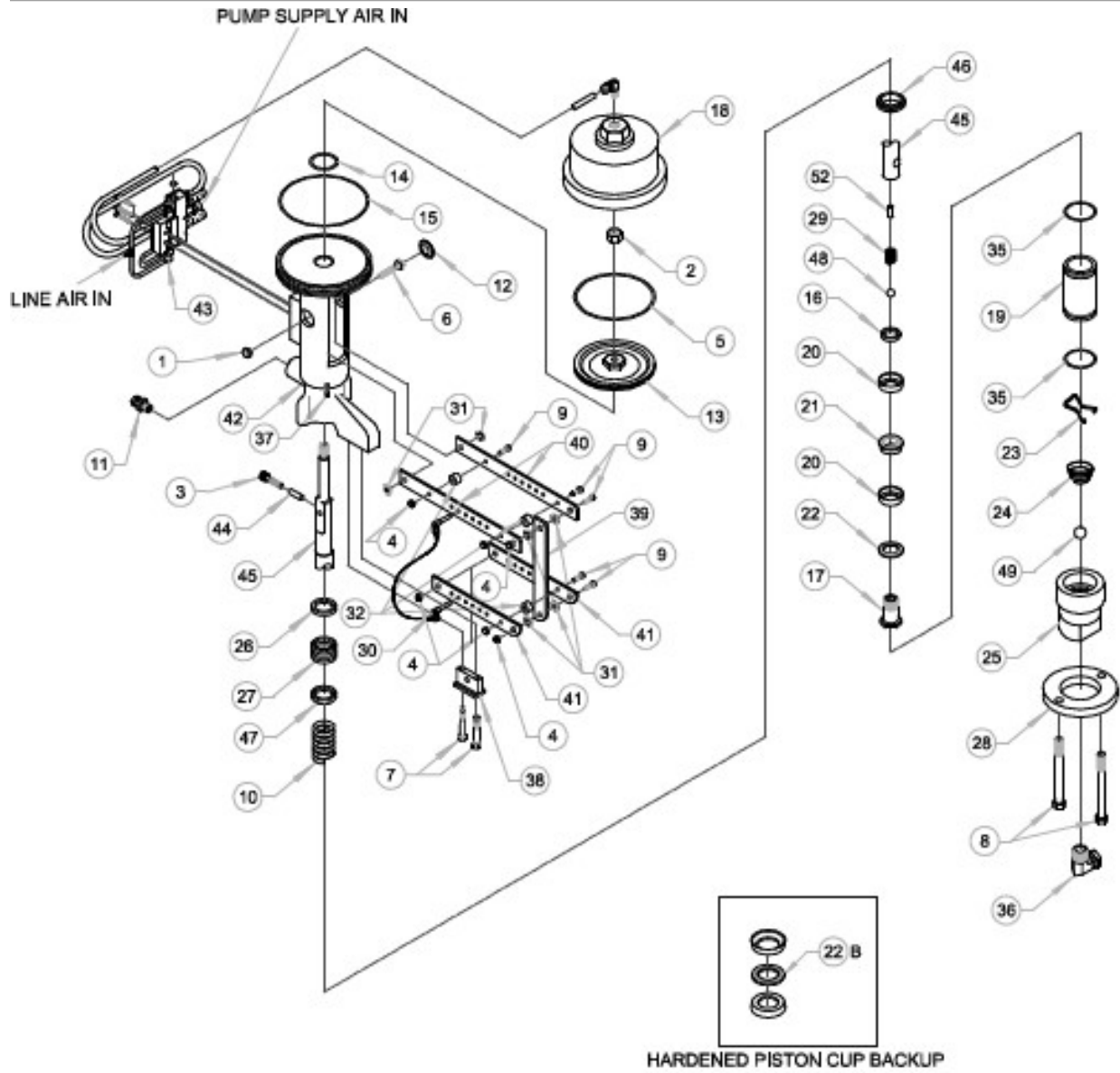

## MAGNUM VENUS PLASTECH

22 : 1 PRO PUMP - MULTI COLOR

VPRO-45220-MC

REV. - 03/02/11 BT2  
 REV. A - REMOVED ITEM 19B 15991-3, WHICH IS NO LONGER AVAILABLE 03/24/16 BT2  
 REV. B - REMOVED ITEM 21B 3102-11-1, WHICH IS NO LONGER AVAILABLE 10/05/17 BT2

## 22 : 1 PRO PUMP VPRO-45220-MC PARTS LIST

ITEM	PART NO.	QTY	DESCRIPTION
1	F-LN-04C	1	LOCK NUT
2	F-JN-07C	1	HEX NUT
3	F-CS-04C-24-SS	1	CAP SCREW
4	F-LN-04F	6	LOCK NUT
5	O-B-242	1	O-RING
6	F-HB-04C-24	1	HEX BOLT
7	F-HB-05C-32	2	HEX BOLT
8	F-HB-06C-60-GR5	2	HEX BOLT
9	02966	6	AIRCRAFT BOLT
10	15950-1	1	LOWER PACKING SPRING
11	PF-SW-06	1	HEX NIPPLE
12	15515	1	PLUG
13	15888-1	1	AJR MOTOR PISTON
14	O-B-112	1	O-RING
15	O-B-157	1	O-RING
16	VLS-2429	1	COMPRESSION RING
17	VLS-2419	1	PISTON BODY
18	15883-1	1	CYLINDER HEAD
19	15991-1	1	CYLINDER
20	VLS-2415	2	PISTON CUP
21	VLS-2416	1	PISTON CUP SPACER
22	VLS-2417	1	PISTON CUP BACKUP
23	VLS-2420	1	BALL STOP
24	3102-16-1	1	FOOT VALVE SPRING
25	VLS-2402	1	FOOT VALVE BODY
26	VLS-2404	1	FEMALE COMPRESSION RING
27	VLS-2405	1	PISTON ROD PACKING SPA
28	VLS-2424	1	FOOT VALVE COLLAR
29	VLS-2414	1	PISTON BALL SPRING
30	52106-3	1	QUICK PIN CABLE ASSY.
31	VPRO-1006	6	SLAVE ARM BUSHING
32	VPRO-1005	3	SLAVE ARM SPACER
35	O-V-129	2	O-RING
36	PF-SE-SW-12	1	SWIVEL STREET ELBOW
37	7701-4-5	1	PLASTIC PLUG
38	VPRO-1007	1	MOUNT BLOCK
39	VPRO-1003-01	1	LINK BAR
40	VPRO-1001	2	UPPER SLAVE ARM
41	VPRO-1002	2	LOWER SLAVE ARM
42	85728-3	1	CENTER SECTION ASSY.
43	VPRO-2000	1	SHIFT BLOCK ASSY
44	85806-2	2	TRIP SLEEVE
45	85716-1	1	PISTON ROD
46	15951-1	1	SPRING RETAINER
47	VLS-2406	1	MALE COMPRESSION RING
48	VLS-2428	1	1/2" CHROME BALL
49	VLS-2427	1	3/4" CHORME BALL
	95033-EN	1	PUMP PRIME CAUTION LABEL (NOT SHOWN)
	95099-1	1	SLAVE ARM DECAL (NOT SHOWN)
	95084-EN	1	AIR SHUT OFF CAUTION LABEL (NOT SHOWN)

## REPAIR KITS

PART NO.	DESCRIPTION
VPRO-45220-SK	SEAL KIT

## OPTIONAL PARTS AND ASSEMBLIES

ITEM	PART NO.	QTY	DESCRIPTION
22B	3102-12-2	1	HARDENED PISTON CUP BACKUP
52	VLS-2425	1	BALL STOP PIN

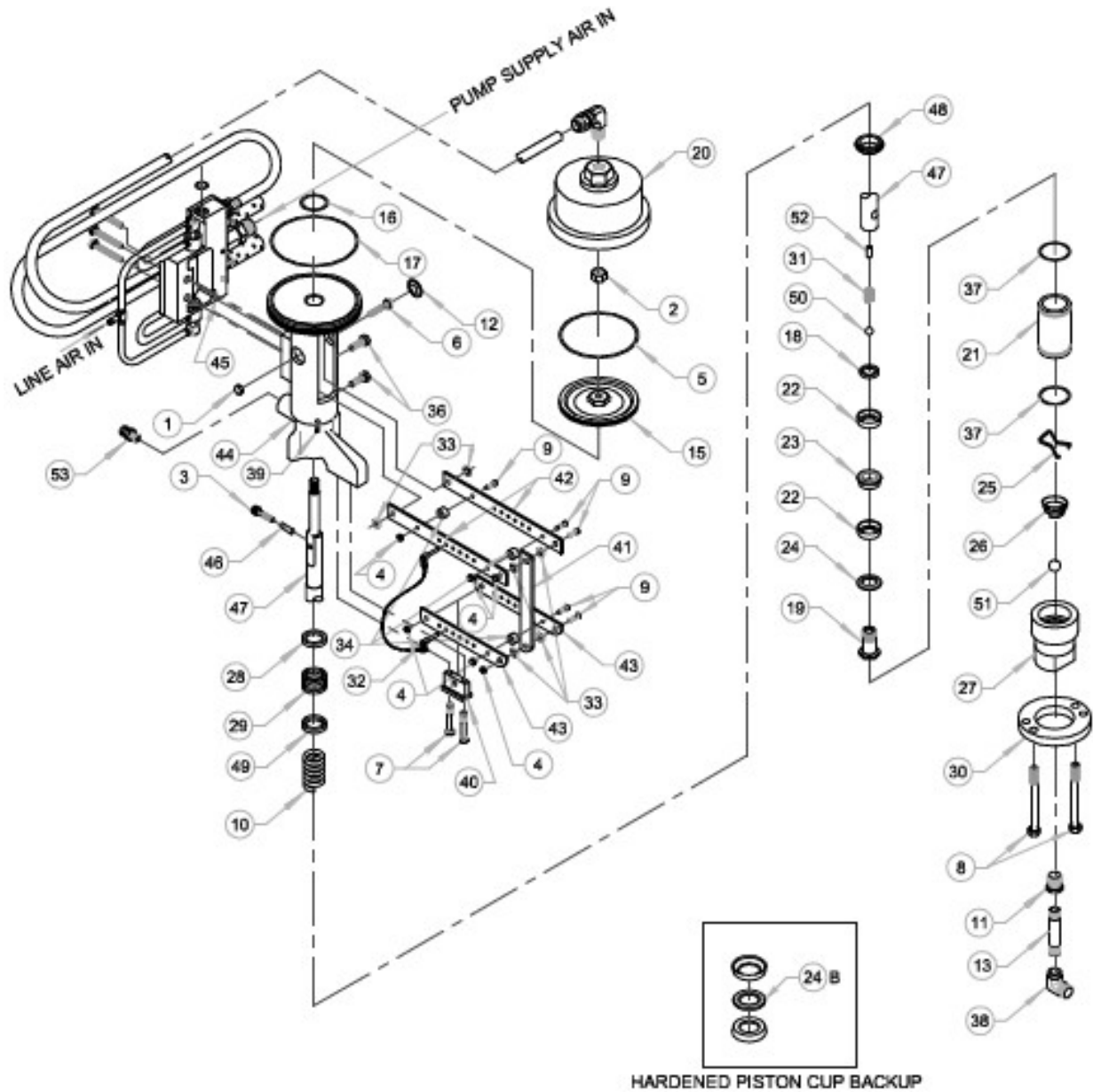

NOTE:  
THIS PUMP ASSY IS FOR EXTERNAL MIX ONLY

## MAGNUM VENUS PRODUCTS

22 : 1 PRO RIDER PUMP

VPRO-45220-NPR

REV. A = ADDED ITEM 53 PF-SW-06 11/01/05 BT2  
 REV. B = REMOVED NOTE FOR EXTERNAL MIX ONLY 11/25/06 JEM  
 REV. C = REMOVED ITEM 21B 15991-3, WHICH IS NO LONGER AVAILABLE 03/24/16 BT2  
 REV. D = REMOVED ITEM 23B 3102-11-1, WHICH IS NO LONGER AVAILABLE 10/05/17 BT2

## 22 : 1 PRO RIDER PUMP VPRO-45220-NPR

## PARTS LIST

ITEM	PART NO.	QTY	DESCRIPTION
1	F-LN-04C	1	NYLOCK HEX NUT
2	F-JN-07C	1	HEX NUT
3	F-CS-04C-24-SS1	1	CAP SCREW
4	F-LN-04F	6	LOCK NUT
* 5	O-B-242	1	O-RING
6	F-HB-04C-24	1	HEX BOLT
7	F-HB-05C-32	2	HEX BOLT
8	F-HB-06C-60-GR5	2	HEX BOLT
9	02966	6	AIRCRAFT BOLT
10	15950-1	1	LOWER PACKING SPRING
11	PF-RB-12-08	1	REDUCER BUSHING
12	15515	1	PLUG
13	PF-HN-08L	1	LONG NIPPLE
15	15888-1	1	AIR MOTOR PISTON
* 16	O-B-112	1	O-RING
* 17	O-B-157	1	O-RING
18	VLS-2429	1	COMPRESSION RING
19	VLS-2419	1	PISTON BODY
20	15983-1	1	CYLINDER HEAD
21	15991-1	1	CYLINDER
* 22	VLS-2415	2	PISTON CUP
23	VLS-2416	1	PISTON CUP SPACER
24	VLS-2417	1	PISTON CUP BACKUP
25	VLS-2420	1	BALL STOP
26	3102-16-1	1	FOOT VALVE SPRING
27	VLS-2402	1	FOOT VALVE BODY
28	VLS-2404	1	FEMALE COMPRESSION SPRING
* 29	VLS-2405	1	PISTON ROD PACKING SPA
30	VLS-2424	1	FOOT VALVE COLLAR
31	VLS-2414	1	PISTON BALL SPRING
32	52106-3	1	QUICK PIN CABLE ASSY
33	VPRO-1006	6	SLAVE ARM BUSHING
34	VPRO-1005	3	SLAVE ARM SPACER
36	F-HB-05C-12	2	HEX BOLT
* 37	O-V-129	2	O-RING
38	PF-SE-08	1	STREET ELBOW
39	7701-4-5	1	PLASTIC PLUG
40	VPRO-1007	1	MOUNT BLOCK
41	VPRO-1003-01	1	LINK BAR
42	VPRO-1001	2	UPPER SLAVE ARM
43	VPRO-1002	2	LOWER SLAVE ARM
44	85728-3	1	CENTER SECTION ASSY
45	VPRO-2000	1	SHIFT BLOCK ASSY
46	85806-1	1	TRIP SLEEVE
47	85716-1	1	PISTON ROD
48	15951-1	1	SPRING RETAINER
49	VLS-2406	1	MALE COMPRESSION RING
50	VLS-2426	1	1/2" CHROME BALL
51	VLS-2427	1	CHROME BALL
53	PF-SW-06	1	SWIVEL
	95033-EN	1	PUMP PRIME CAUTION LABEL (NOT SHOWN)
	95099-1	1	SLAVE ARM DECAL (NOT SHOWN)
	95084-EN	1	AIR SHUT OFF CAUTION LABEL (NOT SHOWN)

## REPAIR KITS

PART NO.	DESCRIPTION
* VPRO-45220-SK	SEAL KIT

## OPTIONAL PARTS AND ASSEMBLIES

ITEM	PART NO.	QTY	DESCRIPTION
24B	3102-12-2	1	HARDENED PISTON CUP BACKUP
52	7203-2-10	1	BALL STOP PIN

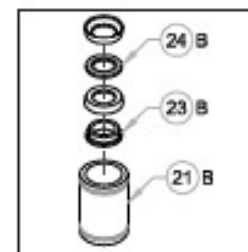
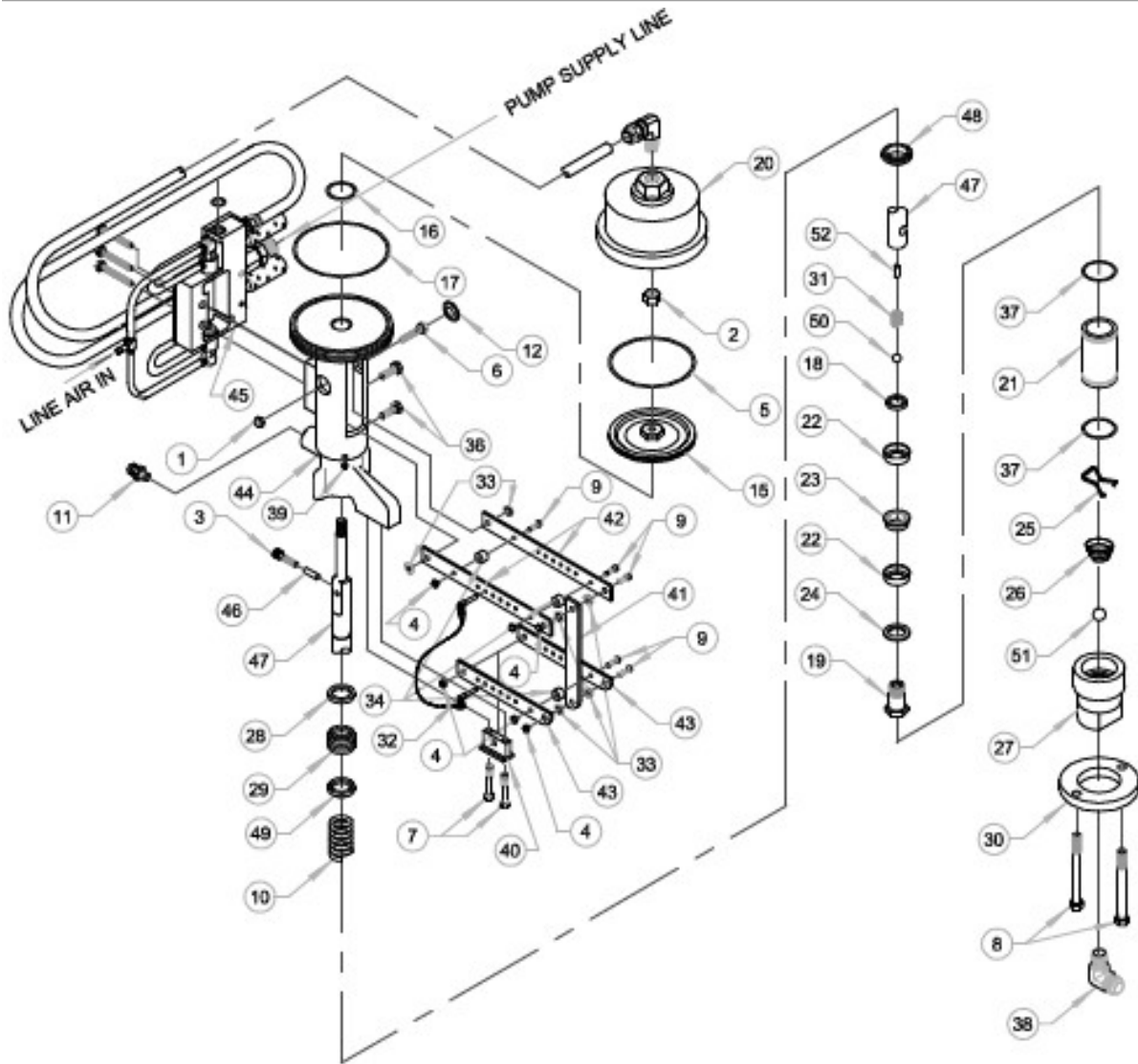

ABRASIVE KIT

# MAGNUM VENUS PLASTECH

ASSY - 7 : 1 PRO PUMP

VPRO-25700

REV. - 11/9/04 JEM  
 REV. A = REMOVED NOTE FOR EXTERNAL MIX ONLY 11/29/06 JEM  
 REV. B = UPDATED TO ALPHA NUMERIC, CORRECTED ITEM 15 11/04/09 BT2

**ASSY - 7 : 1 PRO PUMP VPRO-25700****PARTS LIST**

ITEM	PART NO.	QTY	DESCRIPTION
1	F-LN-04C	1	NYLOCK HEX NUT
2	F-JN-07C	1	HEX NUT
3	F-CS-04C-24-SS	1	SOCKET HEAD CAP SCREW
4	F-LN-04F	6	LOCK NUT
5	O-B-228	1	O-RING
6	F-HB-04C-24	1	HEX BOLT
7	F-HB-05C-32	2	HEX BOLT
8	F-HB-06C-60-GR5	2	HEX BOLT
9	02966	6	AIRCRAFT BOLT
10	15950-1	1	LOWER PACKING SPRING
11	PF-SW-08	1	SWIVEL FITTING
12	15515	1	PLUG
15	VPRO-25402	1	AIR MOTOR PISTON
16	O-B-112	1	O-RING
17	O-B-157	1	O-RING
18	VLS-2429	1	COMPRESSION RING
19	VLS-2419	1	PISTON BODY
20	VPRO-25401	1	CYLINDER HEAD
21	15991-1	1	CYLINDER
22	VLS-2415	2	PISTON CUP
23	VLS-2416	1	PISTON CUP SPACER
24	VLS-2417	1	PISTON CUP BACKUP
25	VLS-2420	1	BALL STOP
26	3102-16-1	1	FOOT VALVE SPRING
27	VLS-2402	1	FOOT VALVE BODY
28	VLS-2404	1	FEMALE COMPRESSION RING
29	VLS-2405	1	PISTON ROD PACKING SPA
30	VLS-2424	1	FOOT VALVE COLLAR
31	VLS-2414	1	PISTON BALL SPRING
32	52106-3	1	QUICK PIN CABLE ASSY
33	VPRO-1008	6	SLAVE ARM BUSHING
34	VPRO-1005	3	SLAVE ARM SPACER
36	F-HB-05C-12	2	HEX CAP SCREW
37	O-V-129	2	O-RING
38	PF-ME-12-12J	1	MALE ELBOW
39	7701-4-5	1	PLASTIC PLUG
40	VPRO-1007	1	MOUNT BLOCK
41	VPRO-1003-01	1	LINK BAR
42	VPRO-1001	2	UPPER SLAVE ARM
43	VPRO-1002	2	LOWER SLAVE ARM
44	85728-3	1	CENTER SECTION ASSY
45	VPRO-2000	1	SHIFT BLOCK ASSY
46	85808-1	1	TRIP SLEEVE
47	85716-1	1	PISTON ROD
48	15951-1	1	SPRING RETAINER
49	VLS-2406	1	MALE COMPRESSION RING
50	VLS-2426	1	1/2" CHROME BALL
51	VLS-2427	1	3/4" CHROME BALL
	95033-EN	1	PUMP PRIME CAUTION LABEL (NOT SHOWN)
	95099-1	1	SLAVE ARM DECAL (NOT SHOWN)
	95084-EN	1	AIR SHUT OFF CAUTION LABEL (NOT SHOWN)

**REPAIR KITS**

PART NO.	DESCRIPTION
VPRO-25700-SK	SEAL KIT

**OPTIONAL PARTS AND ASSEMBLIES**

ITEM	PART NO.	QTY	DESCRIPTION
21B	15991-3	1	HARDENED CYLINDER
23B	3102-11-2	1	HARDENED PISTON CUP SPACER
24B	3102-12-2	1	HARDENED PISTON CUP BACKUP
52	VLS-2425	1	BALL STOP PIN

VPRO-45220-SK  
SEAL KIT - 22:1 PRO PUMP

1 PC  
O-B-157 O-RING

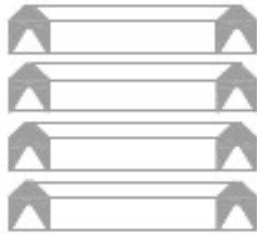
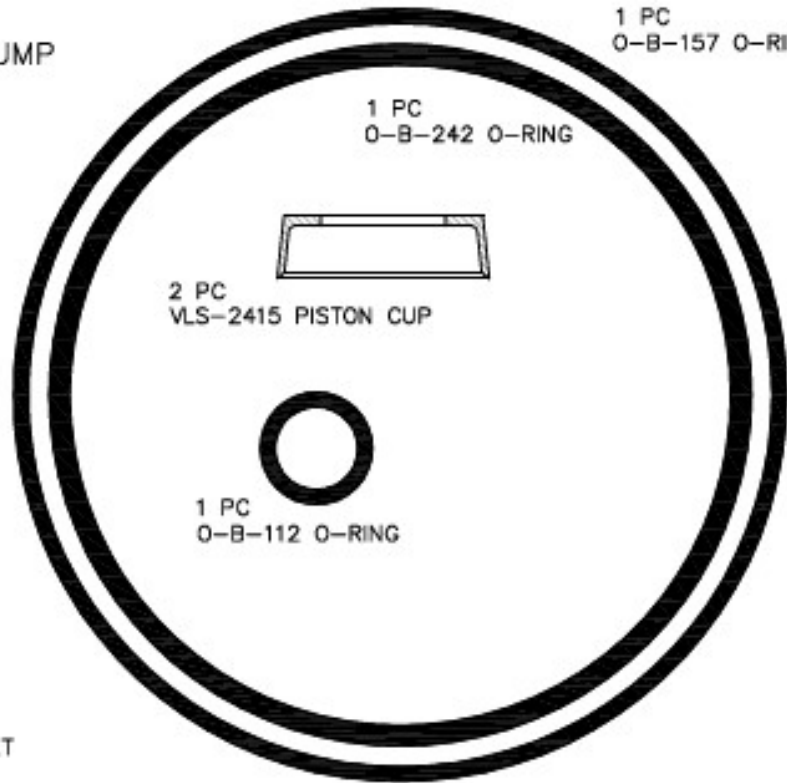

4 PCS  
VLS-2405 PISTON ROD PACKING SET

VPRO-25700-SK  
SEAL KIT - 7:1 PRO PUMP

1 PC  
O-B-157 O-RING

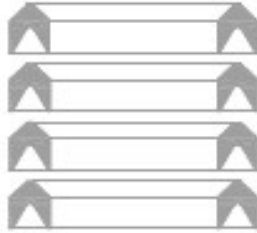
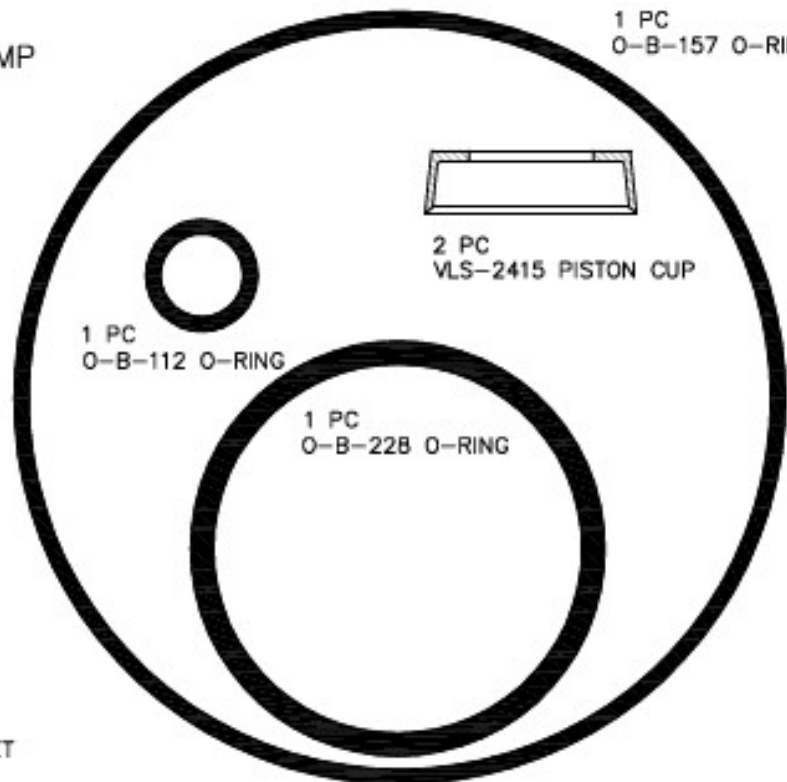

4 PCS  
VLS-2405 PISTON ROD PACKING SET



**Magnum Industries Europe Ltd. t/a Magnum Venus Products**

*Official Distributor of MVP Range in the United Kingdom and Ireland*

Unit 22a, Navigation Drive, Hurst Business Park,  
Brierley Hill, West Midlands, DY5 1UT, UK.

**phone:** +44 (0)1384 486222  
**email:** [info@mvpeurope.co.uk](mailto:info@mvpeurope.co.uk)  
**website:** [www.mvpeurope.co.uk](http://www.mvpeurope.co.uk)