

Patriot Pro Innovator 2

Operations Manual

This manual is applicable
to the following models:

- INV2-PAT-7-PRO

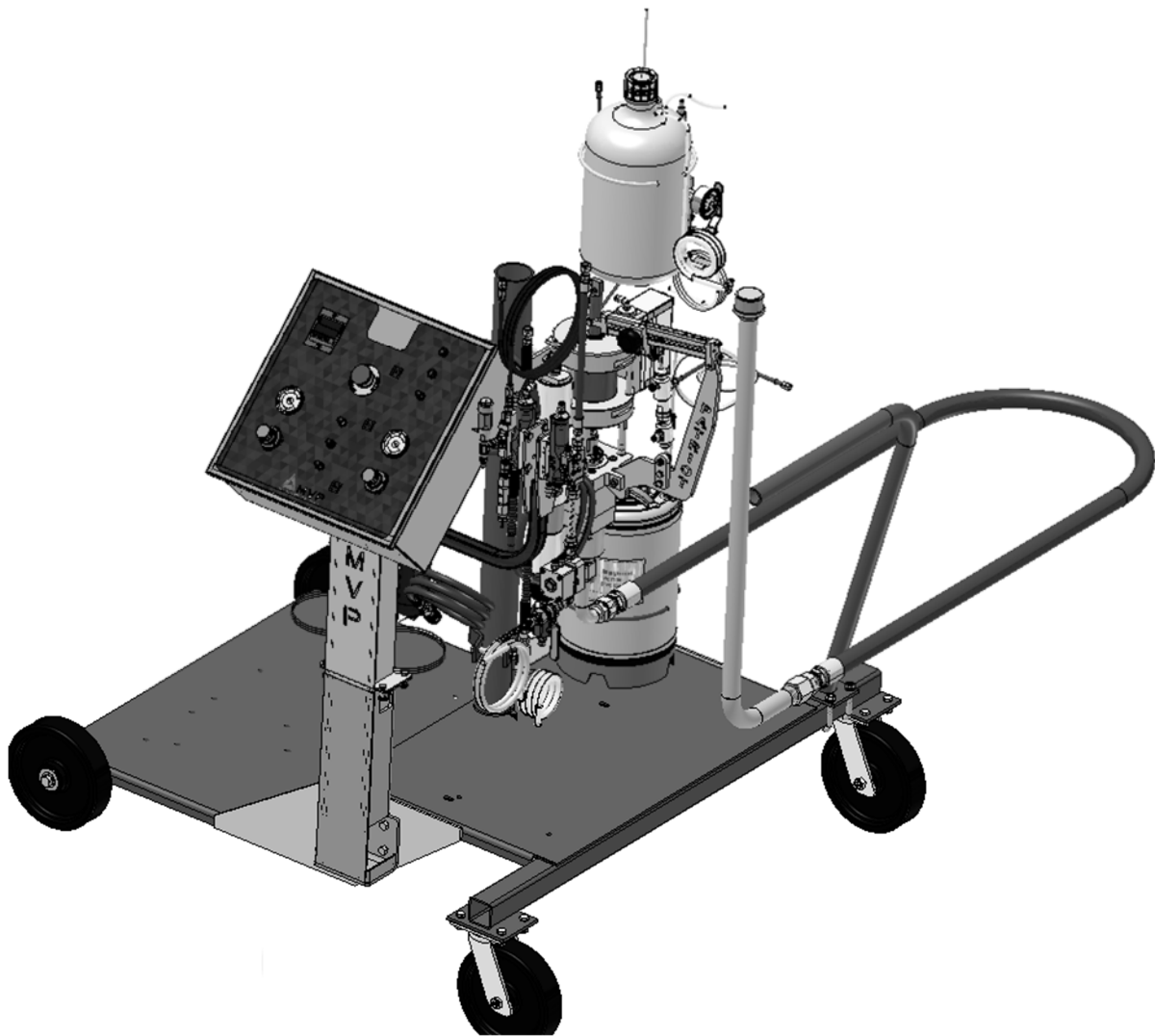



Magnum Industries Europe Ltd. t/a Magnum Venus Products

Official Distributor of MVP Range in the United Kingdom and Ireland

Unit 22a, Navigation Drive, Hurst Business Park,
Brierley Hill, West Midlands, DY5 1UT, UK.

phone: +44 (0)1384 486222
email: info@mvpeurope.co.uk
website: www.mvpeurope.co.uk



Table of Contents

Section	Page
• Table of Contents	3
• Safety & Warning Information	4
• Introduction	15
• Adjusting Settings	21
• Getting Started	24
• Performing a Gel Test	25
• Performing Daily Tasks	26
• Maintenance	27
• Troubleshooting	28

Safety & Warning Information

Warnings

Due to the vast number of chemicals that could be used and their varying chemical reactions, the buyer and user of this equipment should determine all factors relating to the fluids used, including any of the potential hazards involved. Particular inquiry and investigation should be made into potential dangers relating to toxic fumes, fires, explosions, reaction times, and exposure of human beings to the individual components or their resultant mixtures. MVP assumes no responsibility for loss, damage, expense or claims for bodily injury or property damage, direct or consequential, arising from the use of such chemical components.

The end user is responsible for ensuring that the end product or system complies with all the relevant laws in the country where it is to be used and that all documentation is adhered to.

Recommended Occupational Safety & Health Act (OSHA) Documentation:

- 1910.94 Pertaining to ventilation
- 1910.106 Pertaining to flammable liquids
- 1910.107 Pertaining to spray finishing operations, particularly paragraph (m), Organic Peroxides and Dual Component Coatings

For Additional information, contact the Occupational Safety and Health Administration (OSHA) at <https://www.osha.gov/about.html>.

Recommended National Fire Protection Association (NFPA) Documentation:

- NFPA No.33 Chapter 14 Organic Peroxides and Dual Component Materials
- NFPA No. 63 Dust Explosion Prevention
- NFPA No. 70 National Electrical Code
- NFPA No. 77 Static Electricity
- NFPA No. 91 Blower and Exhaust System
- NFPA No. 654 Plastics Industry Dust Hazards

Fire Extinguisher – code ABC, rating number 4a60bc using Extinguishing Media –Foam, Carbon Dioxide, Dry Chemical, Water Fog, is recommended for this product and applications.

The following general warnings and guidelines are for the setup, use, grounding, maintenance, and repair of equipment. Additional product-specific warnings may be found throughout this manual as applicable. Please contact your nearest MVP Technical Service Representative if additional information is needed.

Safety Precautions

- Avoid skin contact and inhalation of all chemicals.
- Review Material Safety Data Sheet (MSDS) to promote the safe handling of chemicals in use.
- Restrict the use of all chemicals to designated areas with good ventilation.
- Chemicals are flammable and reactive.
- Noxious fumes released when combusted.
- Operate equipment in a ventilated environment only.
- Uncured liquid resins are highly flammable unless specifically labeled otherwise.
- Cured laminate, accumulations of overspray, and laminate sandings are highly combustible.
- Do not operate or move electrical equipment when flammable fumes are present.
- Ground all equipment.
- If a spark is seen or felt, immediately halt operation. Do not operate the equipment until the issue has been identified and repaired.
- Contaminated catalyst may cause fire or explosion.
- Containers may explode if exposed to fire / heat.
- Use and store chemicals away from heat, flames, and sparks.
- Do not smoke in work areas or near stored chemicals.
- Do not mix Methyl Ethyl Ketone Peroxide (MEKP) with materials other than polyethylene.
- Do not dilute MEKP.
- Keep food and drink away from work area.



Physical Hazards

- Never look directly into the spray gun fluid tip. Serious injury or death can result.
- Never aim the spray gun at or near another person. Serious injury or death can result.
- Chemical compounds can be severely irritating to the eyes and skin.
- Inhalation, ingestion, or injection may damage internal organs and lead to pulmonary disorders, cancers, lymphomas, and other diseases or health conditions.
- Other potential health effects include: irritation of the eyes and upper respiratory tract, headache, light-headedness, dizziness, confusion, drowsiness, nausea, vomiting, and occasionally abdominal pain.
- Eye contact: Immediately flush with water for at least 15 minutes and seek immediate medical attention.
- Skin Contact: Immediately wash with soap and water and seek immediate medical attention.
- Inhalation: Move the person to fresh air and seek immediate medical attention.
- Do not remove shields, covers, or safety features on equipment that is in use.
- Never place fingers, hands, or any body part near or directly in front of the spray gun fluid tip. The force of the liquid as it exits the spray tip can shoot liquid through the skin.
- Keep hands and body parts away from any moving equipment or components.
- Do not stand under plunger
- An improperly loaded drum may lead to an imbalance, causing a unit to tip over

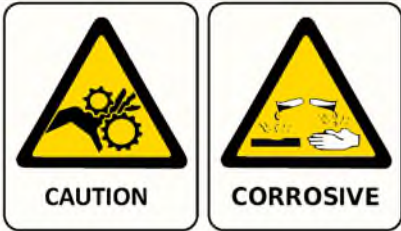

Personal Protective Equipment (PPE)

- MVP recommends the use of personal safety equipment with all products in our catalog.
- Wear safety goggles, hearing protection, a respirator, and chemical resistant gloves.
- Wear long sleeve shirts or jackets and pants to minimize skin exposure.
- PPE should be worn by operators and service technicians to reduce the risk of injury.



For Additional information, contact the Occupational Safety and Health Administration (OSHA). <https://www.osha.gov/about.html>

Symbol Definitions



Indicates the risk of contact with chemicals that are hazardous, which may lead to injury or death.



Indicates the risk of contact with voltage / amperage that may lead to serious injury or death.



Indicates that the materials being used are susceptible to combustion.



Indicates the risk of contact with moving components that may lead to serious injury or death.



Indicates that the system or component should be grounded before proceeding with use or repair.



Indicates the use of lit cigarettes or cigars is prohibited, because the materials being used are susceptible to combustion.



Indicates that the materials and/or the process being performed can lead to ignition and explosion.



A recommendation for the use of Personal Protective Equipment (PPE) before using or repairing the product.

Polymer Matrix Materials: Advanced Composites

Potential health hazards associated with the use of advanced composites can be controlled through the implementation of an effective industrial hygiene and safety program.

https://www.osha.gov/dts/osta/otm/otm_iii/otm_iii_1.html#t_iii:1_1

Resins		
Composite Component	Organ System Target (Possible Target)	Known (Possible) Health Effect
Epoxy resins	Skin, lungs, eyes	Contact and allergic dermatitis, conjunctivitis
Polyurethane resins	Lungs, skin, eyes	Respiratory sensitization, contact dermatitis, conjunctivitis
Phenol formaldehyde	Skin, lungs, eyes	As above (potential carcinogen)
Bismaleimides (BMI)	Skin, lungs, eyes	As above (potential carcinogen)
Polyamides	Skin, lungs, eyes	As above (potential carcinogen)
Reinforcing materials		
Composite Component	Organ System Target (Possible Target)	Known (Possible) Health Effect
Aramid fibers	Skin (lungs)	Skin and respiratory irritation, contact dermatitis (chronic interstitial lung disease)
Carbon/graphite fibers	Skin (lungs)	As noted for aramid fibers
Glass fibers (continuous filament)	Skin (lungs)	As noted for aramid fibers
Hardeners and curing agents		
Composite Component	Organ System Target (Possible Target)	Known (Possible) Health Effect
Diaminodiphenylsulfone	N/A	No known effects with workplace exposure
Methylenedianiline	Liver, skin	Hepatotoxicity, suspect human carcinogen
Other aromatic amines		
Composite Component	Organ System Target (Possible Target)	Known (Possible) Health Effect
Meta-phenylenediamine (MPDA)	Liver, skin (kidney, bladder)	Hepatitis, contact dermatitis (kidney and bladder cancer)
Aliphatic and cyclo-aliphatic amines	Eyes, skin	Severe irritation, contact dermatitis
Polyaminoamide	Eyes, skin	Irritation (sensitization)
Anhydride	Eyes, lungs, skin	Severe eye and skin irritation, respiratory sensitization, contact dermatitis

Catalyst - Methyl Ethyl Ketone Peroxide (MEKP)

MEKP is among the more hazardous materials found in commercial channels. The safe handling of the “unstable (reactive)” chemicals presents a definite challenge to the plastics industry. The highly reactive property which makes MEKP valuable to the plastics industry in producing the curing reaction of polyester resins also produces the hazards which require great care and caution in its storage, transportation, handling, processing and disposal. MEKP is a single chemical. Various polymeric forms may exist which are more or less hazardous with respect to each other. These differences may arise not only from different molecular structures (all are, nevertheless, called “MEKP”) and from possible trace impurities left from the manufacture of the chemicals, but may also arise by contamination of MEKP with other materials in its storage or use. Even a small amount of contamination with acetone, for instance, may produce an extremely shock-sensitive and explosive compound.



WARNING

Contamination with promoters, materials containing promoters (such as laminate sandings), or with any readily oxidizing material (such as brass or iron) will cause exothermic redox reactions which can be explosive in nature. Heat applied to MEKP or heat buildup from contamination reactions can cause the material to reach its Self-Accelerating Decomposition Temperature (SADT).

Researchers have reported measuring pressure rates-of-rise well over 100,000 psi per second when certain MEKP's reach their SADT. For comparison, the highest-pressure rate-of-rise listed in NFPA Bulletin NO.68, “Explosion Venting”, is 12,000 psi per second for an explosion of 12% acetylene and air. The maximum value listed for a hydrogen explosion is 10,000 psi per second. Some forms of MEKP, if allowed to reach their SADT, will burst even an open topped container. This suggests that it is not possible to design a relief valve to vent this order of magnitude of pressure rate-of-rise. The user should be aware that any closed container, be it a pressure vessel, surge chamber, or pressure accumulator, could explode under certain conditions. There is no engineering substitute for care by the user in handling organic peroxide catalysts. If, at any time, the pressure relieve valve on top of the catalyst tank should vent, the area should be evacuated at once and the fire department called. The venting could be the first indication of a heat, and therefore, pressure build-up that could eventually lead to an explosion. Moreover, if a catalyst tank is sufficiently full when the pressure relief valve vents, some catalyst may spray out, which could cause eye injury. For this reason, and many others, anyone whose job puts them in an area where this vented spray might go, should always wear full eye protection even when laminating operations are not taking place.

Safety in handling MEKP depends to a great extent on employee education, proper safety instructions, and safe use of the chemicals and equipment. Workers should be thoroughly informed of the hazards that may result from improper handling of MEKP, especially regarding contamination, heat, friction and impact. They should be thoroughly instructed regarding the proper action to be taken in the storage, use, and disposal of MEKP and other hazardous materials used in the laminating operation. In addition, users should make every effort to:

- Store MEKP in a cool, dry place in original containers away from direct sunlight and away from other chemicals.
- Keep MEKP away from heat, sparks, and open flames.

- Prevent contamination or MEKP with other materials, including polyester over spray and sandings, polymerization accelerators and promoters, brass, aluminum, and non-stainless steels.
- Never add MEKP to anything that is hot, since explosive decomposition may result.
- Avoid contact with skin, eyes, and clothing. Protective equipment should be worn at all times. During clean-up of spilled MEKP, personal safety equipment, gloves, and eye protection must be worn. Firefighting equipment should be at hand and ready.
- Avoid spillage, which can heat up to the point of self-ignition.
- Repair any leaks discovered in the catalyst system immediately, and clean-up the leaked catalyst at once in accordance with the catalyst manufacturer's instructions.
- Use only original equipment or equivalent parts from Magnum Venus Products in the catalyst system (i.e.: hoses, fitting, etc.) because a dangerous chemical reaction may result between substituted parts and MEKP.
- Catalyst accumulated from the purging of hoses or the measurement of fluid output deliveries should never be returned to the supply tank, such catalyst should be diluted with copious quantities of clean water and disposed of in accordance with the catalyst manufacturer's instructions.

The extent to which the user is successful in accomplishing these ends and any additional recommendations by the catalyst manufacturer determines largely the safety that will be present in his operation.

Clean-Up Solvents and Resin Diluents



WARNING

A hazardous situation may be present in your pressurized fluid system! Hydro carbon solvents can cause an explosion when used with aluminum or galvanized components in a closed (pressurized) fluid system (pump, heaters, filters, valves, spray guns, tanks, etc.). An explosion could cause serious injury, death, and/or substantial property damage. Cleaning agents, coatings, paints, etc. may contain Halogenated Hydrocarbon solvents. Some Magnum Venus Products spray equipment includes aluminum or galvanized components and will be affected by Halogenated Hydrocarbon solvents.

There are three key elements to the Halogenated Hydrocarbon (HHC) solvent hazard.

- | | | |
|----|---|---|
| 1. | The presence of HHC solvents. | 1,1,1 – Trichloroethane and Methylene Chloride are the most common of these solvents. However, other HHC solvents are suspect if used; either as part of paint or adhesives formulation, or for clean-up flushing. |
| 2. | Aluminum or Galvanized Parts. | Most handling equipment contains these elements. In contact with these metals, HHC solvents could generate a corrosive reaction of a catalytic nature. |
| 3. | Equipment capable of withstanding pressure. | When HHC solvent contact aluminum or galvanized parts inside a closed container such as a pump, spray gun, or fluid handling system, the chemical reaction can, over time, result in a build-up of heat and pressure, which can reach explosive proportions. When all three |

elements are present, the result can be an extremely violent explosion. The reaction can be sustained with very little aluminum or galvanized metal; any amount of aluminum is too much.

- The reaction is unpredictable. Prior use of an HHC solvent without incident (corrosion or explosion) does NOT mean that such use is safe. These solvents can be dangerous alone (as a clean-up or flushing agent) or when used as a component or a coating material. There is no known inhibitor that is effective under all circumstances. Mixing HHC solvents with other materials or solvents such as MEKP, alcohol, or toluene may render the inhibitors ineffective.
- The use of reclaimed solvents is particularly hazardous. Reclaimers may not add any inhibitors. The possible presence of water in reclaimed solvents could also feed the reaction.
- Anodized or other oxide coatings cannot be relied upon to prevent the explosive reaction. Such coatings can be worn, cracked, scratched, or too thin to prevent contact. There is no known way to make oxide coatings or to employ aluminum alloys to safely prevent the chemical reaction under all circumstances.
- Several solvent suppliers have recently begun promoting HHC solvents for use in coating systems. The increasing use of HHC solvents is increasing the risk. Because of their exemption from many state implementation plans as Volatile Organic Compounds (VOCs), their low flammability hazard, and their not being classified as toxic or carcinogenic substances, HHC solvents are very desirable in many respects.



WARNING

Do not use Halogenated Hydrocarbon (HHC) solvents in pressurized fluid systems having aluminum or galvanized wetted parts. Magnum Venus Products is aware of NO stabilizers available to prevent HHC solvents from reaction under all conditions with aluminum components in closed fluid systems. HHC solvents are dangerous when used with aluminum components in a closed fluid system.

- Consult your material supplier to determine whether your solvent or coating contains Halogenated Hydrocarbon solvents.
- Magnum Venus Products recommends that you contact your solvent supplier regarding the best non-flammable clean-up solvent with the heat toxicity for your application.
- If, however, you find it necessary to use flammable solvents, they must be kept in approved, electrically grounded containers.
- Bulk solvent should be stored in a well-ventilated, separate building, 50 feet away from your main plant.
- You should only allow enough solvent for one day's use in your laminating area.
- NO SMOKING signs must be posted and observed in all areas of storage or where solvents and other flammable materials are used.
- Adequate ventilation (as covered in OSHA Section 1910.94 and NFPA No.91) is important wherever solvents are stored or used, to minimize, confine and exhaust the solvent vapors.
- Solvents should be handled in accordance with OSHA Section 1910.106 and 1910.107.

Catalyst Diluents

Magnum Venus Products spray-up and gel-coat systems currently produced are designed so that catalyst diluents are not required. Magnum Venus Products therefore recommends that diluents not be used to avoid possible contamination which could lead to an explosion due to the handling and mixing of MEKP and diluents. In addition, it eliminates any problems from the diluent being contaminated through rust particles in drums, poor quality control on the part of the diluents suppliers, or any other reason. If diluents are absolutely required, contact your catalyst supplier and follow his instructions explicitly. Preferably the supplier should premix the catalyst to prevent possible “on the job” contamination while mixing.



WARNING

If diluents are not used, remember that catalyst spillage and gun, hose, and packing leaks are potentially more hazardous since each drop contains a higher concentration of catalyst and will therefore react more quickly with overspray and the leak.

Cured Laminate, Overspray and Laminate Sandings Accumulation

- Remove all accumulations of overspray, Fiberglass Reinforced Plastic (FRP) sandings, etc. from the building as they occur. If this waste is allowed to build up, spillage of catalyst is more likely to start a fire; in addition, the fire would burn hotter and longer.
- Floor coverings, if used, should be non-combustible.
- Spilled or leaked catalyst may cause a fire if it comes in contact with an FRP product, oversprayed chop or resin, FRP sandings or any other material with MEKP.

To prevent spillage and leakage, you should:

- | | |
|--|---|
| 1. Maintain your Magnum Venus Products System. | Check the gun several times daily for catalyst and resin packing or valve leaks. REPAIR ALL LEAKS IMMEDIATELY. |
| 2. Never leave the gun hanging over or lying inside the mold. | A catalyst leak in this situation would certainly damage the part, possibly the mold, and may cause a fire. |
| 3. Inspect resin and catalyst hoses daily for wear or stress at the entry and exits of the boom sections and at the hose and fittings. | Replace if wear or weakness is evident or suspected. |
| 4. Arrange the hoses and fiberglass roving guides so that the fiberglass strands DO NOT rub against any of the hoses at any point. | If allowed to rub, the hose will be cut through, causing a hazardous leakage of material which could increase the danger of fire. Also, the material may spew onto personnel in the area. |

Toxicity of Chemicals

- Magnum Venus Products recommends that you consult OSHA Sections 1910.94, 1910.106, 1910.107 and NFPA No.33, Chapter 14, and NFPA No.91.
- Contact your chemical supplier(s) and determine the toxicity of the various chemicals used as well as the best methods to prevent injury, irritation and danger to personnel.

- Also determine the best methods of first aid treatment for each chemical used in your plant.

Equipment Safety

Magnum Venus Products suggest that personal safety equipment such as EYE GOGGLES, GLOVES, EAR PROTECTION, and RESPIRATORS be worn when servicing or operating this equipment. Ear protection should be worn when operating a fiberglass chopper to protect against hearing loss since noise levels can be as high as 116 dB (decibels). This equipment should only be operated or serviced by technically trained personnel!



CAUTION

Never place fingers, hands, or any body part near or directly in front of the spray gun fluid tip. The force of the liquid as it exits the spray tip can cause serious injury by shooting liquid through the skin. NEVER LOOK DIRECTLY INTO THE GUN SPRAY TIP OR POINT THE GUN AT OR NEAR ANOTHER PERSON OR AN ANIMAL.



DANGER

Contaminated catalyst may cause fire or explosion. Before working on the catalyst pump or catalyst accumulator, wash hands and tools thoroughly. Be sure work area is free from dirt, grease, or resin. Clean catalyst system components with clean water daily.



DANGER

Eye, skin, and respiration hazard. The catalyst MEKP may cause blindness, skin irritation, or breathing difficulty. Keep hands away from face. Keep food and drink away from work area.

Treatment of Chemical Injuries



CAUTION

Refer to your catalyst manufacturer's safety information regarding the safe handling and storage of catalyst. Wear appropriate safety equipment as recommended.

Great care should be used in handling the chemicals (resins, catalyst and solvents) used in polyester systems. Such chemicals should be treated as if they hurt your skin and eyes and as if they are poison to your body. For this reason, Magnum Venus Products recommends the use of protective clothing and eye wear in using polyester systems. However, users should be prepared in the event of such an injury.

Precautions include:

Know precisely what chemicals you are using and obtain information from your chemical supplier on what to do in the event the chemical gets onto your skin or into the eyes, or if swallowed.

Keep this information together and easily available so that it may be used by those administering first aid or treating the injured person.

Be sure the information from your chemical supplier includes instructions on how to treat any toxic effects the chemicals have.



WARNING

Contact your doctor immediately in the event of an injury. If the product's MSDS includes first aid instructions, administer first aid immediately after contacting a doctor.

Fast treatment of the outer skin and eyes that contact chemicals generally includes immediate and thorough washing of the exposed skin and immediate and continuous flushing of the eyes with lots of clean water for at least 15 minutes or more. These general instructions of first aid treatment may be incorrect for some chemicals; you must know the chemicals and treatment before an accident occurs. Treatment for swallowing a chemical frequently depends upon the nature of the chemical.

Emergency Stop Procedure

In an emergency, follow these steps to stop a system:

1. The ball valve located where the air enters the power head of the resin pump, should be moved to the "OFF" or closed position.

Note ***The "open" or "on" position is when the ball valve handle is parallel (in line) with the ball valve body. The "closed" or "off" position is when the ball valve handle is perpendicular (across) the ball valve body.***

2. Turn all system regulators to the "OFF" position (counter-clockwise) position.
3. Verify / secure the catalyst relief line, located on the catalyst relief valve.
4. Verify / secure the resin return line, located on the resin filter.
5. Place a container under the resin pump ball valve to catch ejected resin.
6. Locate the ball valve on the resin pump.
7. Rotate the ball valve 90 degrees to the "On" or open position.

Grounding

Grounding an object means providing an adequate path for the flow of the electrical charge from the object to the ground. An adequate path is one that permits charge to flow from the object fast enough that it will not accumulate to the extent that a spark can be formed. It is not possible to define exactly what will be an adequate path under all conditions since it depends on many variables. In any event, the grounding means should have the lowest possible electrical resistance.

Grounding straps should be installed on all loose conductive objects in the spraying area. This includes material containers and equipment. Magnum Venus Products recommends grounding straps be made of AWG No.18 stranded wire as a minimum and the larger wire be used where possible. NFPA Bulletin No77 states that the electrical resistance of such a leakage path should be 1 meg ohm (10^6 ohms) or less.

**CAUTION**

Whenever flammable or combustible liquids are transferred from one container to another, or from one container to the equipment, both containers or container and equipment shall be effectively bonded and grounded to dissipate static electricity. For further information, see National Fire Protection Association (NFPA) 77, titled “Recommended Practice on Static Electrical”. Refer especially to section 7-7 titled “Spray Application of Flammable and Combustible Materials”.

Introduction

This manual provides information for the operation, maintenance, and simple repair of the MVP Patriot Pro Innovator 2. The following procedures are included:

- Step-by-step assembly and disassembly
- Installation, start-up, and shut-down instructions
- Step-by-step operation instructions



Please read this manual carefully and retain for future reference. Follow the steps in the order given, otherwise you may damage the equipment or injure yourself.

Component Assemblies

MVP’s Patriot Pro Innovator 2 consists of multiple components. Each component has its own detailed manual and drawings. For complete repair and maintenance instructions, refer to the appropriate manuals.

- AUTO PRO GUN REPAIR MANUAL – PRTM-DG-3000-A (**INJECTION GUN**)
- 1:1 CLASSIC PRO GUN REPAIR MANUAL – PRTM-RG-1000-A (**RECIRCULATION GUN**)
- PATRIOT POWERHEAD MANUAL
- PATRIOT 1-1/4 FLUID SECTION MANUAL
- PATRIOT METERING PUMP MANUAL
- INNOVATOR II MANUAL (**CONTROL BOX**)

Note **See the Innovator II Control Box Manual for a detailed list of part number and instructions for operating the Innovator II Control Box.**

Air Requirements

1. The system requires a supply of air (30 cfm) and at least 100 psi (7 bar).
2. The unit requires a ½ inch (12 - 13 mm) inside diameter air hose minimum (use caution when using quick disconnects; they may restrict air flow).
3. Preferably the air will be clean, dry, and oil free.

Unit Overview

Below helps identify the main components the operator needs to know for proper operation for the unit.

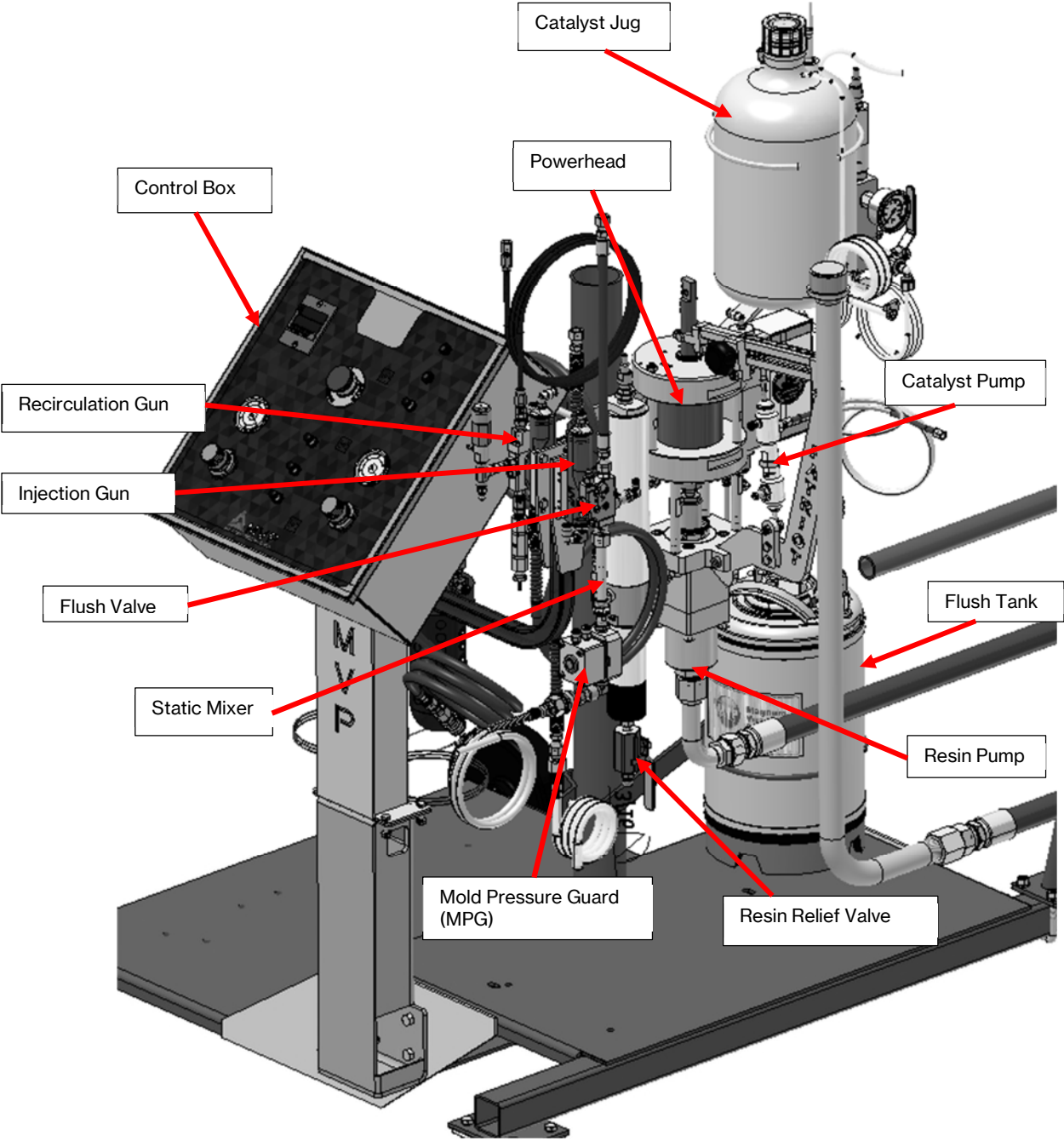

Unit Overview, continued

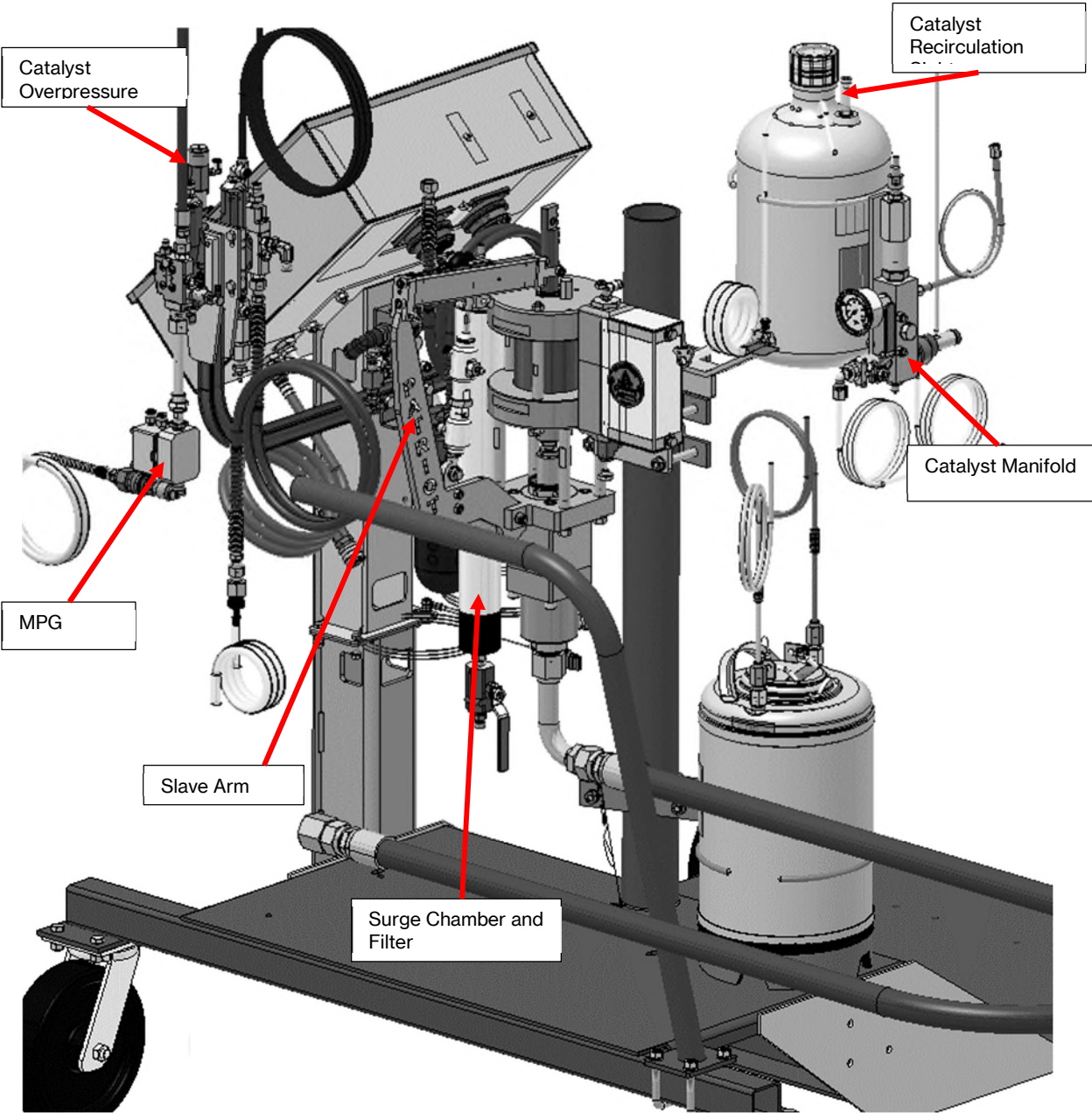

Overview of Controls

Following is a brief description of the main controls and their function. For full instructions on programming and troubleshooting the control box, see the “Innovator 2 Control Unit Component Manual”.

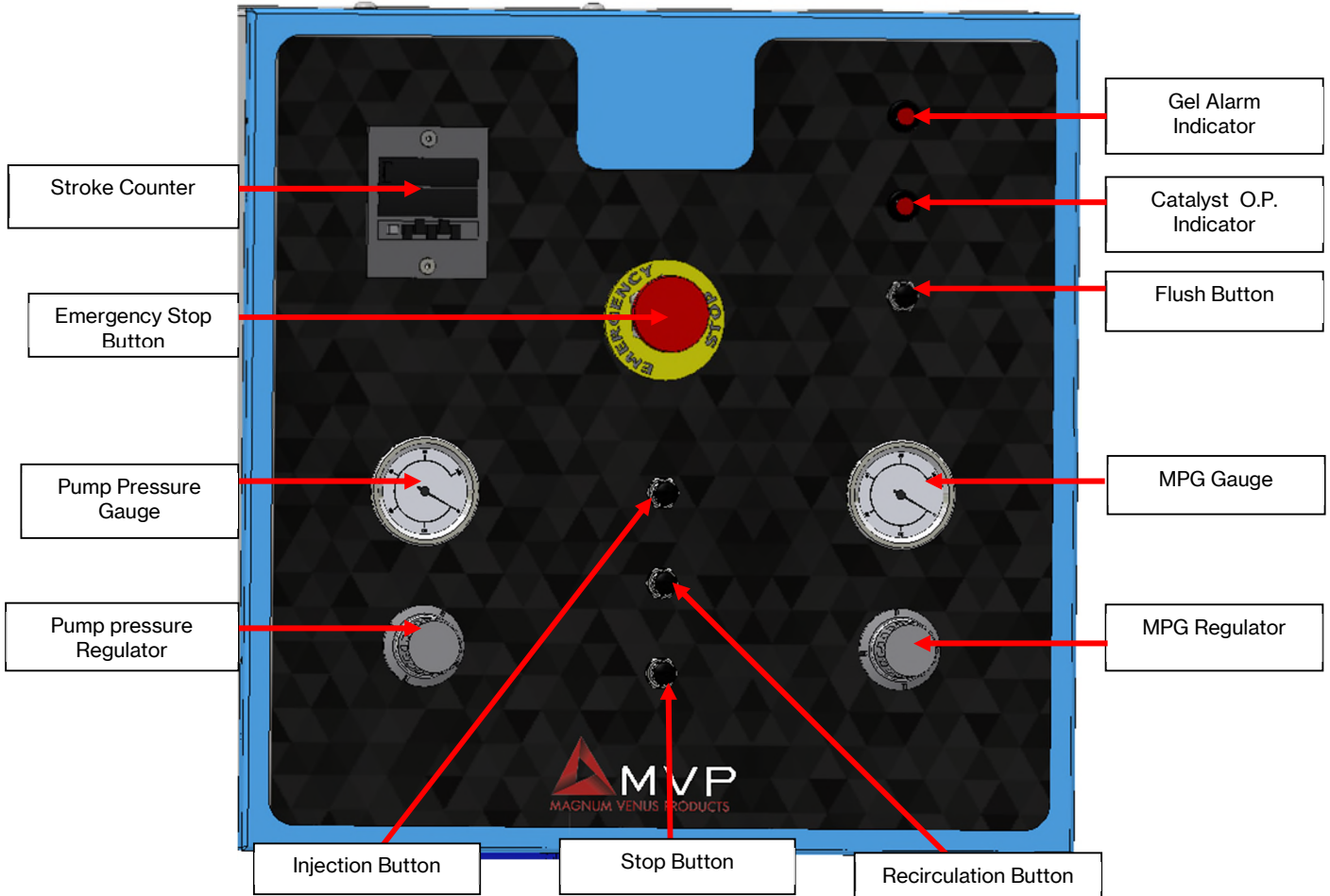

Innovator 2 Control Panel		
Control Name	Type of Control	Function
Emergency Stop	Push Button	Press this button in the event of an emergency to place the system in a safe state. Twist and pull to release and allow machine operation.
Pump Pressure	Pressure Gauge	Displays the air pressure being supplied to the pump.
Pump Pressure	Regulator	Adjust this to control the air pressure being supplied to the pump and to set the pump speed.
CAT/OP	Indicator Light	Will turn red if overpressure state exists.
RGA Alarm	Indicator Light	Will turn red if gel alarm timer has expired.
Flush Button	Push Button	Press this button to operate the flush cycle

Innovator 2 Control Panel		
Control Name	Type of Control	Function
Mold Pressure Guard	Preset Level Gauge	Displays signal air pressure being supplied to the Mold Pressure Guard (MPG) control.
Mold Pressure Guard	Regulator	Use this to adjust the MPG control signal air pressure.
Inject Button	Push Button	Press this button to start the machine in inject mode.
Recirculate Button	Push Button	Press this button to start the machine in recirculation mode.
Stop Button	Push Button	Press this button to stop the machine in injection, recirculation, or flush mode.
Stroke Count	Counter	Displays the current number of strokes the pump has performed.
Stroke Count Preset Count	Counter	Displays the number of strokes at which the unit will shut down when reached.
Stroke Count Digit Modifiers	Spin Buttons	Click up or down to adjust the number in the Preset Count column to set the stroke count the machine should stop at.
Digit Lockout	Button	Press this button to keep the stroke count setting.
Reset Button	Push Button	Press this button to reset the current stroke count.

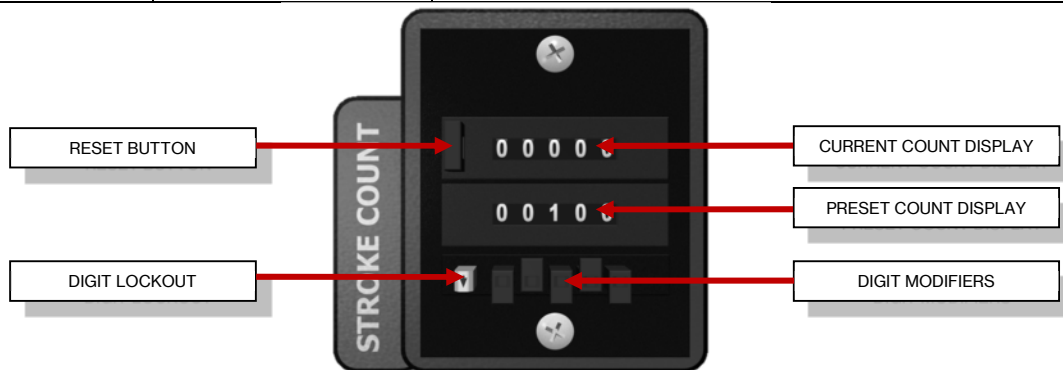

Back of Control Box

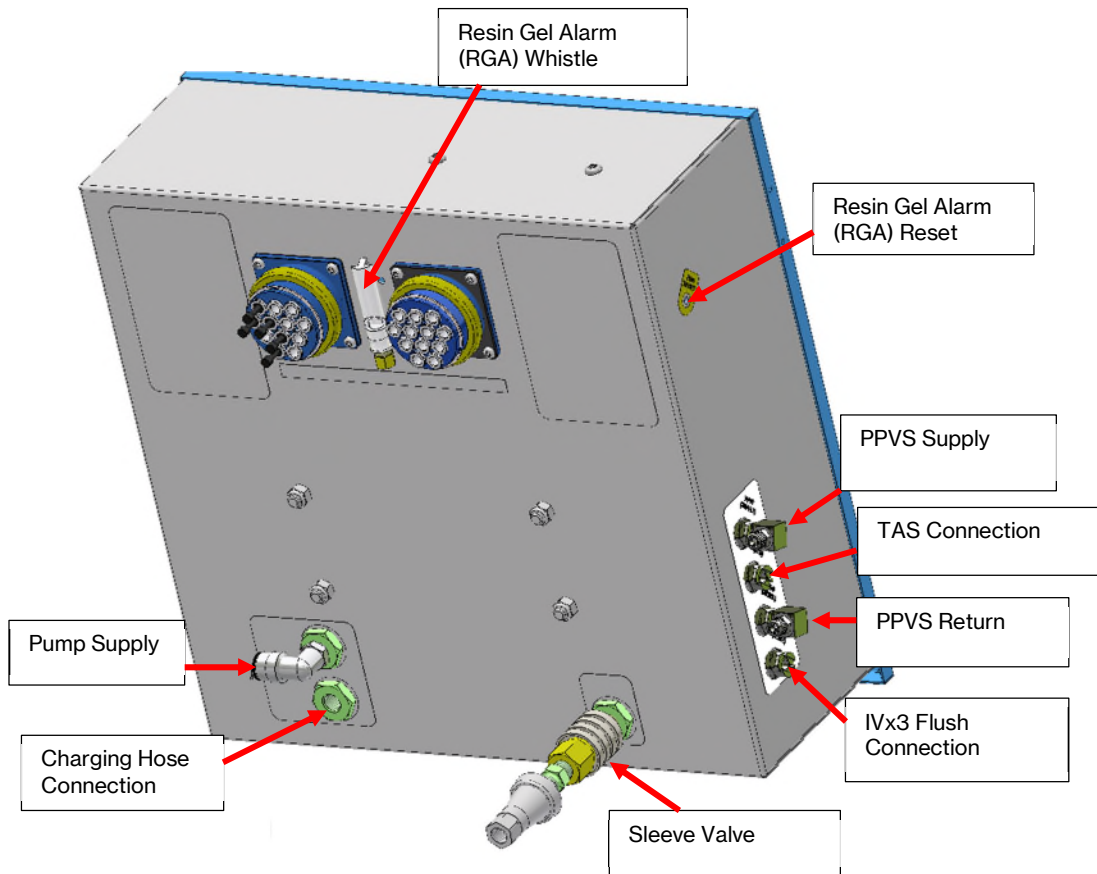

Innovator 2 Control Panel – Side

Control Name	Type of Control	Function
RGA Rest	Recessed button	Can be pressed by inserting a small screwdriver or equivalent into the hole. This is not intended to be used in normal operation and is provided as a means to silence the alarm if the pump cannot run and machine cannot be flushed.
PPVS Supply	Signal connection	Use this to connect to a Pneumatic Pressure Vacuum Sensor (PPVS)
TAS (RTM only)	Signal connection	Use this to connect to a Turbo Autosprue (TAS) or similar valve. This line becomes active when the injection cycle is initiated.
PPVS Signal	Signal connection	Return signal from the PPVS when used. Once this port receives a signal the pump stops Note <i>There must be a signal present on the PPVS signal for the machine to inject. If no PPVS is used, install the supplied jumper between the PPVS supply and PPVS signal for the machine to function.</i>

Innovator 2 Control Panel – Side		
Control Name	Type of Control	Function
IVx3 Flush	Signal connection	When the flush cycle is initiated, this moves the IVx3 valve into the flush position. This line remains active until the next injection cycle starts.

Adjusting Settings

The user can adjust the flush timer duration, the MPG response time, the RGA stroke timer, and the alarm volume by changing the settings of components inside the control box. Refer to the circuit diagram and component labels for assistance in identifying the items that need adjustment.

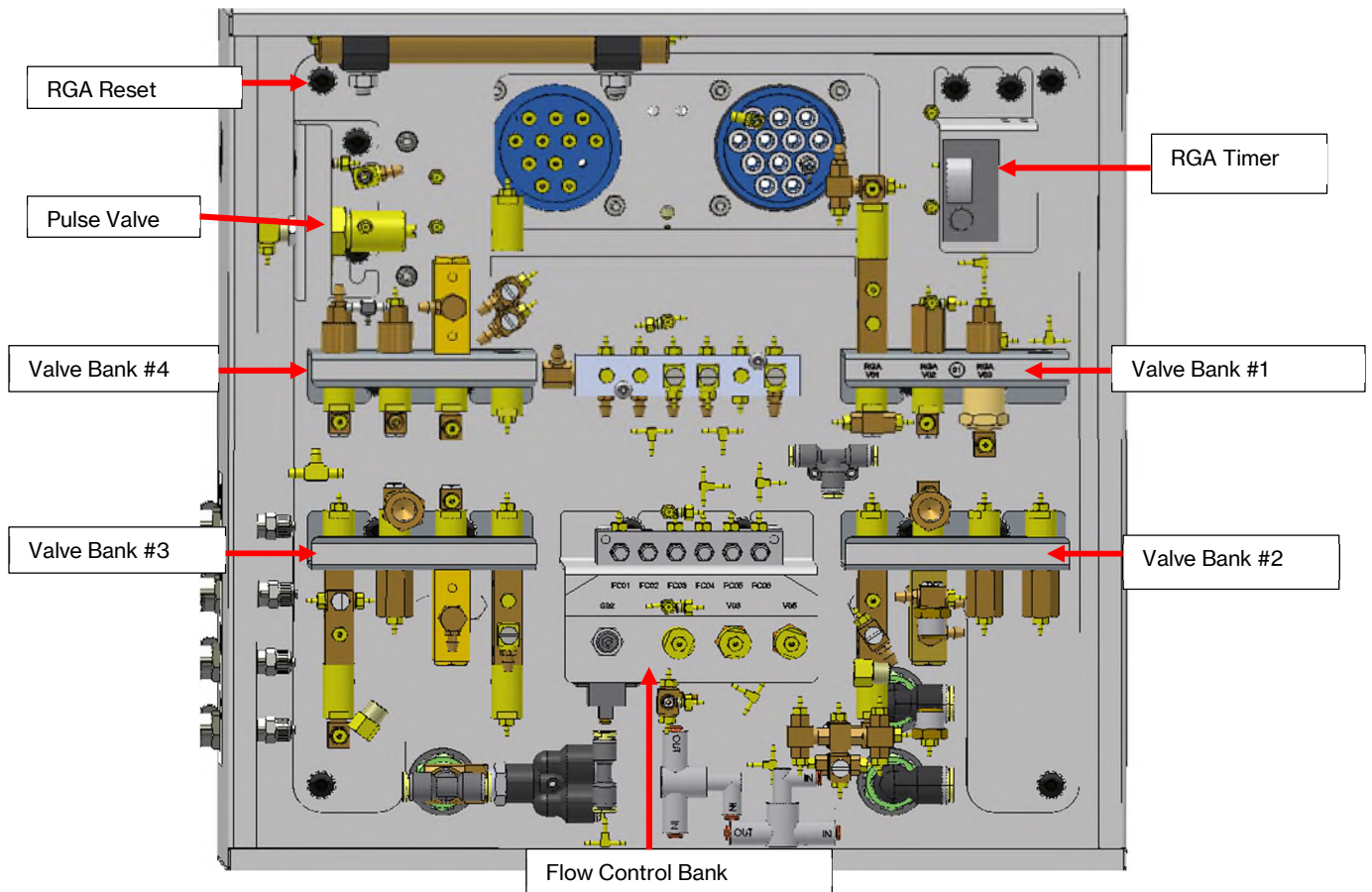

To adjust the settings, follow these steps:

Resin Gel Alarm (RGA)

1. Turn the knob on the mechanical RGA timer to set the required time (between 20 and 300 seconds).

Note ***The dial shows seconds divided by 10. Therefore to set 100 seconds, set the dial to 10.***

- To adjust the pneumatic RGA control, turn the knob on the flow control bank marked FC03.

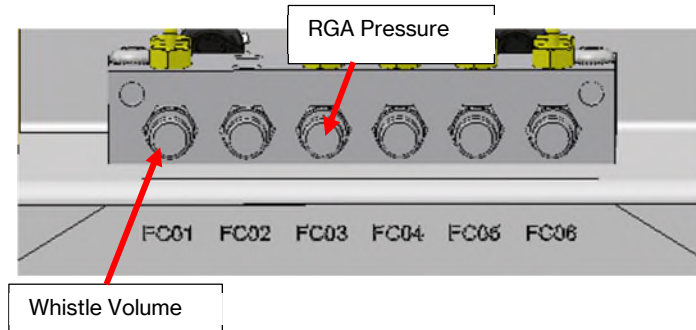

- To adjust the whistle volume, turn the flow control knob that is marked FC01 (inline with the whistle).

Flush Timer

- Turn the knob marked FC05 (flush timer restrictor) to adjust the flush timer.

Note ***This circuit controls the rate of airflow out of the timer circuit reservoir and the speed at which the pressure fall in order to actuate the automatic flush stop valve. If the restrictor is fully wound in, air flow will be blocked and the timer will not operate.***

- Time the flush cycle, then adjust the knob to increase or decrease the time as needed.
- Repeat these steps until the desired flush time is achieved.

Note ***Times over 60 seconds are achievable with this circuit.***

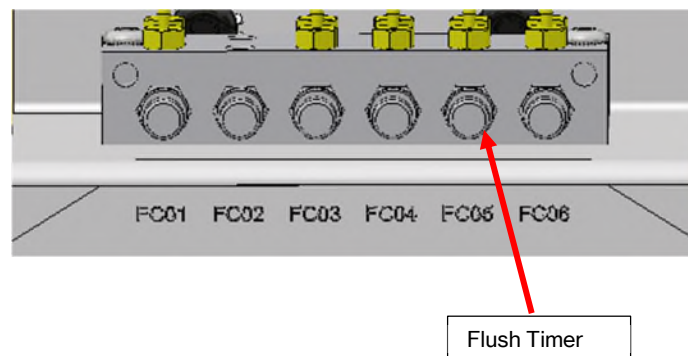

Mold Pressure Guard (MPG)

The machine features a Mold Pressure Guard (MPG), which is used to control the maximum allowable pressure at the mixing head. The MPG can be used to provide line pressure control during an injection or as a safety mechanism to prevent the line pressure from exceeding the maximum working pressure of the injection line to the mold.

The MPG block is supplied with 2 air lines. One air-line supplies air from the MPG pressure regulator on the control panel. The other is connected to an internal circuit on the control box.

When fluid pressure at the injection head exceeds the MPG preset level shown on the MPG pressure gauge, the internal diaphragm moves the MPG piston outward and leaks air from the line connected to the control circuit.

As the level/flow of air pressure is reduced by the MPG piloted regulator, the supply pressure to the pump is reduced, in effect slowing it down. Once the air pressure in the control circuit has dropped below approximately 15 psi, the pump will shut off. Once the pressure has been restored, whether by fluid being drawn into the mold, recirculation engage, or blockage cleared from output line, the system will start up again.

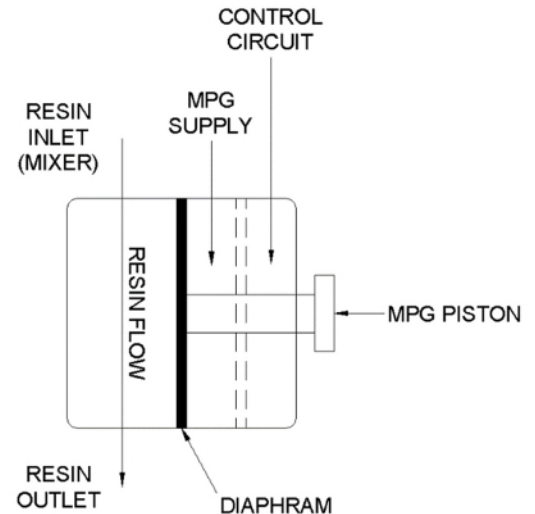

Note ***The MPG control is active in recirculation or injection mode. It is normal to hear air leaking from the MPG block when the MPG is operational.***

- Adjust the MPG settings by turning the knob marked FC06.

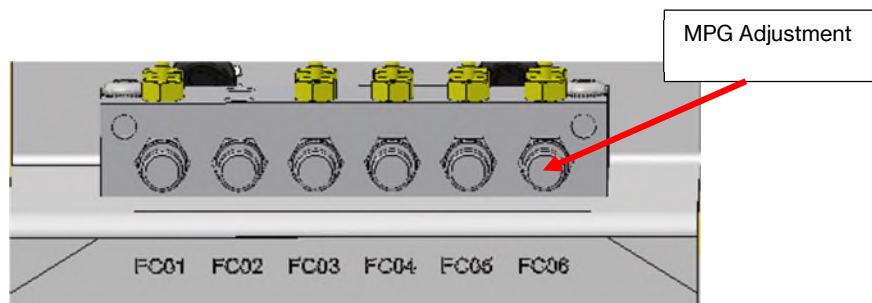

Note ***The slower the flow of air through the restrictor, the longer the pump will take to restart. If the restrictor is fully wound in, airflow will be blocked and the pump will not start. Conversely, if too higher flow of air is supplied to the circuit, safe and correct operation of the machine cannot be guaranteed. This flow control is set at factory and should not be adjusted unless absolutely necessary.***

Note ***The response of the pump can be further slowed if required by the addition of an air reservoir on the circuit. Contact MVP for more information.***

Catalyst Overpressure

The catalyst overpressure (Cat O/P) restrictor controls the rate at which air is supplied to the bleed control circuit. When the cat O/P leaks more air than can be supplied through this restrictor, the pressure in the circuit falls and the pump stops. When the circuit is sealed once again, the restrictor controls how quickly the pressure builds within the circuit and therefore the time and speed which it takes the pump to restart. The slower the flow of air, the longer the pump will take to restart.

- Turn the knob marked FC04 to adjust the catalyst overpressure speed.

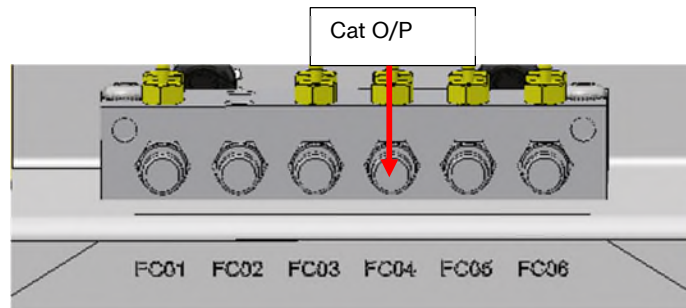

Note *If the restrictor is fully wound in, airflow will be blocked and the pump will not start. Conversely, if too higher flow of air is supplied to the circuit, safe and correct operation of the machine cannot be guaranteed. This flow control is set at factory and should not be adjusted unless absolutely necessary.*

Getting Started



CAUTION

Always put on respirator as specified for spray painting and all personal protective equipment/clothing recommended by the Material Safety Data Sheets (MSDS) of your material manufacturer(s).

- Have all tools and materials needed for pre-start checks available.
- Connect an appropriate air supply to the main air inlet.
- Slide the air valve on the back of the control cabinet to the open position.
- Twist and pump the emergency stop button to allow machine operation.
- Check all catalyst and resin fittings to be sure they are tight.
- Fill the resin pump packing nut cavity $\frac{1}{3}$ full with TSL oil or equivalent.
- Press the **Injection** button and check that the injection gun valve rotates open.
- Press the **Stop** button.
- Tighten both the packing nuts on the injection gun block.
- Repeat steps 7 - 9 three times to set the packing in the gun block.

11. Press the **Recirculate** button and check that the recirculation gun valve rotates open.
12. Press the **Stop** button.
13. Tighten both the packing nuts on the recirculation gun block.
14. Repeat steps [11](#) - [13](#) three times to set the packing in the gun block.
15. Fill the catalyst jug at least $\frac{1}{2}$ full of catalyst.
16. Secure the pick-up wand to the pump inlet.
17. Place the resin pick-up wand in the resin supply container.
18. Place the end of the resin return hose in the resin container.
19. Fill the flush tank at least $\frac{3}{4}$ full of appropriate solvent.
20. Place an appropriate container under the injection head and test the flush system by pressing the flush button.

First Time Start Up

21. Turn the pump regulator to zero.
22. Adjust the catalyst percentage as required.
23. With all material containers properly filled, press the **Recirculation** button on the control panel.
24. Slowly increase the pump pressure regulator so that the pump strokes slowly and evenly.
25. Allow the pump to recirculate until the flow of resin and catalyst back to their respective containers is free of bubbles.
26. Press the **Stop** button to take the unit out of recirculation mode.
27. Follow the steps in the Performing a Gel Test section before first use.

Performing a Gel Test

1. Check all material supplies and refill or replace as needed.
2. Open the main air supply slide valve on the back of the control panel.
3. Press the recirculation button and allow the unit to recirculate for at least 20 strokes or until no bubbles are seen returning to the catalyst jug from the recirculation tube.
4. Check that the catalyst percentage is set properly.
5. Check the resin pump pressure and adjust as necessary.
6. Press the **Stop** button to take the unit out of recirculation mode.
7. Connect a short feed hose to the outlet of the injection head.
8. Place the feed hose over an appropriate container to catch extra resin.
9. Press the **Injection** button.
10. After one or two strokes of the pump, quickly move a graduated container under the resin stream to catch about 100 grams of resin.

11. Repeat step [10](#) until you have obtained two or three more samples, then press the **Stop** button.
12. Flush the injection head as necessary.
13. Mark the sample containers with the relevant test information, including time, catalyst percentage, resin temperature, and operator.
14. Press the reset button on the counter to set the count back to zero.

Performing Daily Tasks

Daily Start Up

1. Check all hoses for leaks or damage; replace as needed.
2. Check all material supplies and refill or replace as needed.

Note ***Never allow catalyst or resin to run out during an injection.***

3. Open the main air supply slide valve on the back of the control panel.
4. Press the recirculation button and allow the unit to recirculate for at least 20 strokes or until no bubbles are visible returning to the catalyst jug from the recirculation tube.
5. Check that the catalyst percentage is set properly.
6. Check the resin pump pressure and adjust as needed.
7. Set the desired number of counts on the stroke counter display.
8. Make sure the catalyst pressure gauge reads above 115 to 145 psi (8 to 10 bar) before beginning the injection.
9. Press the **Stop** button to take the unit out of recirculation mode.
10. Perform a gel test each morning and balance the fluid pressures by following the steps in the Performing a Gel Test section.
11. Connect the injection hoses from the injection head to the IVx3 valves.
12. Make sure the flush hose from the IVx3 valves are connected to the flush tank.
13. Make sure the IVx3 valve and PPVS are properly connected to the control box and working correctly (the PPVS should open the IVx3 valve when there is enough vacuum under the membrane).

The unit is ready for injection.

Daily Shut Down

The preset counter will stop the injection when the set count is reached.

14. If you need to complete the injection before the preset count is reached, press the **Stop** button to close the injection head.
15. Press the reset button on the counter.

16. Flush the injection head, feed hose(s), IVx3, TAS, or other resin valves used.
17. Disconnect the resin feed hose from the injection head.
18. If you need to inject another mold, return to the Daily Start Up instructions.
19. If you need to shut down for the day, press the recirculation button and allow the unit to recirculate for about one minute.
20. Press the **Stop** button.
21. Turn off the main air slide valve on the back.

Maintenance

Refer to the applicable component manuals for recommended maintenance and repair procedures for the fluid section, catalyst pump, powerhead, injection gun and mixer, and recirculation gun.

For other major components, follow the guidelines below.

SP4 Solvent Pump

The SP4 Solvent Pump assembly performs a 200-cc solvent purge followed by an air purge to thoroughly clean and purge the injection head and mixer. It is contained within the flush tank. During the flush cycle, only the SP4 solvent pump will be pressurized to force out the solvent contained inside and then purges air for the remainder of the flush cycle.

There are two connection to the flush pump inside the flush tank:

- The pump inlet air tube connects to the inlet side of the SP4 solvent pump through the inlet fitting
- The yellow flush tube from the injection gun/mix head extends down through the outlet side fitting and connects to the outlet of the solvent pump

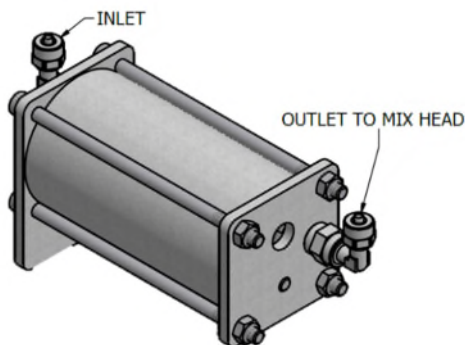

Note *It is important that the solvent level in the tank remain no less than $\frac{1}{3}$ full so there is at least one inch of solvent above the pump. This will allow the pump to properly refill with solvent after each use.*

Activate the SP4 by pressing the flush button on the control panel. The pump will operate for 30 to 60 seconds. The duration of the flush/purge cycle can be adjusted. For more information, reference the Innovator II Control Unit component manual.

Maintenance

It is important to keep the inside of the flush tank clean and free of dirt, debris, or glass fiber. These can prevent the pump foot valve from sealing properly.

The SP4 solvent pump is essentially maintenance free except it will occasionally be necessary to replace the O-ring on the pump foot valve.

Troubleshooting

System Troubleshooting		
Symptom	Possible Cause	Remedy
Will not start injection or has stopped during injection sequence	Insufficient air supply	Apply correct pressure and CFM to unit
	Stop button pushed	Press Inject button
	Remote stop button pushed	Restart injection sequence
	PPVS signal not being received	Install jumper between PPVS supply and PPVS signal if no PPVS is being used
	PPVS signal not being received	Check signal coming from PPVS if installed Check internal PPVS circuits: Check line (67) for leaks Check V08 output (41) for signal (should be on)
Will not start injection or has stopped during injection sequence		Check for blockage on resin delivery lines
		Check FC 03 for proper adjustment
Will not start injection or has stopped during injection sequence	MPG circuit is engaged	Check for air leaks on MPG valve and connection 1B-11 (26)
		Check internal MPG circuits <ul style="list-style-type: none"> • Check (26) for leaks • Check (67) for leaks • Check V14 output (62) for signal (should be on) • Check V15 output (05) for signal (should be on)
Will not start injection or has stopped during injection sequence	Stop sequence has been imitated	Check internal stop sequence circuits <ul style="list-style-type: none"> • Check (16) for signal (should be off) <ul style="list-style-type: none"> ○ Remote stop button has malfunctioned • Check (15) for signal (should be off) <ul style="list-style-type: none"> ○ CE NORM guard valve has malfunctioned • Check (37) for signal (should be off) <ul style="list-style-type: none"> ○ Pulse valve (S01) has malfunctioned. See below. • Check (39) for signal (should be off) <ul style="list-style-type: none"> ○ Pulse valve (S01) has malfunctioned. See below. • Check (49) for signal (should be off)

System Troubleshooting		
Symptom	Possible Cause	Remedy
		<ul style="list-style-type: none"> ○ Catalyst overpressure circuit engaged. See below. • Check (48) for signal (should be off) ○ Predetermined counter has not reset or has malfunctioned. See below.
	CE NORM guard has been opened	Close CE NORM guard and check valve for proper operation
	Pulse valve has malfunctioned	Check internal pulse valve circuit <ul style="list-style-type: none"> • Check (36) for signal (should be off) Note <i>This valve also resets all circuits to off when air pressure to the system is moved from an off state to on. If circuits are not resetting on startup this valve is faulty.</i>
	Catalyst overpressure circuit is engaged (indicated on control panel)	Check for blockage in catalyst system delivery lines Check FC 04 for proper adjustment Check for air leaks on catalyst overpressure valve and connection 1B-7(21) Check internal catalyst overpressure circuits <ul style="list-style-type: none"> • Check (21) for leaks • Check V03 output (49) for signal (should be off)
Predetermined counter not counting or skipping counts	Will not count in recirculation mode	Make sure unit is in injection mode
Predetermined counter not counting or skipping counts	FC 03 not adjusted properly	Adjust FC 03 for proper flow. See Innovator II Control Panel manual.
	Faulty signals from powerhead shift block	Repair or replace powerhead shift block
	Faulty RGA V03 valve or OR09 shuttle	Check (60) for signal. It should cycle on and off with pulses from powerhead.
	Faulty counter	Check (60) for signal. It should cycle on and off with pulse from powerhead.
Catalyst overpressure circuit does not stop pump	FC 04 not adjusted properly	Adjust flow control <ul style="list-style-type: none"> • Remove (21) from catalyst overpressure valve, start pump, then slowly turn FC 04 until pump stops
MPG will not stop pump on overpressure	Excessive pressure	Reduce MPG pressure from panel
	FC 04 not adjusted properly	Adjust flow control <ul style="list-style-type: none"> • Remove (26) from MPG valve, slowly turn in FC 06 until pump stops
Gel Alarm time incorrect	FC 03 not adjusted properly	Adjust flow control until gel alarm set correctly

System Troubleshooting		
Symptom	Possible Cause	Remedy
Gel Alarm not working	FC 03 not adjusted properly	Adjust flow control until gel alarm set correctly
		Check RGA V02 (51) for signal – should be off/pulsing when pumping and on when not pumping
		Check RGA V02 output (52) for signal – should be off/pulsing when pumping and on when not pumping
Flush dwell time incorrect	FC 05 not adjusted properly	Adjust flow control until flush dwell is set correctly
Flush not working	FC 05 not adjusted properly	Adjust flow control until flush dwell is set correctly

Pneumatic Diagrams

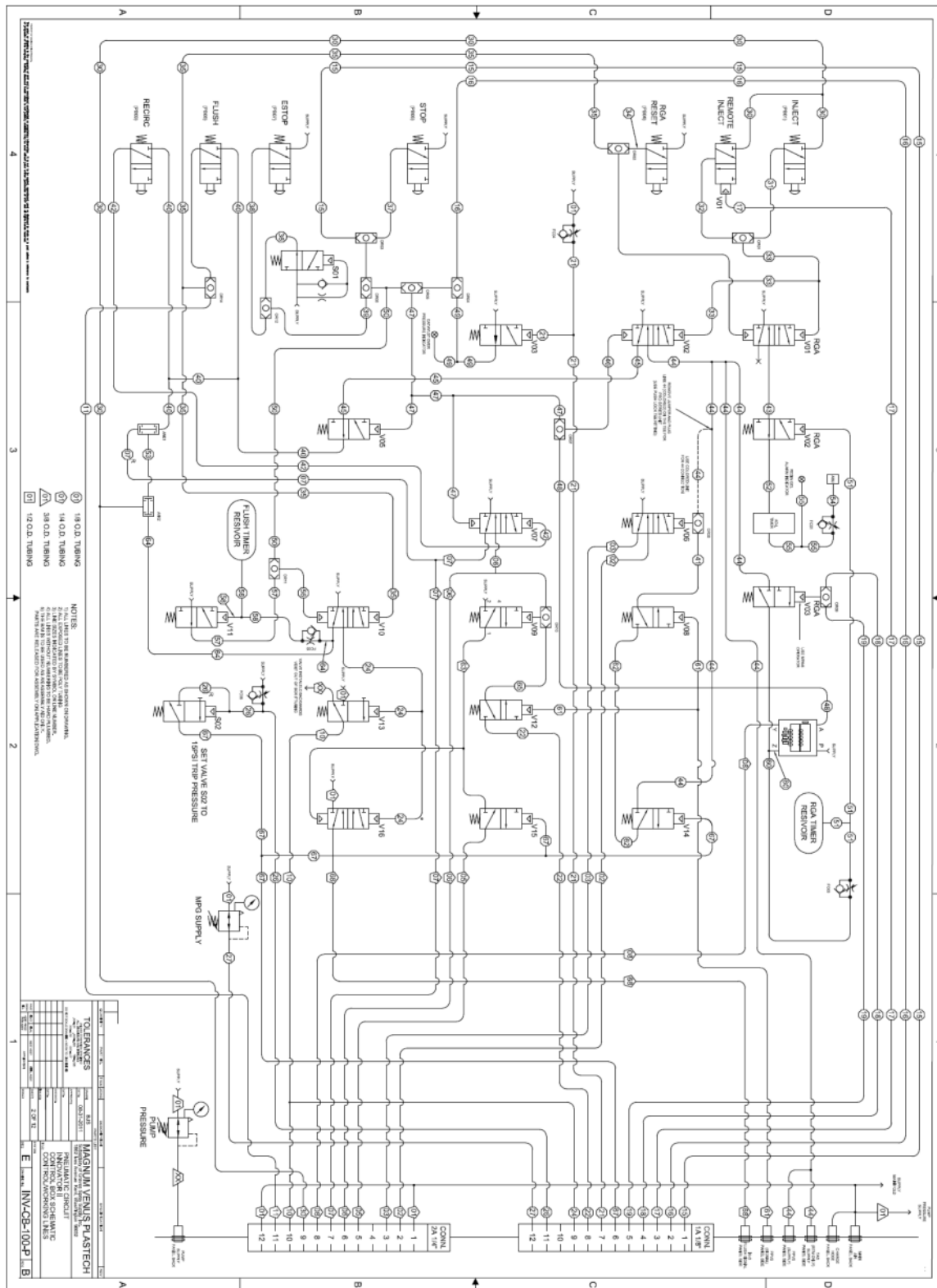

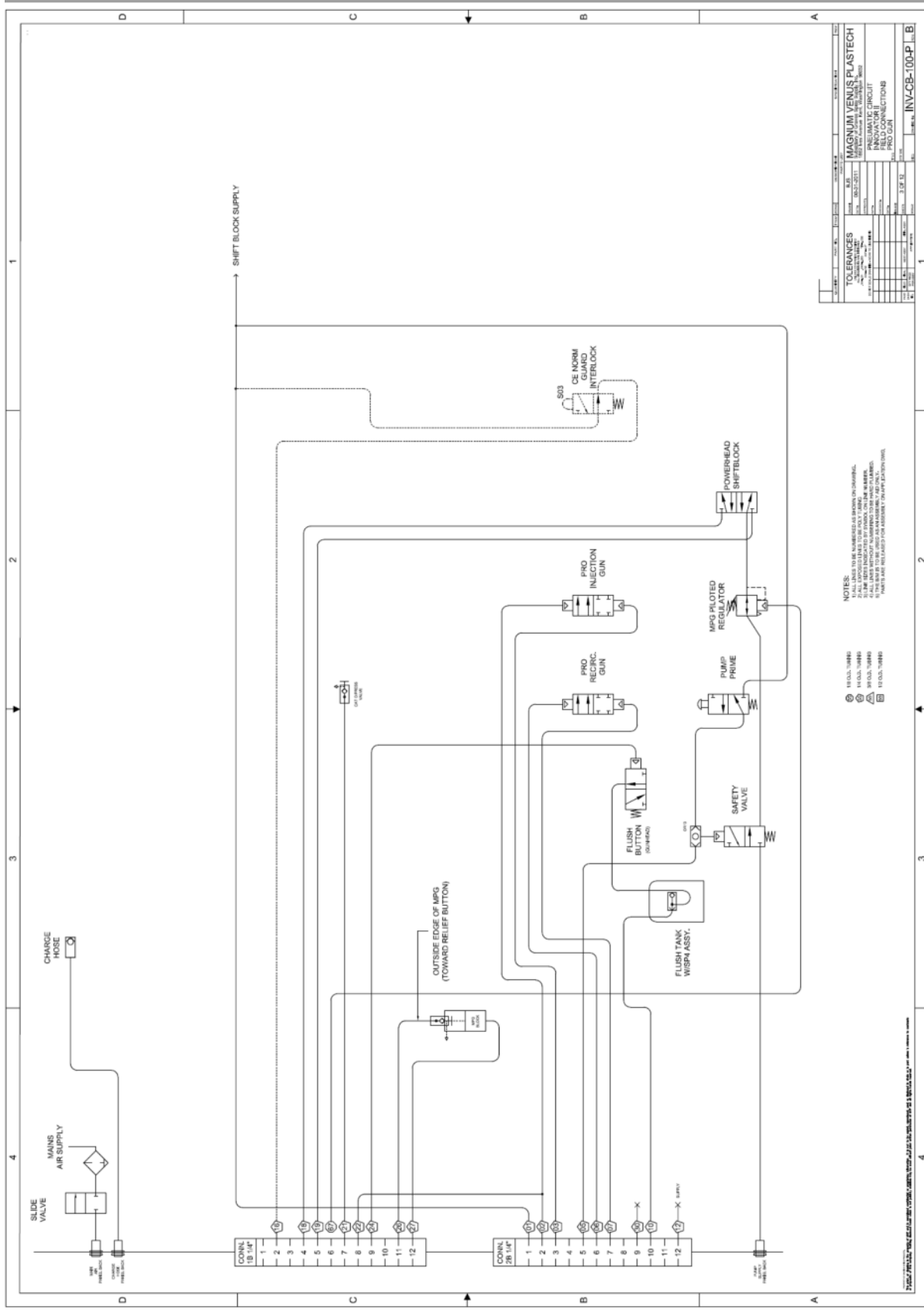

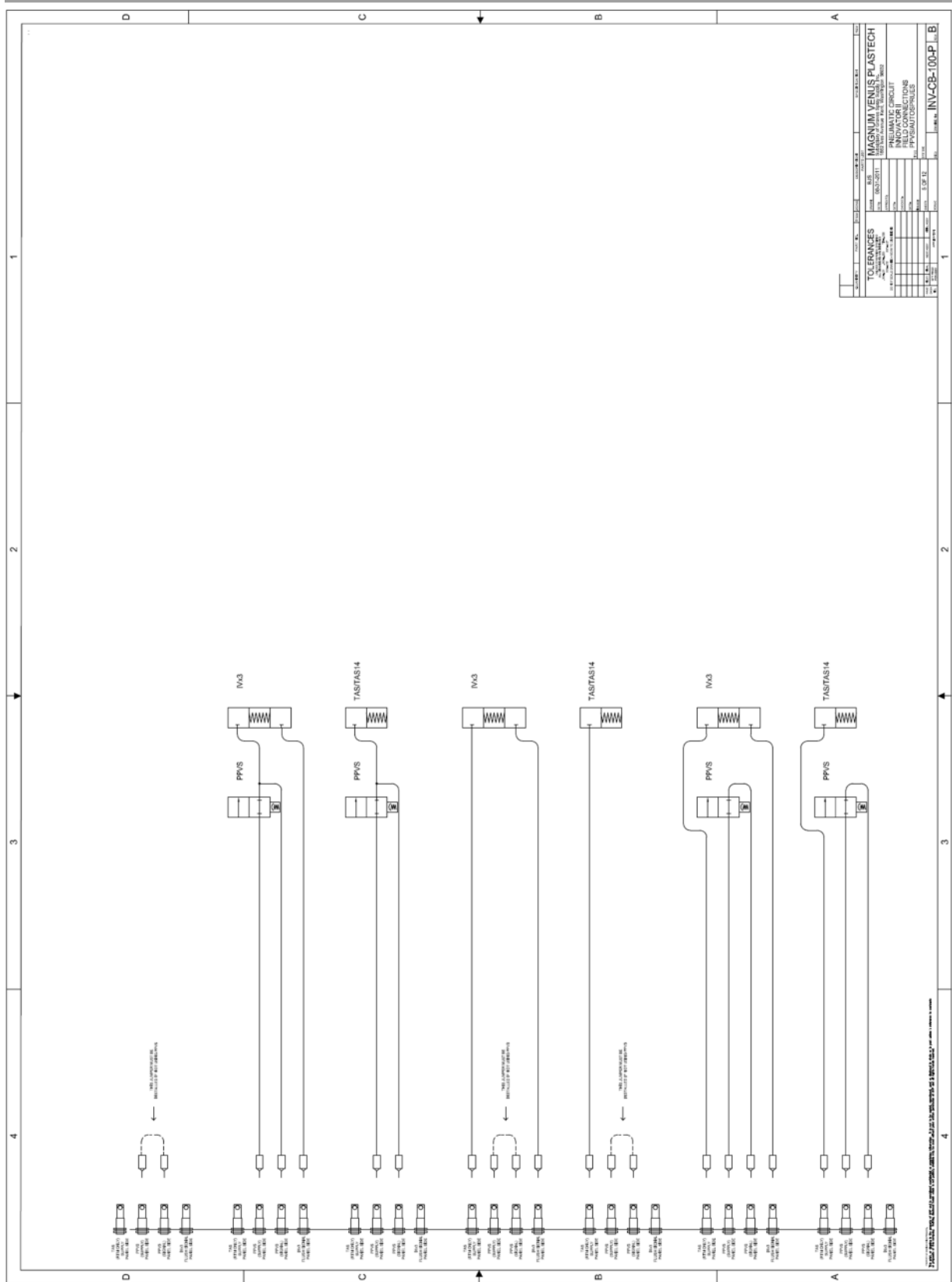

System Components

Systems can be configured differently from the base lists below. Refer to the serial plates on system components to verify part numbers when ordering repair kits or replacement parts.

All service and repair manuals are available on our website at <https://www.mvpind.com/application-support/technical-documents/>.

INV2-PAT-7-PRO

Core System Parts	
Part Number	Description
PAT-LS-12270-RTM	Innovator Pro Fluid Section
PAT-SC-3100	Patriot Slave Drive Assembly
PAT-CP-0550	Catalyst Pump Assembly
PAT-LS-12270-R-SK	Fluid Section – Seal Kit
PAT-CP-0550-SK	Seal Kit – Catalyst Pump Assembly
PAT-CJ-INV	Innovator Catalyst Jug
PAT-PH-3250-INV	3.25” Patriot Powerhead Assembly
PAT-PH-3250-SK	Seal Kit – 3.25” Patriot Powerhead
82004-01	Sp4 Pump Assembly
82009-01	MPG Valve Assembly
PRTM-DG-3000-A	Dispense Gun Assembly
PRTM-RG-1000-A	Recirculation Gun Assembly
INV-SP4-2000	SP4 Flush Tank Assembly
22021-06	Assy – 0034 Catalyst Overpressure Valve

Parts Drawings

The illustrations on the following pages are included based on the components ordered with your system and will assist with assembly and repair.

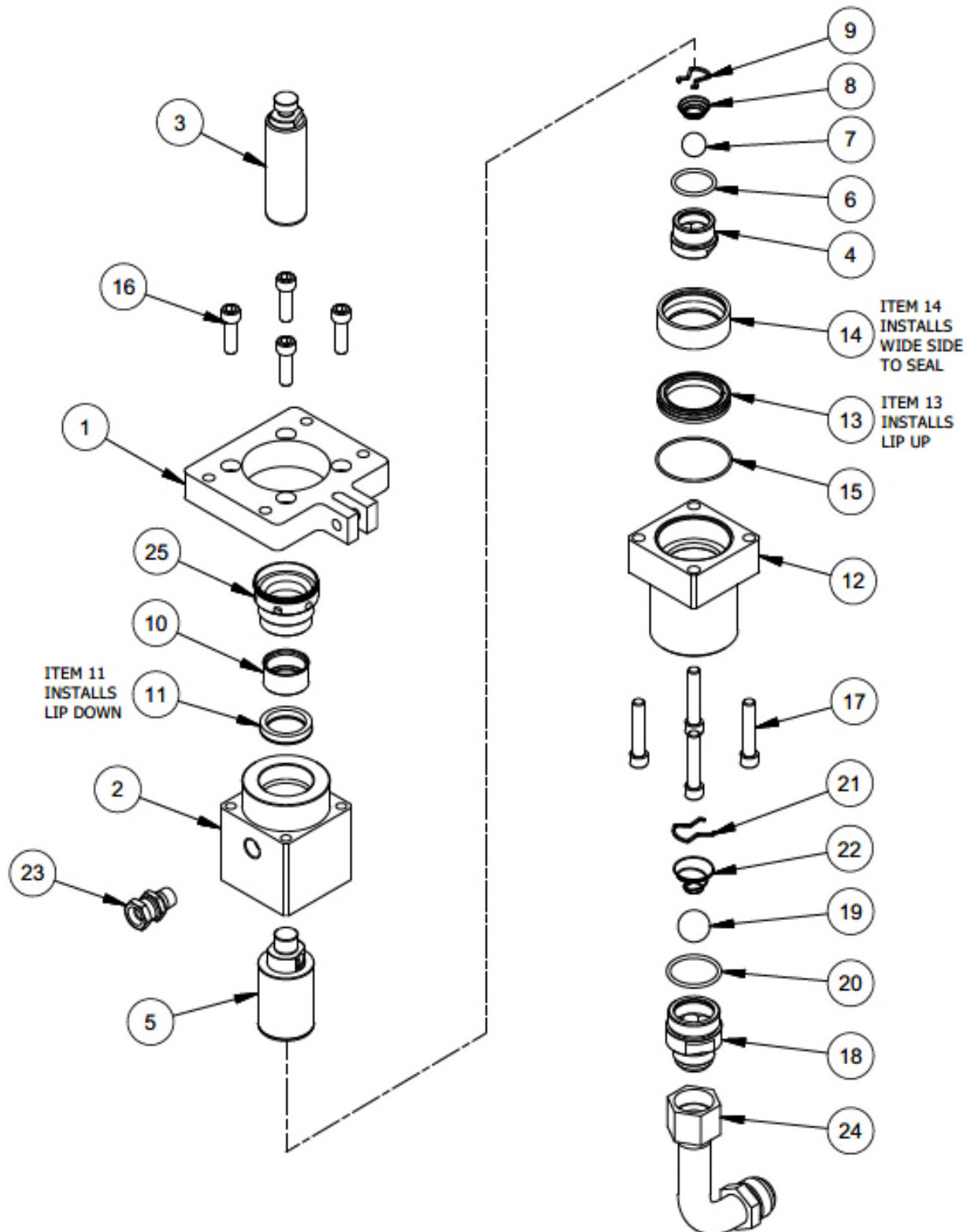

MAGNUM VENUS PLASTECH

PATRIOT RTM FLUID SECTION

PAT-LS-12270-RTM

REV:A 07/20/2017

Parts List			
ITEM	PART NUMBER	QTY	DESCRIPTION
	PAT-LS-1003	1	TRANSITION PLATE
	PAT-LS-1001	1	OUTLET BODY
	PAT-LS-1008	1	FLUID ROD 1-1/4
	PAT-LS-1009	1	PISTON VALVE
	PAT-LS-1007	1	PISTON
*	O-E-3-916	1	O-RING
	VLS-2427	1	3/4" CHROME BALL
	PAT-LS-1010	1	SPRING
	PAT-LS-1011	1	SPRING RETAINER
	PAT-LS-1005	1	ROD BUSHING
*	PAT-LS-1016	1	ROD SEAL ASSY
	PAT-LS-1002	1	INLET BODY
*	PAT-LS-1014	1	PISTON SEAL ASSY
	PAT-LS-1013	1	PISTON BUSHING
*	O-E-035	1	O-RING
	F-CS-06C-20	4	HEX SOCKET CAP SCREW - Inch
	F-CS-06C-32	4	HEX SOCKET CAP SCREW - Inch
	PAT-LS-1015	1	INLET VALVE
	PAT-LS-1017	1	1" CHROME BALL
*	O-E-3-920	1	O-RING
	VLS-2420	1	BALL STOP
	3102-16-1	1	FOOT VALVE SPRING
	PF-SW-06	1	PIPE SWIVEL
	PF-SE-SW-16J-LL	1	LONG SWIVEL ELBOW
	PAT-LS-1006	1	PACKING NUT - RTM

REPAIR KITS

PART No.	DESCRIPTION
* PAT-LS-12270-R-SK	SEAL KIT

* NOTE: ASTERISKS DENOTE PARTS USED IN SEAL KIT.

MAGNUM VENUS PLASTECH

PATRIOT RTM FLUID SECTION

PAT-LS-12270-RTM

REV:A 07/20/2017

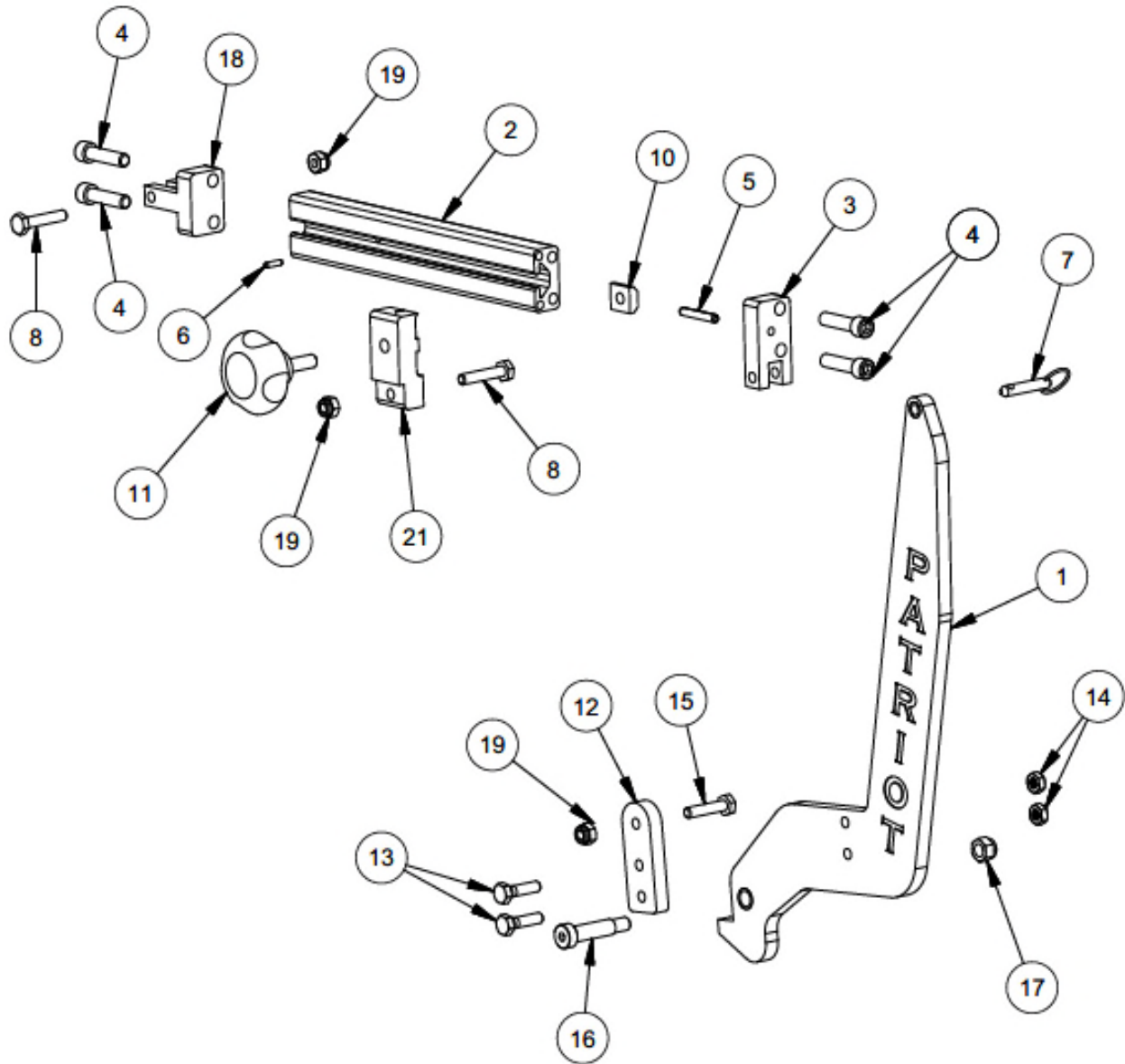

MAGNUM VENUS PLASTECH

SLAVE DRIVE ASSEMBLY	PAT-SD-3100
----------------------	-------------

REV:A 06/01/2015

Parts List			
ITEM	PART NUMBER	QTY	DESCRIPTION
1	PAT-SD-3101	1	L-ARM ASSY
2	PAT-SD-3102	1	SLAVE ARM
3	PAT-SD-3103	1	CLEVIS BLOCK
4	F-CS-05C-20	4	SOCKET HEAD CAP SCREW
5	F-RP-03-20	1	ROLL PIN
6	F-RP-02-08	1	ROLL PIN
7	F-QP-04-16-SS	1	QUICK PIN
8	02966	2	AIRCRAFT BOLT
10	PAT-SD-3108	1	T-NUT
11	PAT-SD-3105	1	KNOB
12	PAT-SD-3107	1	ALIGNMENT PLATE
13	F-HB-04C-16	2	HEX BOLT
14	F-TLN-04C	2	THIN LOCK NUT
15	F-AB-04F-19	1	AIRCRAFT BOLT
16	F-SB-06-20	1	SHOULDER BOLT
17	F-LN-05C	1	LOCK NUT
18	PAT-SD-3109	1	CLEVIS BLOCK
19	F-LN-04F	3	LOCK NUT
21	PAT-SD-3113	1	SLIDE CLEVIS

MAGNUM VENUS PLASTECH

SLAVE DRIVE ASSEMBLY

PAT-SD-3100

REV:A 06/01/2015

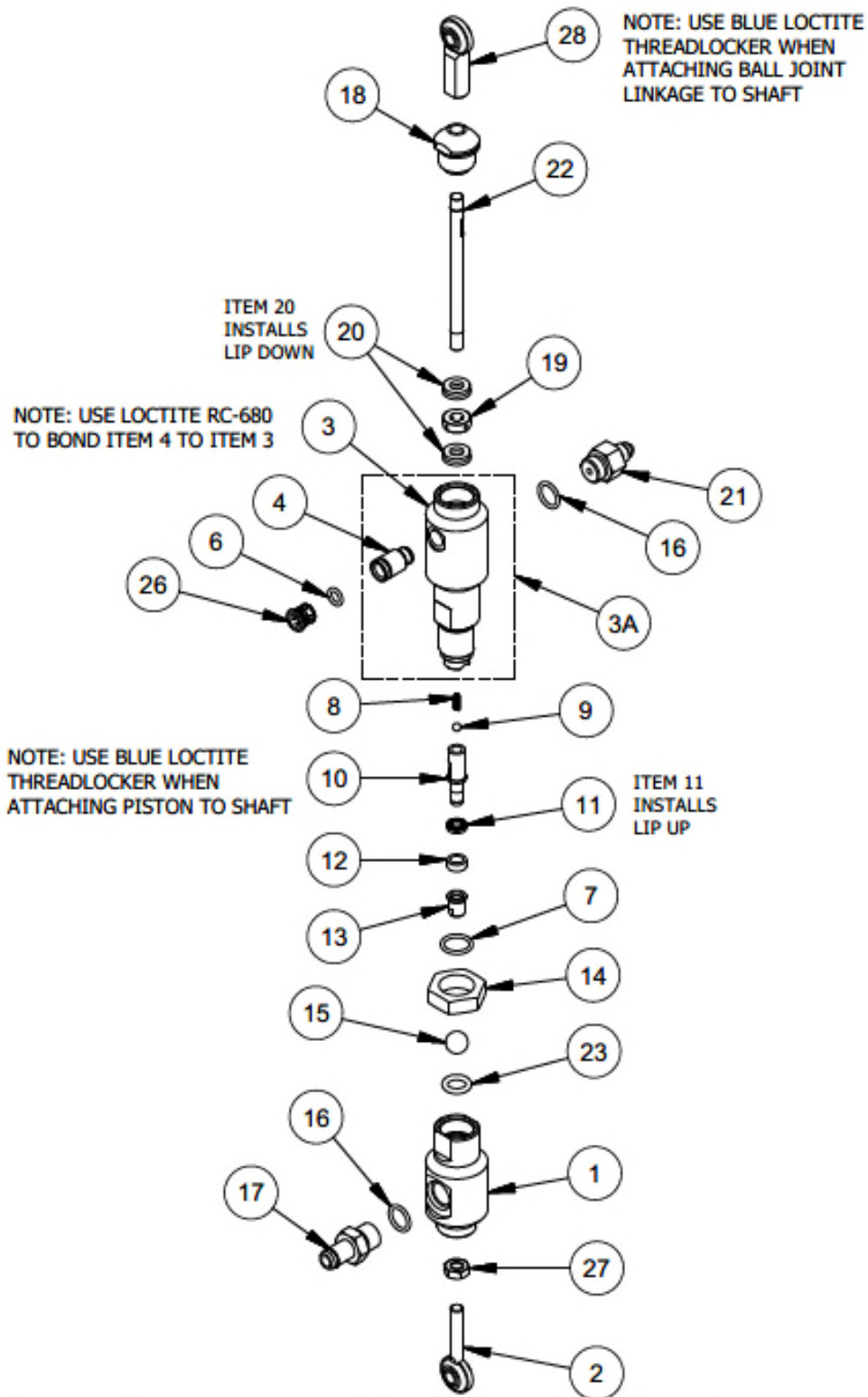

MAGNUM VENUS PRODUCTS

PATRIOT CATALYST PUMP

PAT-CP-0550

REV:B 03/22/2016



Parts List				
ITEM	PART NUMBER	QTY	DESCRIPTION	
1	PAT-CP-0502	1	INLET BODY	
2	PAT-CP-0504	1	BALL JOINT LINKAGE	
3	PAT-CP-0503	1	OUTLET BODY	
4	PAT-CP-0505	1	FITTING BODY	
*	6	O-S-010	1	O-RING
*	7	O-S-014	1	O-RING
8	4101-3-1	1	SPRING	
9	9201-1-5	1	SS BALL \varnothing 5/32	
10	4102-7-1	1	PISTON BODY	
*	11	7304-1-1	1	PISTON SEAL
*	12	4102-8-1	1	PISTON GUIDE
13	4102-9-1	1	SEAL RETAINER	
14	4101-1-1	1	LOCK NUT	
15	9201-1-14	1	SS BALL \varnothing 7/16	
*	16	O-S-013	2	O-RING
17	4101-8-1	1	INLET FITTING	
18	PAT-CP-0506	1	RETAINING NUT	
*	19	PAT-CP-0507	1	LEAK SPACER
*	20	PAT-CP-0501	2	CUP SEAL ASSEMBLY
21	51501-1	1	OUTLET FITTING	
22	PAT-CP-0508	1	CAT ROD - PAT \varnothing .265	
23	O-F-110	1	O-RING	
26	4105-5-1	1	LOCK COLLAR	
27	F-HN-04F	1	HEX NUT	
28	MS-1022	1	BALL JOINT - FEMALE	

REPAIR KIT

* PAT-CP-0550-SK (ASTERISKS DENOTE PARTS IN KIT)

ASSOCIATED PARTS AND ASSEMBLIES

3A PAT-CP-0503-A OUTLET BODY ASSEMBLY

MAGNUM VENUS PRODUCTS

PATRIOT CATALYST PUMP

PAT-CP-0550

REV:B 03/22/2016

PAT-LS-12270-R-SK
SEAL REPAIR KIT
PATRIOT RTM FLUID SECTION

PAT-LS-12270-R-SK
SEAL REPAIR KIT
PATRIOT RTM FLUID SECTION

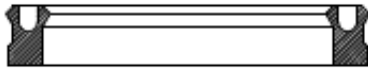

1 PC
PAT-LS-1014 SEAL ASSY

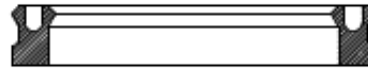

1 PC
PAT-LS-1014 SEAL ASSY

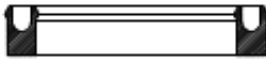

1 PCS
PAT-LS-1016 SEAL ASSY

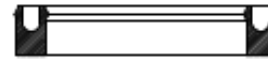

1 PCS
PAT-LS-1016 SEAL ASSY

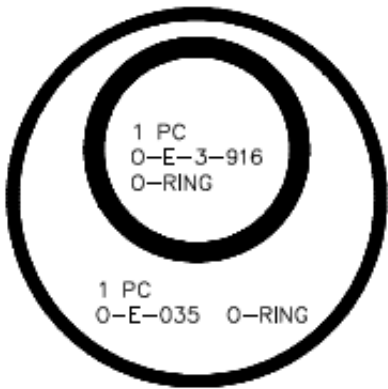

1 PC
O-E-3-916
O-RING

1 PC
O-E-035 O-RING

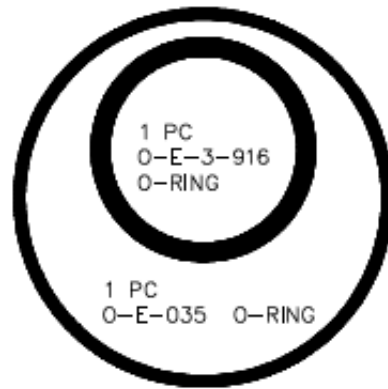

1 PC
O-E-3-916
O-RING

1 PC
O-E-035 O-RING

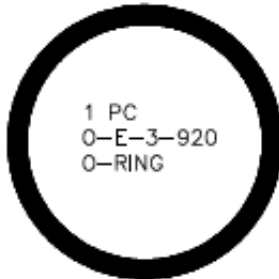



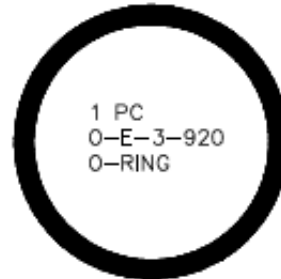



1 PC
O-E-3-920
O-RING









1 PC
O-E-3-920
O-RING







PAT-CP-0550-SK
SEAL KIT

-  1 PC
0-S-014 O-RING
-  2 PC
0-S-013 O-RING
-  1 PCS
0-S-010 O-RING
-  1 PC
7304-1-1 (PISTON SEAL)
-  1 PC
PAT-CP-0507 LEAK SPACER
-  2 PCS
PAT-CP-0501 CUP SEAL
-  1 PCS
4102-8-1 PISTON GUIDE







PAT-CP-0550-SK
SEAL KIT

-  1 PC
0-S-014 O-RING
-  2 PC
0-S-013 O-RING
-  1 PCS
0-S-010 O-RING
-  1 PC
7304-1-1 (PISTON SEAL)
-  1 PC
PAT-CP-0507 LEAK SPACER
-  2 PCS
PAT-CP-0501 CUP SEAL
-  1 PCS
4102-8-1 PISTON GUIDE

PAT-CP-0550-SK
SEAL KIT

-  1 PC
0-S-014 O-RING
-  2 PC
0-S-013 O-RING
-  1 PCS
0-S-010 O-RING
-  1 PC
7304-1-1 (PISTON SEAL)
-  1 PC
PAT-CP-0507 LEAK SPACER
-  2 PCS
PAT-CP-0501 CUP SEAL
-  1 PCS
4102-8-1 PISTON GUIDE

PAT-CP-0550-SK
SEAL KIT

-  1 PC
0-S-014 O-RING
-  2 PC
0-S-013 O-RING
-  1 PCS
0-S-010 O-RING
-  1 PC
7304-1-1 (PISTON SEAL)
-  1 PC
PAT-CP-0507 LEAK SPACER
-  2 PCS
PAT-CP-0501 CUP SEAL
-  1 PCS
4102-8-1 PISTON GUIDE

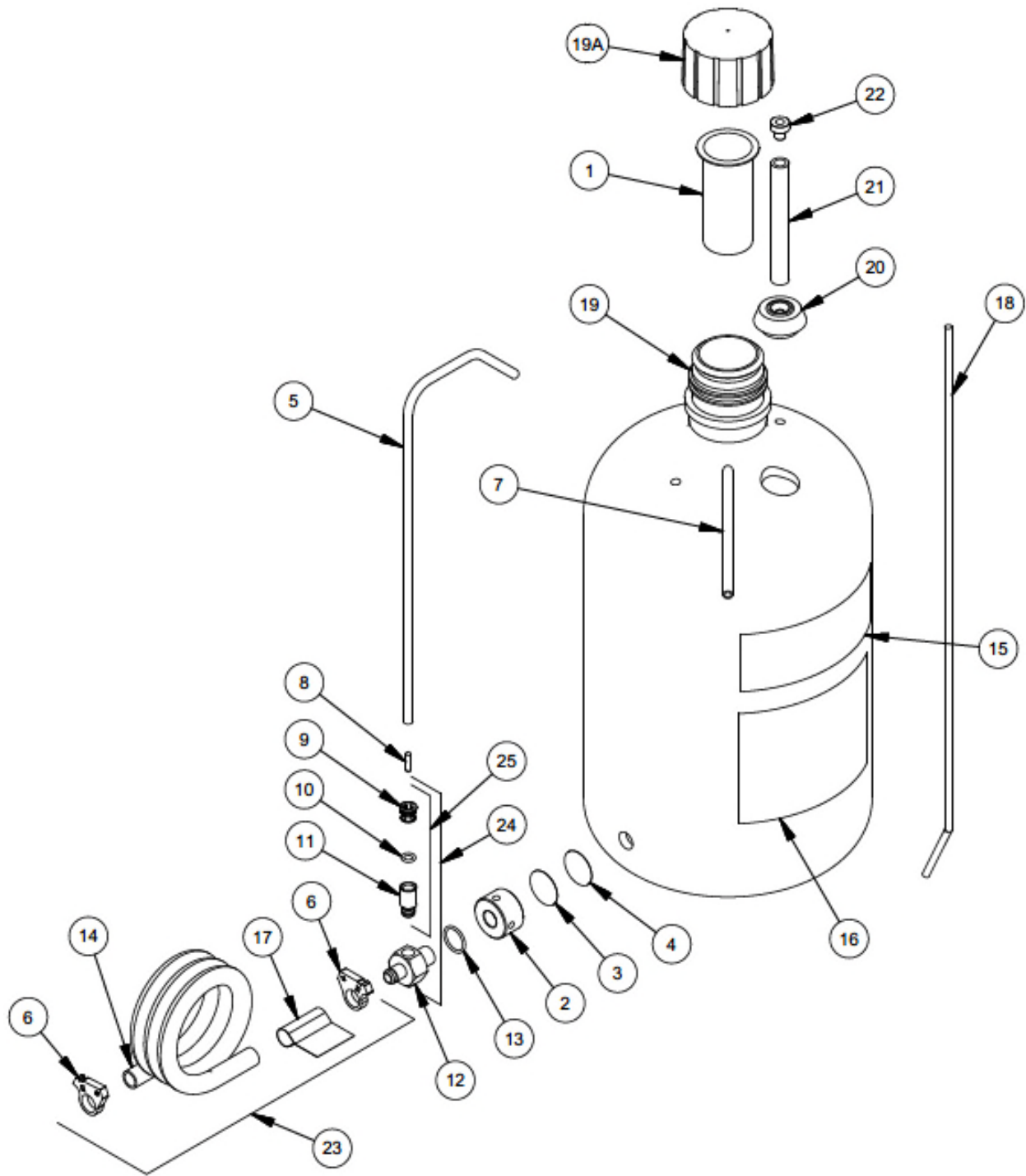

MAGNUM VENUS PLASTECH

PATRIOT 2 GALLON CATALYST JUG - INNOVATOR

PAT-CJ-INV

REV: B 01/27/2014

SHEET 1 / 2

10/14/2010

Parts List			
ITEM	PART NUMBER	QTY	DESCRIPTION
1	8801-1-100	1	100 MESH CAT JUG SCREEN
2	4105-10-1	1	FILTER SCREEN NUT
3	4105-7-1	1	60 MESH SCREEN
4	4105-6-1	1	100 MESH SCREEN
5	4105-4-1	1	SIGHT TUBE - 1/4x 14"
6	7701-2-2	2	SUCTION HOSE CLAMP
7	MS-2052-1	3 FT	1/4" CLEAR POLY TUBE
8	4105-9-1	1	SIGHT TUBE FLOAT
9	4105-5-1	1	LOCK COLLAR
10	O-S-010	1	O-RING
11	4105-1-1	1	TUBE FITTING BODY
12	4105-12-1	1	CAT JUG FITTING
13	O-S-016	1	O-RING
14	01419	4 FT	1/2" POLY TUBE
15	6701-4-EN	1	CAUTION DECAL
16	6701-15-EN	1	MAINTENANCE DECAL
17	6701-16-EN	1	SUCTION HOSE DECAL
18	4105-8-1	1	PIN WRENCH
19	PAT-CJ-4	1	2 GAL JUG WITH CAP
20	6634	1	SEAL
21	6049	1	SIGHT GLASS
22	6655	1	PLUG

ASSOCIATED PARTS AND ASSEMBLIES

ITEM	PART No.	QTY.	DESCRIPTION
19A	8802-1-1	1	CAP ONLY
23	4105-2-01	1	1/2" x 4' FEED LINE
24	4105-12-01	1	OUTLET FITTING
25	4105-1-01	1	TUBE FITTING

MAGNUM VENUS PLASTECH

PATRIOT 2 GALLON CATALYST JUG - INNOVATOR

PAT-CJ-INV

REV:B 01/27/2014

SHEET 2 / 2

10/14/2010

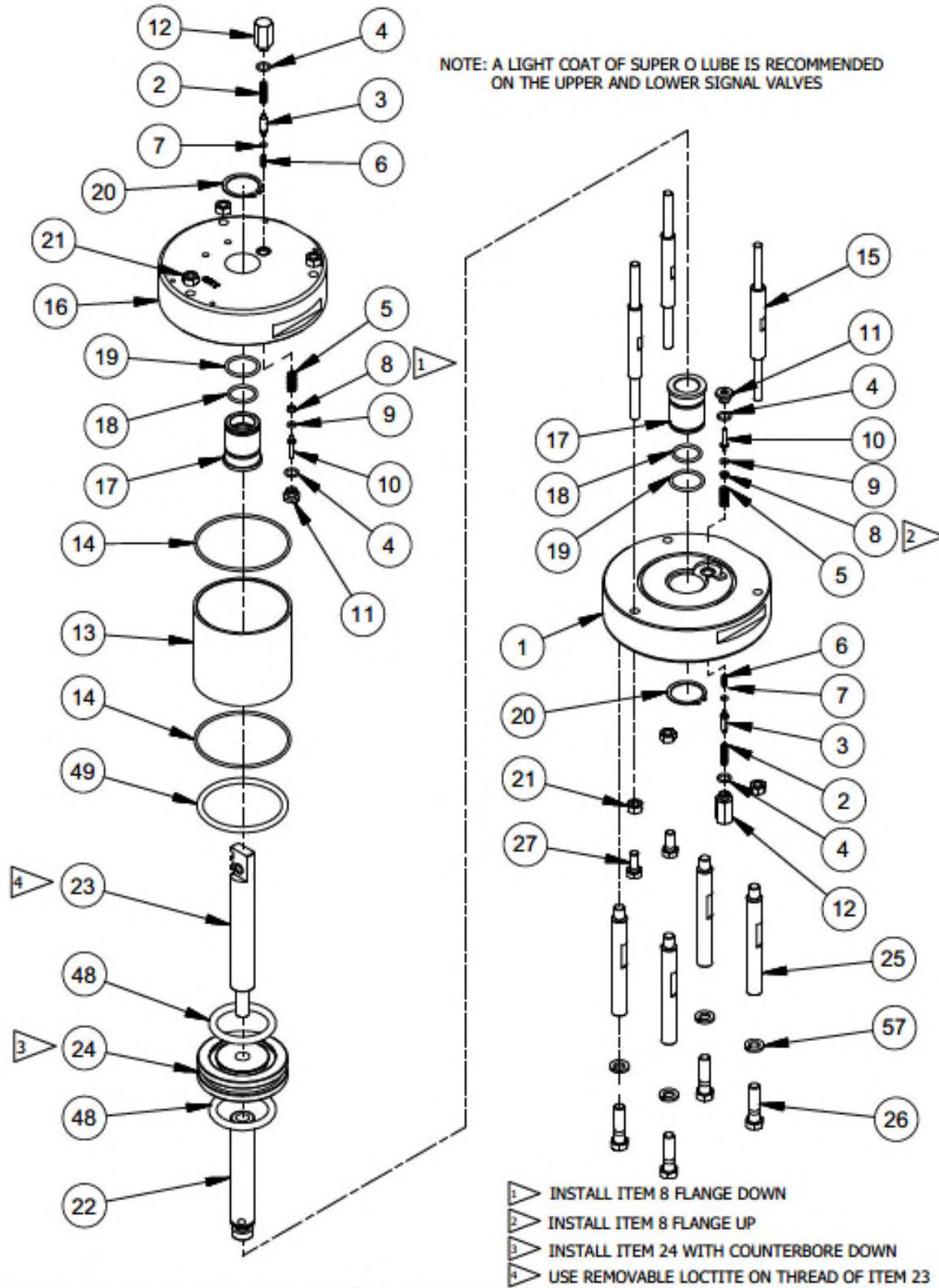

MAGNUM VENUS PLASTECH

3-1/4 PATRIOT POWER HEAD

PAT-PH-3250-INV

REV: A 05/24/11



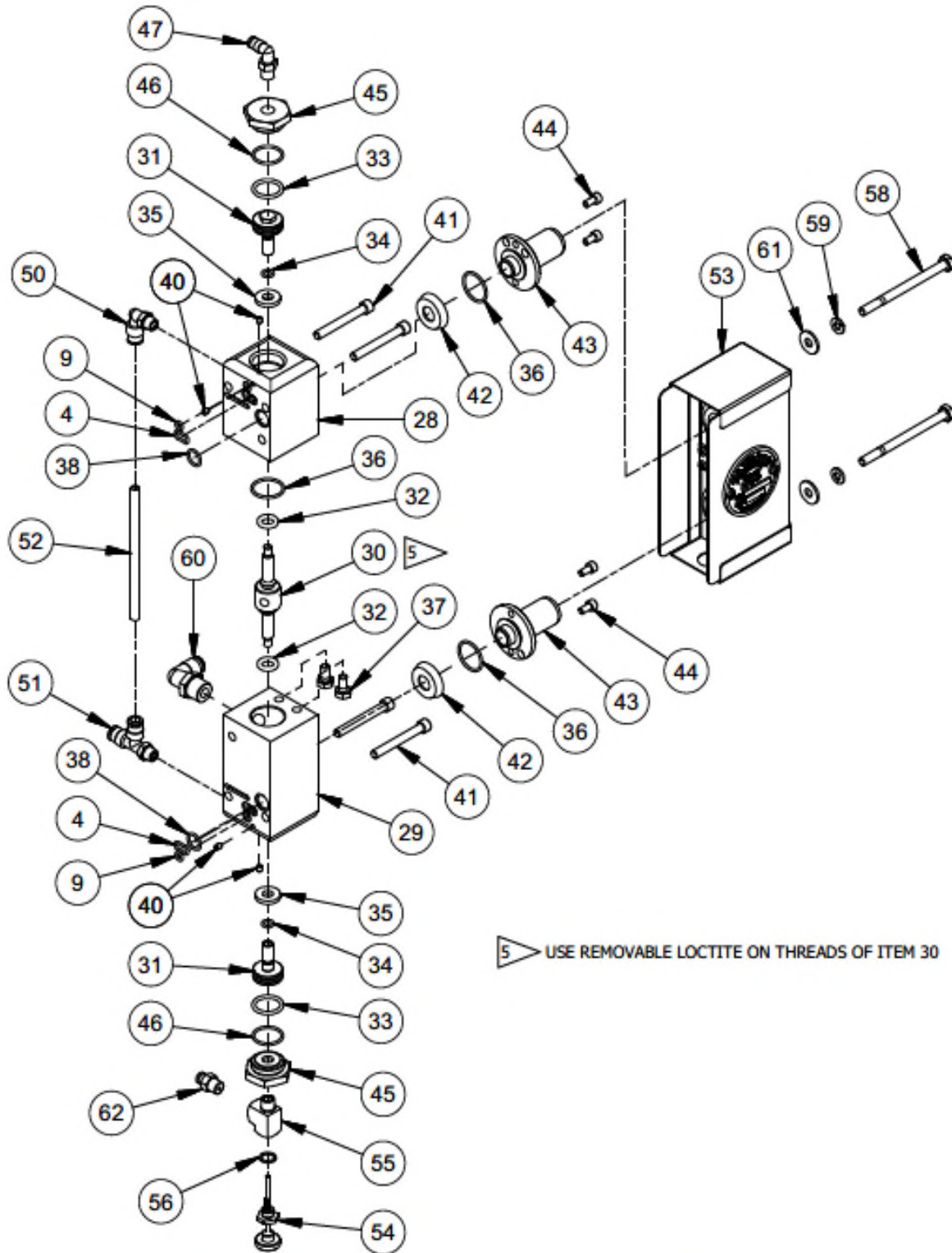

MAGNUM VENUS PLASTECH

3-1/4" PATRIOT POWER HEAD

PAT-PH-3250-INV

REV: A 05/24/11



PAT- PH-3250 PARTS LIST			
ITEM	PART NUMBER	QTY	DESCRIPTION
	1	1	PAT-PH-3204 LOWER END CAP
	2	2	MPH-2533 COMPRESSION SPRING
	3	2	MPH-2540 INLET ROD- PILOT VALVE
*	4	6	O-B-012 O-RING
	5	2	MPH-2528 SPRING
	6	2	MPH-2526 SPRING
*	7	2	O-U-006 O-RING
	8	2	MPH-2512 SEAL GUIDE- PILOT VALVE
*	9	4	O-B-008 O-RING
	10	2	MPH-2513 VALVE STEM- PILOT VALVE
	11	2	MPH-2511-01 STEM SEAL ASSY- PILOT VALVE
	12	2	MPH-2541 SPRING HOUSING- PILOT VALVE
	13	1	PAT-PH-3203 CYLINDER - \varnothing 3-1/4x 2" STROKE
*	14	2	O-B-152 O-RING
	15	3	PAT-PH-3206 TIE ROD
	16	1	PAT-PH-3212 UPPER END CAP
	17	2	MPH-4254 BUSHING- 7/8 DIA. PISTON ROD
*	18	2	O-B-118 O-RING
*	19	2	O-B-121 O-RING
	20	2	MPH-3261 SNAP RING - EXTERNAL
	21	6	F-HN-05F HEX NUT
	22	1	PAT-PH-5009 LOWER ROD
	23	1	PAT-PH-5008 UPPER ROD ASSY
	24	1	MPH-3251 PISTON - 3-1/4" POWER HEAD
	25	4	PAT-PH-5011 TIE ROD
	26	4	F-HB-06C-24-GR8 HEX BOLT
	27	2	F-HB-05C-12 HEX BOLT
	28	1	PAT-PH-3201 UPPER VALVE BLOCK
	29	1	PAT-PH-3202 LOWER VALVE BLOCK
	30	1	PAT-PH-3205 VALVE ROD POPPET
	31	2	MPH-2517 VALVE PISTON
*	32	2	O-U-204-90 O-RING
*	33	2	O-B-116 O-RING
*	34	2	O-D-010-90 O-RING
	35	2	MPH-3262 PISTON STOP
*	36	3	O-B-020 O-RING
	37	2	F-HB-04C-08 HEX BOLT
*	38	2	O-B-013 O-RING
	40	4	F-SS-832-02-SS SET SCREW
	41	4	F-CS-04C-32-SS SOCKET HEAD CAP SCREW
*	42	2	MPH-2529 DIAPHRAGM
	43	2	MPH-2522 VALVE EXHAUST PORT
	44	4	F-CS-1024-06-SS CAP SCREW
	45	2	MPH-2521 VALVE END CAP
*	46	2	O-B-019 O-RING
	47	1	PTF90-02-4MM MALE ELBOW
*	48	2	O-B-404 O-RING
*	49	1	O-B-336 O-RING
	50	1	MPH-2539 MALE ELBOW
	51	1	MPH-2538 MALE POLY TEE FITTING
	52	.40ft	MS-2052-1 POLY TUBE
	53	1	PAT-PH-3210-01 MUFFLER ASSY. -2" STROKE
	54	1	MPH-2546-01 VALVE STEM ASSY
	55	1	PF-ST-02-BR TEE FITTING
	56	1	MPH-2545 SEAL
	57	4	F-SW-06 LOCK WASHER
	58	2	F-HB-04C-56-SS HEX BOLT
	59	2	F-SW-04-SS LOCK WASHER
	60	1	PTF90-06-05 MALE ELBOW
	61	2	F-FW-04 FLAT WASHER
	62	1	PTF-02-4MM MALE CONNECTOR

* ASTERISKS DENOTE PARTS INCLUDED IN PAT-PH-3250-SK SEAL KIT

OPTIONAL PARTS AND ASSEMBLIES

PART No.	QTY.	DESCRIPTION
MPH-2542	1	RESET PUTTON ASSY
PAT-PH-SB	1	SHIFT BLOCK ASSY

MAGNUM VENUS PLASTECH

3-1/4" PATRIOT POWER HEAD

PAT-PH-3250-INV

REV: A 05/24/11



PAT-PH-3250-SK
SEAL KIT 3-1/4" AIR MOTOR

 2 PCS
O-U-006 O-RING

 4 PCS
O-B-008 O-RING

 6 PCS
O-B-012 O-RING

 2 PCS
O-B-013 O-RING

 2 PCS
O-B-116 O-RING

 2 PCS
O-B-019 O-RING

 2 PCS
O-B-118 O-RING

 2 PCS
O-U-204-90 O-RING

 2 PCS
O-D-010-90 O-RING

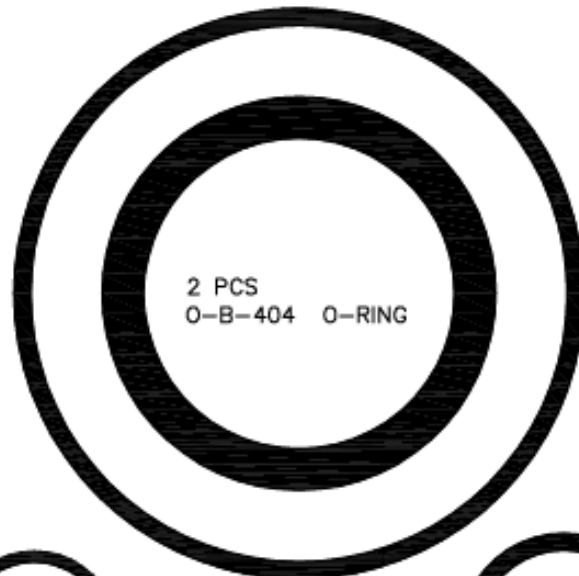

 3 PCS
O-B-020
O-RING

2 PCS
O-B-152 O-RING

 2 PCS
O-B-121
O-RING

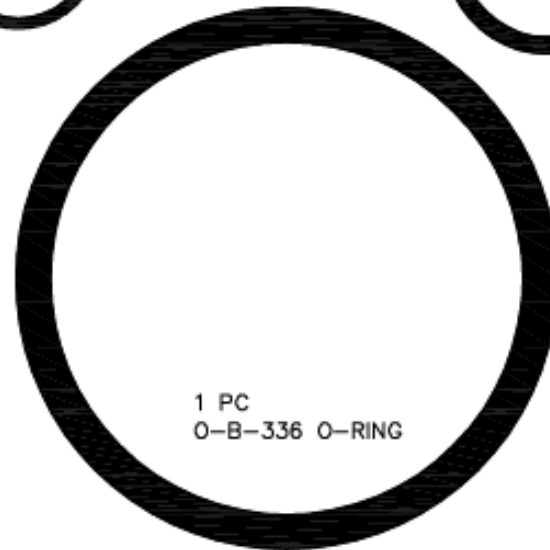

 2 PCS
MPH-2529 1/4" DIAPHRAGM

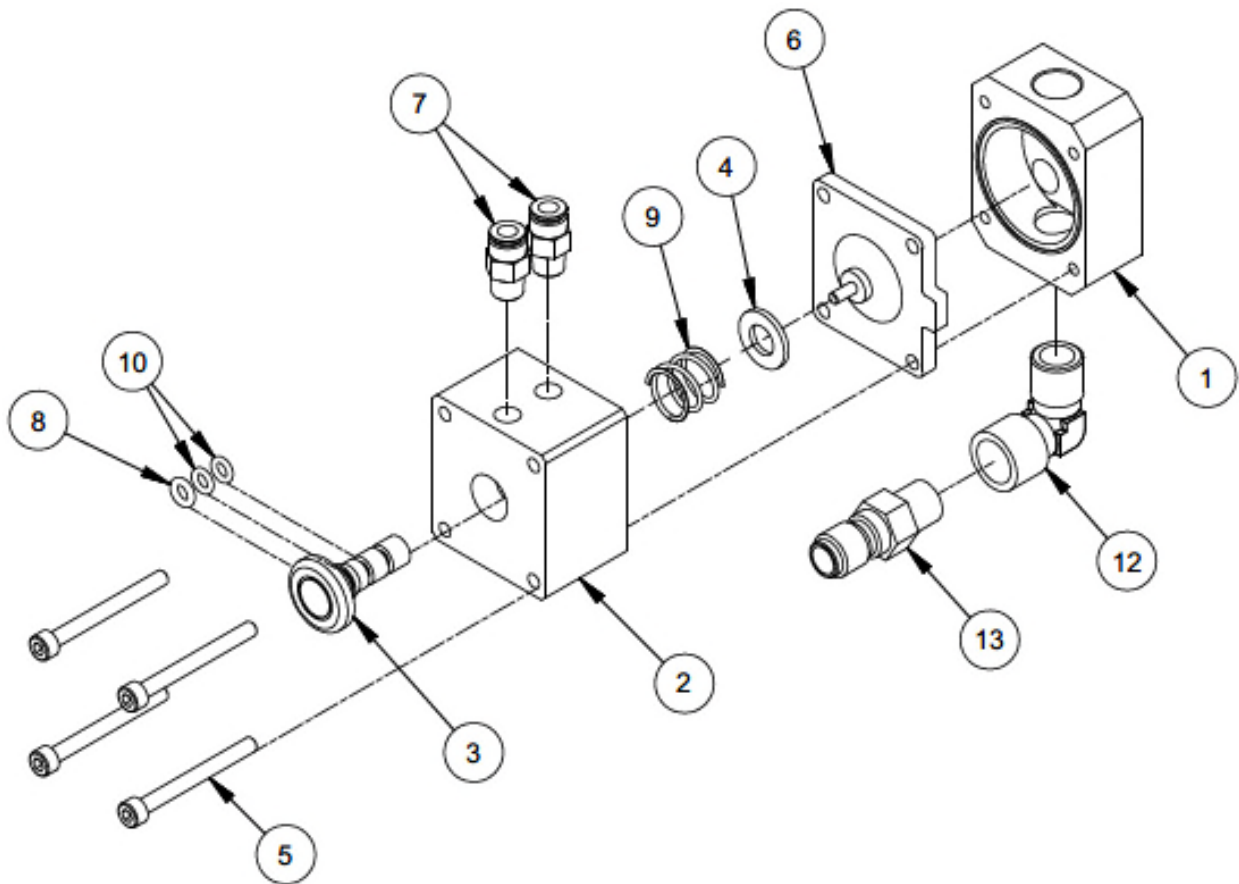

MAGNUM VENUS PRODUCTS

MEGAJECT MPG BLOCK

MJH-1450 PRO INNOVATOR MPG BLOCK

REV: -

SHEET 1 / 2

7/17/2020

Parts List			
ITEM	PART NUMBER	QTY	DESCRIPTION
1	0731	1	MPG SEAT BLOCK
2	0732	1	MPG TOP BLOCK
3	0733	1	MPG SPOOL
4	0353	1	WASHER M10
5	0314	4	SOCKET CAP HEAD M5 X 50MM
6	0193	1	PTFE LINED DIAPRAGM, 52MM
7	07223	2	MALE CONNECTOR
8	0750	1	O-RING
9	0598	1	SPRING MPG MKII
10	0740	2	O-RING
12	0187	1	3/8 BSP MALE/FEMALE ELBOW
13	0463	1	AUTOSPRUE RESIN CONNECTOR

MAGNUM VENUS PRODUCTS

MEGAJECT MPG BLOCK

MJH-1450 PRO INNOVATOR MPG BLOCK

REV: -

SHEET 2 / 2

7/17/2020

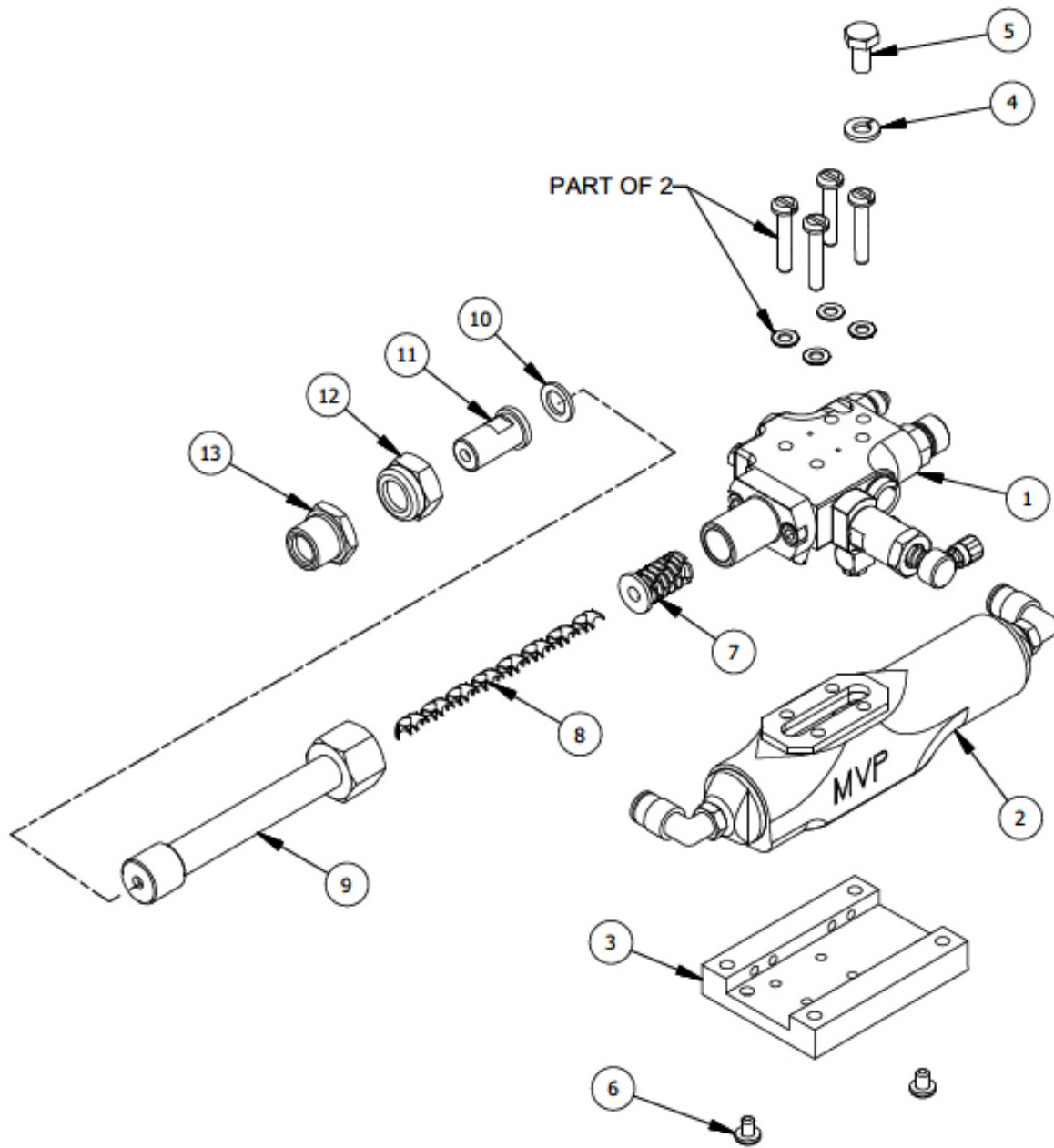

MAGNUM VENUS PLASTECH

PRO RTM DISPENSE GUN

PRTM-DG-3000-A

REV: B 10/17/12

SHEET 1 / 2

8/12/2009

Parts List			
ITEM	PART NUMBER	QTY	DESCRIPTION
1	5104-00-01-A-INT	1	PRO GUN HEAD ASSEMBLY
2	PRTM-RG-1200-A	1	ACTUATOR ASSEMBLY
3	58704-1	1	MOUNTING PAD
4	F-SW-04	1	LOCK WASHER
5	F-HB-04C-08	1	HEX BOLT
6	02806-2	2	10-24 PAN HEAD SCREW
7	5107-27-3	1	TURBULENT MIXER
8	MIX-1080	1	STATIC MIXER ELEMENT
9	50091-1	1	MIXER HOUSING
10	02149-1	1	NOZZLE SEAL
11	72711-1	1	NOZZLE ADAPTER
12	8704-4-1	1	NOZZLE CAP
13	PF-RB-06-04	1	BUSHING

REPAIR KIT

PART No.	DESCRIPTION
PRTM-DG-3000-A-RK	REPAIR KIT

MAGNUM VENUS PLASTECH

PRO RTM DISPENSE GUN

PRTM-DG-3000-A

REV:B 10/17/12

SHEET 2 / 2

8/12/2009

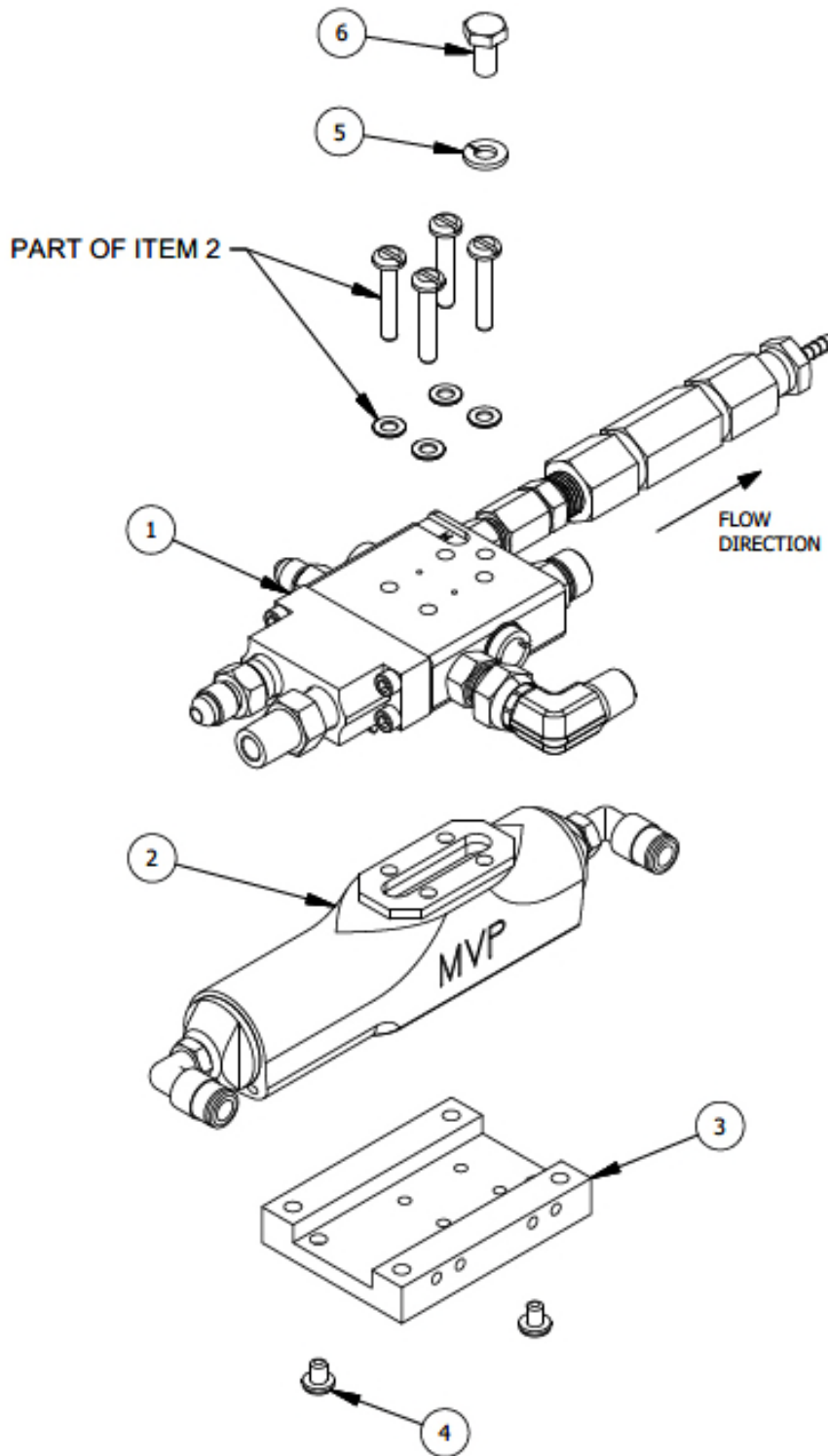

MAGNUM VENUS PRODUCTS

RECIRCULATION GUN

PRTM-RG-1000-A

REV:D 03/23/2016

SHEET 1 / 2

8/11/2009



Parts List			
ITEM	PART NUMBER	QTY	DESCRIPTION
1	PRTM-RG-1100	1	RECIRCULATION GUN BLOCK
2	PRTM-RG-1200-A	1	ACTUATOR ASSEMBLY
3	58704-1	1	MOUNTING PAD
4	02806-2	2	10-24 PAN HEAD SCREW
5	F-SW-04	1	LOCK WASHER
6	F-HB-04C-08	1	HEX BOLT

REPAIR KIT

PART No.	DESCRIPTION
CPD-4000-A-INV-RK	REPAIR KIT

MAGNUM VENUS PRODUCTS

RECIRCULATION GUN

PRTM-RG-1000-A

REV:D 03/23/2016

SHEET 2 / 2

8/11/2009

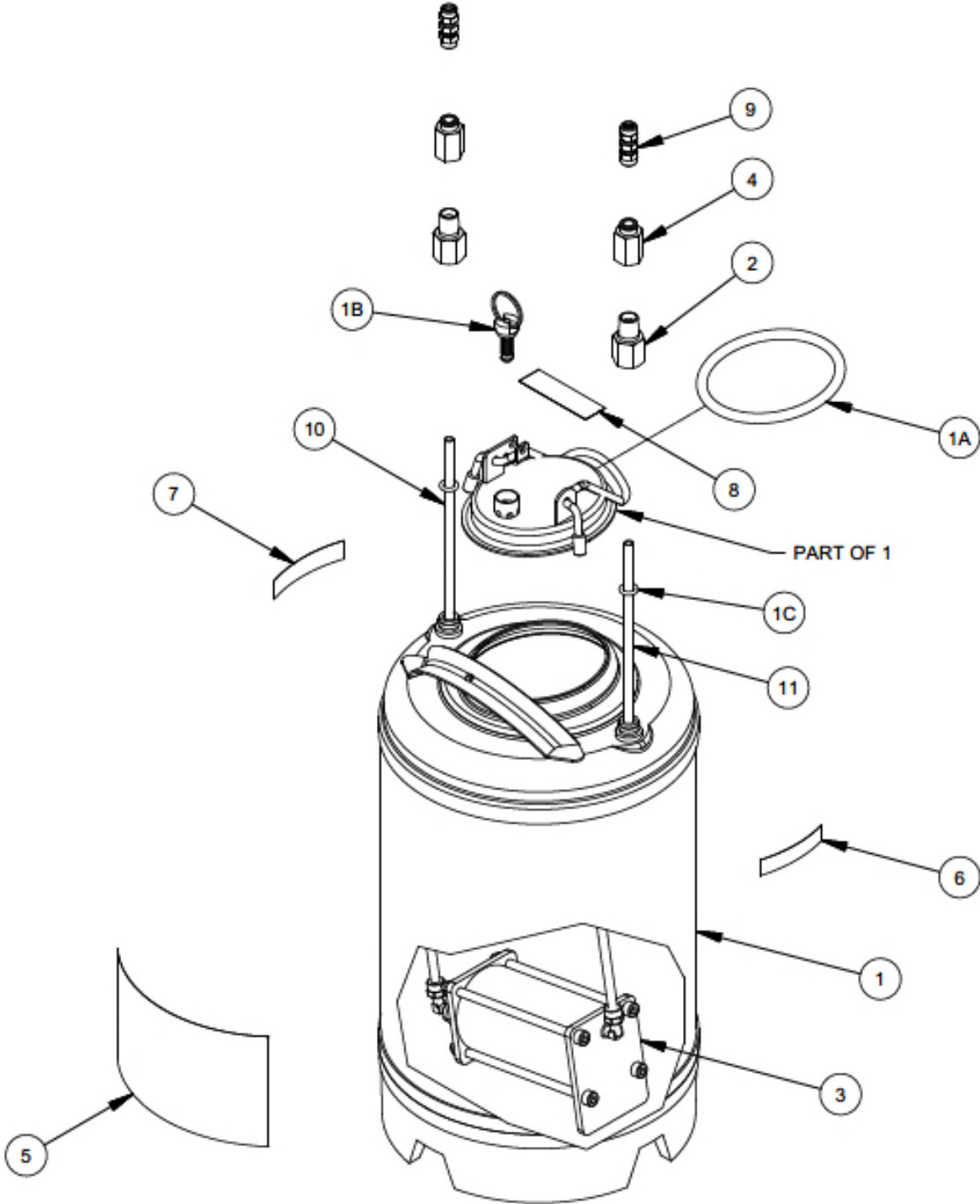

MAGNUM VENUS PLASTECH

INNOVATOR FLUSH TANK ASSEMBLY	INV-SP4-2000
-------------------------------	--------------

REV:

SHEET 1 / 2

2/5/2015

Parts List			
ITEM	PART NUMBER	QTY	DESCRIPTION
1	INV-FT-1001	1	3 GALLON FLUSH TANK
2	55210-1	2	FLUSH TANK FITTING
3	ASSY-0376	1	SP4 FLUSH TANK PUMP
4	07229-DO	2	FEMALE CONNECTOR
5	95172-EN	1	FLUSH TANK DECAL
6	6701-13	1	FLUSH TANK DECAL AIR
7	6701-14	1	FLUSH TANK DECAL SOLVENT
8	6701-12	1	FLUSH TANK DECAL PRESSURE RELIEF INSTRUCTION
9	00390	2	POLY FITTING - UNION
10	01443	3 FT	TUBING
11	MS-2052-1	3 FT	TUBING

PARTS INCLUDED IN ITEM 1 BUT AVAILABLE SEPARATELY			
ITEM	PART NUMBER	QTY	DESCRIPTION
1A	O-E-5-381	1	O RING
1B	8703-5-2	1	TANK RELIEF VALVE - 1 PSI CRACK
1C	O-E-109	2	O-RING

MAGNUM VENUS PLASTECH

INNOVATOR FLUSH TANK ASSEMBLY

INV-SP4-2000

REV:

SHEET 2 / 2

2/5/2015

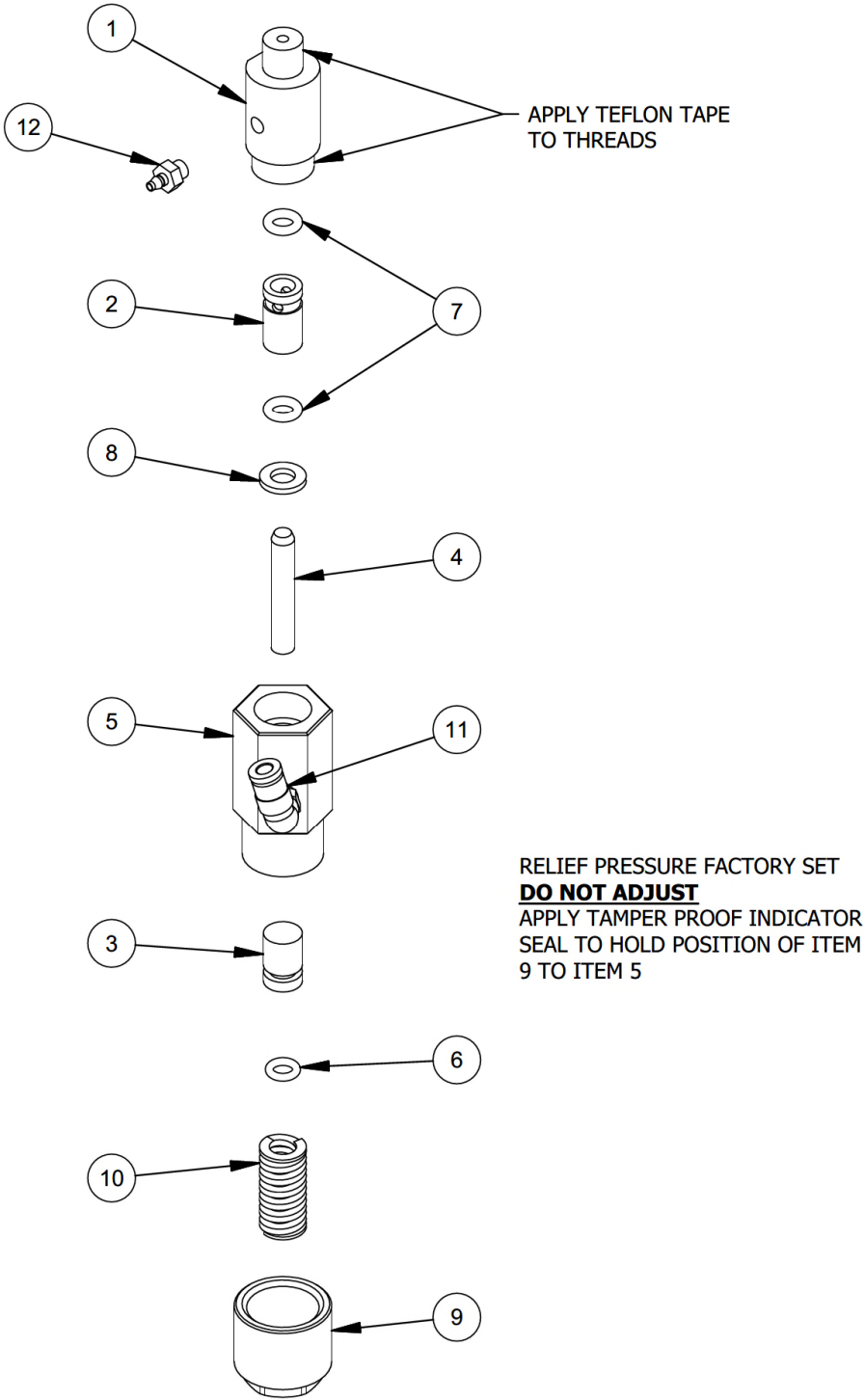

MAGNUM VENUS PRODUCTS

CATALYST OVER PRESSURE VALVE	ASSY-0034
------------------------------	-----------

REV: B 04/28/2020

SHEET 1 / 2

9/9/2015



Parts List			
ITEM	PART NUMBER	QTY	DESCRIPTION
1	1032	1	CATALYST O/P VALVE LOWER BODY
2	1034	1	CATALYST O/P VALVE SLEEVE
3	1036	1	CATALYST O/P VALVE PISTON
4	1033	1	CATALYST O/P VALVE ROD
5	1035	1	CATALYST O/P VALVE UPPER BODY
6	0744	1	O-RING
7	3316	2	O-RING
8	0338	1	WASHER M6
9	0671-A	1	VENT PLUG 1/2 BSP FEMALE
10	0945	1	SPRING O/P VALVE (BLUE)
11	0645	1	SWIVEL ELBOW
12	6759	1	BARB FITTING

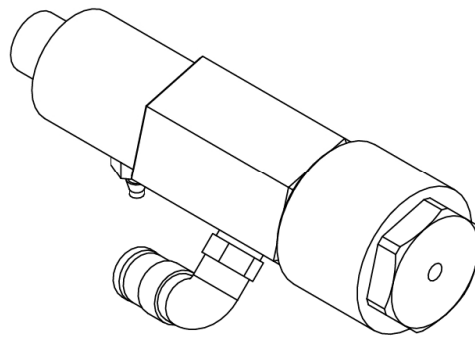

MAGNUM VENUS PRODUCTS

CATALYST OVER PRESSURE VALVE

ASSY-0034

REV: B 04/28/2020

SHEET 2 / 2

9/9/2015



Magnum Industries Europe Ltd. t/a Magnum Venus Products

Official Distributor of MVP Range in the United Kingdom and Ireland

Unit 22a, Navigation Drive, Hurst Business Park,
Brierley Hill, West Midlands, DY5 1UT, UK.

phone: +44 (0)1384 486222
email: info@mvpeurope.co.uk
website: www.mvpeurope.co.uk