

3-Component Pro Gun

Manual

This manual is applicable to the following models:

- CP3-1000
- CP3-2000

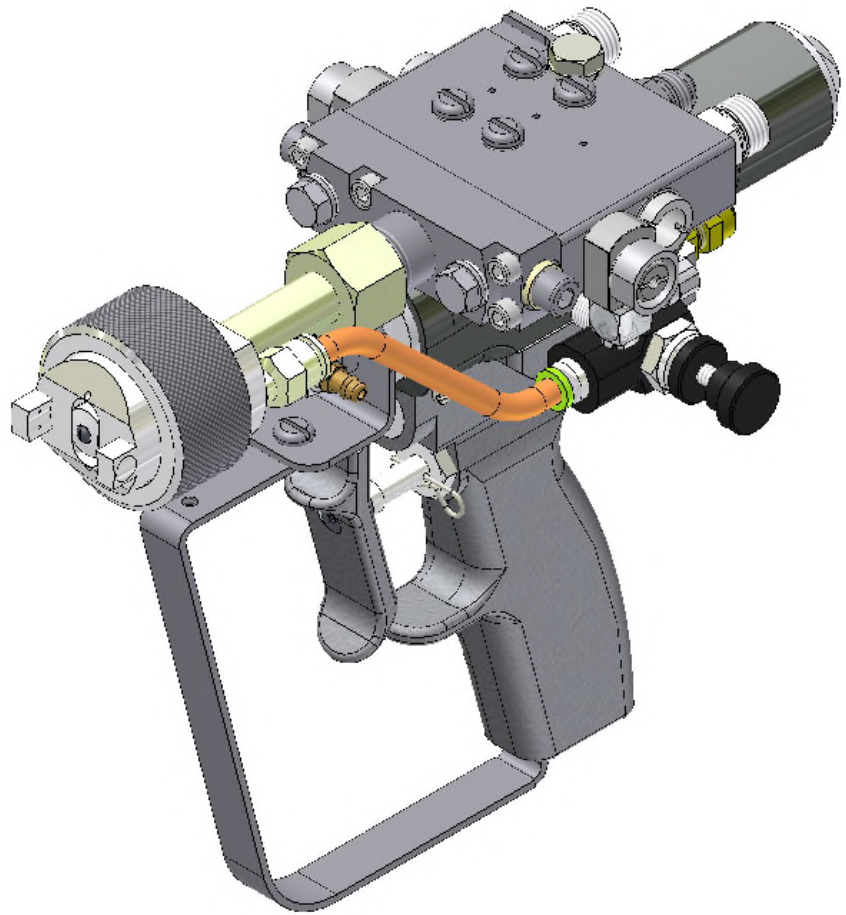

Rev. September 2019



Magnum Industries Europe Ltd. t/a Magnum Venus Products

Official Distributor of MVP Range in the United Kingdom and Ireland

Unit 22a, Navigation Drive, Hurst Business Park,
Brierley Hill, West Midlands, DY5 1UT, UK.

phone: +44 (0)1384 486222
email: info@mvpeurope.co.uk
website: www.mvpeurope.co.uk



Table of Contents

| Section | Page |
|---|-------------|
| • Table of Contents | 3 |
| • Safety & Warning Information | 4 |
| • Introduction | 15 |
| • Getting Started | 16 |
| • Disconnecting from the Unit | 16 |
| • Disassembling the Gun | 18 |
| • Reassembling Gun Block | 23 |
| • Rebuilding Actuator | 27 |
| • Rebuilding Gun Handle | 28 |
| • Reassembling Gun | 31 |
| • Parts Information | 31 |

Safety & Warning Information

Warnings

Due to the vast number of chemicals that could be used and their varying chemical reactions, the buyer and user of this equipment should determine all factors relating to the fluids used, including any of the potential hazards involved. Particular inquiry and investigation should be made into potential dangers relating to toxic fumes, fires, explosions, reaction times, and exposure of human beings to the individual components or their resultant mixtures. MVP assumes no responsibility for loss, damage, expense or claims for bodily injury or property damage, direct or consequential, arising from the use of such chemical components.

The end user is responsible for ensuring that the end product or system complies with all the relevant laws in the country where it is to be used and that all documentation is adhered to.

Recommended Occupational Safety & Health Act (OSHA) Documentation:

- 1910.94 Pertaining to ventilation
- 1910.106 Pertaining to flammable liquids
- 1910.107 Pertaining to spray finishing operations, particularly paragraph (m), Organic Peroxides and Dual Component Coatings

For Additional information, contact the Occupational Safety and Health Administration (OSHA) at <https://www.osha.gov/about.html>.

Recommended National Fire Protection Association (NFPA) Documentation:

- NFPA No.33 Chapter 14 Organic Peroxides and Dual Component Materials
- NFPA No. 63 Dust Explosion Prevention
- NFPA No. 70 National Electrical Code
- NFPA No. 77 Static Electricity
- NFPA No. 91 Blower and Exhaust System
- NFPA No. 654 Plastics Industry Dust Hazards

Fire Extinguisher – code ABC, rating number 4a60bc using Extinguishing Media –Foam, Carbon Dioxide, Dry Chemical, Water Fog, is recommended for this product and applications.

The following general warnings and guidelines are for the setup, use, grounding, maintenance, and repair of equipment. Additional product-specific warnings may be found throughout this manual as applicable. Please contact your nearest MVP Technical Service Representative if additional information is needed.

Safety Precautions

- Avoid skin contact and inhalation of all chemicals.
- Review Material Safety Data Sheet (MSDS) to promote the safe handling of chemicals in use.
- Restrict the use of all chemicals to designated areas with good ventilation.
- Chemicals are flammable and reactive.
- Noxious fumes released when combusted.
- Operate equipment in a ventilated environment only.
- Uncured liquid resins are highly flammable unless specifically labeled otherwise.
- Cured laminate, accumulations of overspray, and laminate sandings are highly combustible.
- Do not operate or move electrical equipment when flammable fumes are present.
- Ground all equipment.
- If a spark is seen or felt, immediately halt operation. Do not operate the equipment until the issue has been identified and repaired.
- Contaminated catalyst may cause fire or explosion.
- Containers may explode if exposed to fire / heat.
- Use and store chemicals away from heat, flames, and sparks.
- Do not smoke in work areas or near stored chemicals.
- Do not mix Methyl Ethyl Ketone Peroxide (MEKP) with materials other than polyethylene.
- Do not dilute MEKP.
- Keep food and drink away from work area.



Physical Hazards

- Never look directly into the spray gun fluid tip. Serious injury or death can result.
- Never aim the spray gun at or near another person. Serious injury or death can result.
- Chemical compounds can be severely irritating to the eyes and skin.
- Inhalation, ingestion, or injection may damage internal organs and lead to pulmonary disorders, cancers, lymphomas, and other diseases or health conditions.
- Other potential health effects include: irritation of the eyes and upper respiratory tract, headache, light-headedness, dizziness, confusion, drowsiness, nausea, vomiting, and occasionally abdominal pain.
- Eye contact: Immediately flush with water for at least 15 minutes and seek immediate medical attention.
- Skin Contact: Immediately wash with soap and water and seek immediate medical attention.
- Inhalation: Move the person to fresh air and seek immediate medical attention.
- Do not remove shields, covers, or safety features on equipment that is in use.
- Never place fingers, hands, or any body part near or directly in front of the spray gun fluid tip. The force of the liquid as it exits the spray tip can shoot liquid through the skin.
- Keep hands and body parts away from any moving equipment or components.
- Do not stand under plunger
- An improperly loaded drum may lead to an imbalance, causing a unit to tip over

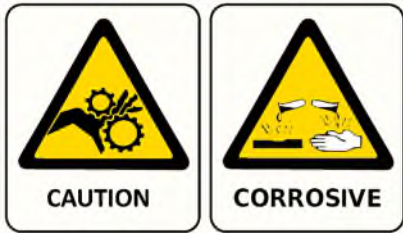

Personal Protective Equipment (PPE)

- MVP recommends the use of personal safety equipment with all products in our catalog.
- Wear safety goggles, hearing protection, a respirator, and chemical resistant gloves.
- Wear long sleeve shirts or jackets and pants to minimize skin exposure.
- PPE should be worn by operators and service technicians to reduce the risk of injury.



For Additional information, contact the Occupational Safety and Health Administration (OSHA). <https://www.osha.gov/about.html>

Symbol Definitions



Indicates the risk of contact with chemicals that are hazardous, which may lead to injury or death.



Indicates the risk of contact with voltage / amperage that may lead to serious injury or death.



Indicates that the materials being used are susceptible to combustion.



Indicates the risk of contact with moving components that may lead to serious injury or death.



Indicates that the system or component should be grounded before proceeding with use or repair.



Indicates the use of lit cigarettes or cigars is prohibited, because the materials being used are susceptible to combustion.



Indicates that the materials and/or the process being performed can lead to ignition and explosion.



A recommendation for the use of Personal Protective Equipment (PPE) before using or repairing the product.

Polymer Matrix Materials: Advanced Composites

Potential health hazards associated with the use of advanced composites can be controlled through the implementation of an effective industrial hygiene and safety program.

https://www.osha.gov/dts/osta/otm/otm_iii/otm_iii_1.html#t_iii:1_1

| Resins | | |
|--------------------------------------|--|---|
| Composite Component | Organ System Target (Possible Target) | Known (Possible) Health Effect |
| Epoxy resins | Skin, lungs, eyes | Contact and allergic dermatitis, conjunctivitis |
| Polyurethane resins | Lungs, skin, eyes | Respiratory sensitization, contact dermatitis, conjunctivitis |
| Phenol formaldehyde | Skin, lungs, eyes | As above (potential carcinogen) |
| Bismaleimides (BMI) | Skin, lungs, eyes | As above (potential carcinogen) |
| Polyamides | Skin, lungs, eyes | As above (potential carcinogen) |
| Reinforcing materials | | |
| Composite Component | Organ System Target (Possible Target) | Known (Possible) Health Effect |
| Aramid fibers | Skin (lungs) | Skin and respiratory irritation, contact dermatitis (chronic interstitial lung disease) |
| Carbon/graphite fibers | Skin (lungs) | As noted for aramid fibers |
| Glass fibers (continuous filament) | Skin (lungs) | As noted for aramid fibers |
| Hardeners and curing agents | | |
| Composite Component | Organ System Target (Possible Target) | Known (Possible) Health Effect |
| Diaminodiphenylsulfone | N/A | No known effects with workplace exposure |
| Methylenedianiline | Liver, skin | Hepatotoxicity, suspect human carcinogen |
| Other aromatic amines | | |
| Composite Component | Organ System Target (Possible Target) | Known (Possible) Health Effect |
| Meta-phenylenediamine (MPDA) | Liver, skin (kidney, bladder) | Hepatitis, contact dermatitis (kidney and bladder cancer) |
| Aliphatic and cyclo-aliphatic amines | Eyes, skin | Severe irritation, contact dermatitis |
| Polyaminoamide | Eyes, skin | Irritation (sensitization) |
| Anhydride | Eyes, lungs, skin | Severe eye and skin irritation, respiratory sensitization, contact dermatitis |

Catalyst - Methyl Ethyl Ketone Peroxide (MEKP)

MEKP is among the more hazardous materials found in commercial channels. The safe handling of the “unstable (reactive)” chemicals presents a definite challenge to the plastics industry. The highly reactive property which makes MEKP valuable to the plastics industry in producing the curing reaction of polyester resins also produces the hazards which require great care and caution in its storage, transportation, handling, processing and disposal. MEKP is a single chemical. Various polymeric forms may exist which are more or less hazardous with respect to each other. These differences may arise not only from different molecular structures (all are, nevertheless, called “MEKP”) and from possible trace impurities left from the manufacture of the chemicals, but may also arise by contamination of MEKP with other materials in its storage or use. Even a small amount of contamination with acetone, for instance, may produce an extremely shock-sensitive and explosive compound.



WARNING

Contamination with promoters, materials containing promoters (such as laminate sandings), or with any readily oxidizing material (such as brass or iron) will cause exothermic redox reactions which can be explosive in nature. Heat applied to MEKP or heat buildup from contamination reactions can cause the material to reach its Self-Accelerating Decomposition Temperature (SADT).

Researchers have reported measuring pressure rates-of-rise well over 100,000 psi per second when certain MEKP's reach their SADT. For comparison, the highest-pressure rate-of-rise listed in NFPA Bulletin NO.68, “Explosion Venting”, is 12,000 psi per second for an explosion of 12% acetylene and air. The maximum value listed for a hydrogen explosion is 10,000 psi per second. Some forms of MEKP, if allowed to reach their SADT, will burst even an open topped container. This suggests that it is not possible to design a relief valve to vent this order of magnitude of pressure rate-of-rise. The user should be aware that any closed container, be it a pressure vessel, surge chamber, or pressure accumulator, could explode under certain conditions. There is no engineering substitute for care by the user in handling organic peroxide catalysts. If, at any time, the pressure relieve valve on top of the catalyst tank should vent, the area should be evacuated at once and the fire department called. The venting could be the first indication of a heat, and therefore, pressure build-up that could eventually lead to an explosion. Moreover, if a catalyst tank is sufficiently full when the pressure relief valve vents, some catalyst may spray out, which could cause eye injury. For this reason, and many others, anyone whose job puts them in an area where this vented spray might go, should always wear full eye protection even when laminating operations are not taking place.

Safety in handling MEKP depends to a great extent on employee education, proper safety instructions, and safe use of the chemicals and equipment. Workers should be thoroughly informed of the hazards that may result from improper handling of MEKP, especially regarding contamination, heat, friction and impact. They should be thoroughly instructed regarding the proper action to be taken in the storage, use, and disposal of MEKP and other hazardous materials used in the laminating operation. In addition, users should make every effort to:

- Store MEKP in a cool, dry place in original containers away from direct sunlight and away from other chemicals.
- Keep MEKP away from heat, sparks, and open flames.
- Prevent contamination or MEKP with other materials, including polyester over spray and sandings, polymerization accelerators and promoters, brass, aluminum, and non-stainless steels.

- Never add MEKP to anything that is hot, since explosive decomposition may result.
- Avoid contact with skin, eyes, and clothing. Protective equipment should be worn at all times. During clean-up of spilled MEKP, personal safety equipment, gloves, and eye protection must be worn. Firefighting equipment should be at hand and ready.
- Avoid spillage, which can heat up to the point of self-ignition.
- Repair any leaks discovered in the catalyst system immediately, and clean-up the leaked catalyst at once in accordance with the catalyst manufacturer's instructions.
- Use only original equipment or equivalent parts from Magnum Venus Products in the catalyst system (i.e.: hoses, fitting, etc.) because a dangerous chemical reaction may result between substituted parts and MEKP.
- Catalyst accumulated from the purging of hoses or the measurement of fluid output deliveries should never be returned to the supply tank, such catalyst should be diluted with copious quantities of clean water and disposed of in accordance with the catalyst manufacturer's instructions.

The extent to which the user is successful in accomplishing these ends and any additional recommendations by the catalyst manufacturer determines largely the safety that will be present in his operation.

Clean-Up Solvents and Resin Diluents



WARNING

A hazardous situation may be present in your pressurized fluid system! Hydro carbon solvents can cause an explosion when used with aluminum or galvanized components in a closed (pressurized) fluid system (pump, heaters, filters, valves, spray guns, tanks, etc.). An explosion could cause serious injury, death, and/or substantial property damage. Cleaning agents, coatings, paints, etc. may contain Halogenated Hydrocarbon solvents. Some Magnum Venus Products spray equipment includes aluminum or galvanized components and will be affected by Halogenated Hydrocarbon solvents.

There are three key elements to the Halogenated Hydrocarbon (HHC) solvent hazard.

- | | | |
|----|---|--|
| 1. | The presence of HHC solvents. | 1,1,1 – Trichloroethane and Methylene Chloride are the most common of these solvents. However, other HHC solvents are suspect if used; either as part of paint or adhesives formulation, or for clean-up flushing. |
| 2. | Aluminum or Galvanized Parts. | Most handling equipment contains these elements. In contact with these metals, HHC solvents could generate a corrosive reaction of a catalytic nature. |
| 3. | Equipment capable of withstanding pressure. | When HHC solvent contact aluminum or galvanized parts inside a closed container such as a pump, spray gun, or fluid handling system, the chemical reaction can, over time, result in a build-up of heat and pressure, which can reach explosive proportions. When all three elements are present, the result can be an extremely violent explosion. The reaction can be sustained with very little aluminum or galvanized metal; any amount of aluminum is too much. |

- The reaction is unpredictable. Prior use of an HHC solvent without incident (corrosion or explosion) does NOT mean that such use is safe. These solvents can be dangerous alone (as a clean-up or flushing agent) or when used as a component or a coating material. There is no known inhibitor that is effective under all circumstances. Mixing HHC solvents with other materials or solvents such as MEKP, alcohol, or toluene may render the inhibitors ineffective.
- The use of reclaimed solvents is particularly hazardous. Reclaimers may not add any inhibitors. The possible presence of water in reclaimed solvents could also feed the reaction.
- Anodized or other oxide coatings cannot be relied upon to prevent the explosive reaction. Such coatings can be worn, cracked, scratched, or too thin to prevent contact. There is no known way to make oxide coatings or to employ aluminum alloys to safely prevent the chemical reaction under all circumstances.
- Several solvent suppliers have recently begun promoting HHC solvents for use in coating systems. The increasing use of HHC solvents is increasing the risk. Because of their exemption from many state implementation plans as Volatile Organic Compounds (VOCs), their low flammability hazard, and their not being classified as toxic or carcinogenic substances, HHC solvents are very desirable in many respects.

**WARNING**

Do not use Halogenated Hydrocarbon (HHC) solvents in pressurized fluid systems having aluminum or galvanized wetted parts. Magnum Venus Products is aware of NO stabilizers available to prevent HHC solvents from reaction under all conditions with aluminum components in closed fluid systems. HHC solvents are dangerous when used with aluminum components in a closed fluid system.

- Consult your material supplier to determine whether your solvent or coating contains Halogenated Hydrocarbon solvents.
- Magnum Venus Products recommends that you contact your solvent supplier regarding the best non-flammable clean-up solvent with the heat toxicity for your application.
- If, however, you find it necessary to use flammable solvents, they must be kept in approved, electrically grounded containers.
- Bulk solvent should be stored in a well-ventilated, separate building, 50 feet away from your main plant.
- You should only allow enough solvent for one day's use in your laminating area.
- NO SMOKING signs must be posted and observed in all areas of storage or where solvents and other flammable materials are used.
- Adequate ventilation (as covered in OSHA Section 1910.94 and NFPA No.91) is important wherever solvents are stored or used, to minimize, confine and exhaust the solvent vapors.
- Solvents should be handled in accordance with OSHA Section 1910.106 and 1910.107.

Catalyst Diluents

Magnum Venus Products spray-up and gel-coat systems currently produced are designed so that catalyst diluents are not required. Magnum Venus Products therefore recommends that diluents not be used to avoid possible contamination which could lead to an explosion due to the handling and mixing of MEKP and diluents. In addition, it eliminates any problems from the diluent being contaminated through rust particles in drums, poor quality control on the part of the diluents suppliers, or any other reason. If diluents are absolutely required, contact your catalyst supplier and follow his instructions explicitly. Preferably the supplier should premix the catalyst to prevent possible “on the job” contamination while mixing.



WARNING

If diluents are not used, remember that catalyst spillage and gun, hose, and packing leaks are potentially more hazardous since each drop contains a higher concentration of catalyst and will therefore react more quickly with overspray and the leak.

Cured Laminate, Overspray and Laminate Sandings Accumulation

- Remove all accumulations of overspray, Fiberglass Reinforced Plastic (FRP) sandings, etc. from the building as they occur. If this waste is allowed to build up, spillage of catalyst is more likely to start a fire; in addition, the fire would burn hotter and longer.
- Floor coverings, if used, should be non-combustible.
- Spilled or leaked catalyst may cause a fire if it comes in contact with an FRP product, oversprayed chop or resin, FRP sandings or any other material with MEKP.

To prevent spillage and leakage, you should:

- | | |
|--|---|
| 1. Maintain your Magnum Venus Products System. | Check the gun several times daily for catalyst and resin packing or valve leaks. REPAIR ALL LEAKS IMMEDIATELY. |
| 2. Never leave the gun hanging over or lying inside the mold. | A catalyst leak in this situation would certainly damage the part, possibly the mold, and may cause a fire. |
| 3. Inspect resin and catalyst hoses daily for wear or stress at the entry and exits of the boom sections and at the hose and fittings. | Replace if wear or weakness is evident or suspected. |
| 4. Arrange the hoses and fiberglass roving guides so that the fiberglass strands DO NOT rub against any of the hoses at any point. | If allowed to rub, the hose will be cut through, causing a hazardous leakage of material which could increase the danger of fire. Also, the material may spew onto personnel in the area. |

Toxicity of Chemicals

- Magnum Venus Products recommends that you consult OSHA Sections 1910.94, 1910.106, 1910.107 and NFPA No.33, Chapter 14, and NFPA No.91.
- Contact your chemical supplier(s) and determine the toxicity of the various chemicals used as well as the best methods to prevent injury, irritation and danger to personnel.
- Also determine the best methods of first aid treatment for each chemical used in your plant.

Equipment Safety

Magnum Venus Products suggest that personal safety equipment such as EYE GOGGLES, GLOVES, EAR PROTECTION, and RESPIRATORS be worn when servicing or operating this equipment. Ear protection should be worn when operating a fiberglass chopper to protect against hearing loss since noise levels can be as high as 116 dB (decibels). This equipment should only be operated or serviced by technically trained personnel!



CAUTION

Never place fingers, hands, or any body part near or directly in front of the spray gun fluid tip. The force of the liquid as it exits the spray tip can cause serious injury by shooting liquid through the skin. NEVER LOOK DIRECTLY INTO THE GUN SPRAY TIP OR POINT THE GUN AT OR NEAR ANOTHER PERSON OR AN ANIMAL.



DANGER

Contaminated catalyst may cause fire or explosion. Before working on the catalyst pump or catalyst accumulator, wash hands and tools thoroughly. Be sure work area is free from dirt, grease, or resin. Clean catalyst system components with clean water daily.



DANGER

Eye, skin, and respiration hazard. The catalyst MEKP may cause blindness, skin irritation, or breathing difficulty. Keep hands away from face. Keep food and drink away from work area.

Treatment of Chemical Injuries



CAUTION

Refer to your catalyst manufacturer's safety information regarding the safe handling and storage of catalyst. Wear appropriate safety equipment as recommended.

Great care should be used in handling the chemicals (resins, catalyst and solvents) used in polyester systems. Such chemicals should be treated as if they hurt your skin and eyes and as if they are poison to your body. For this reason, Magnum Venus Products recommends the use of protective clothing and eye wear in using polyester systems. However, users should be prepared in the event of such an injury.

Precautions include:

1. Know precisely what chemicals you are using and obtain information from your chemical supplier on what to do in the event the chemical gets onto your skin or into the eyes, or if swallowed.
2. Keep this information together and easily available so that it may be used by those administering first aid or treating the injured person.
3. Be sure the information from your chemical supplier includes instructions on how to treat any toxic effects the chemicals have.

**WARNING**

Contact your doctor immediately in the event of an injury. If the product's MSDS includes first aid instructions, administer first aid immediately after contacting a doctor.

Fast treatment of the outer skin and eyes that contact chemicals generally includes immediate and thorough washing of the exposed skin and immediate and continuous flushing of the eyes with lots of clean water for at least 15 minutes or more. These general instructions of first aid treatment may be incorrect for some chemicals; you must know the chemicals and treatment before an accident occurs. Treatment for swallowing a chemical frequently depends upon the nature of the chemical.

Emergency Stop Procedure

In an emergency, follow these steps to stop a system:

1. The ball valve located where the air enters the power head of the resin pump, should be moved to the "OFF" or closed position.

Note **The "open" or "on" position is when the ball valve handle is parallel (in line) with the ball valve body. The "closed" or "off" position is when the ball valve handle is perpendicular (across) the ball valve body.**

2. Turn all system regulators to the "OFF" position (counter-clockwise) position.
3. Verify / secure the catalyst relief line, located on the catalyst relief valve.
4. Verify / secure the resin return line, located on the resin filter.
5. Place a container under the resin pump ball valve to catch ejected resin.
6. Locate the ball valve on the resin pump.
7. Rotate the ball valve 90 degrees to the "On" or open position.

Grounding

Grounding an object means providing an adequate path for the flow of the electrical charge from the object to the ground. An adequate path is one that permits charge to flow from the object fast enough that it will not accumulate to the extent that a spark can be formed. It is not possible to define exactly what will be an adequate path under all conditions since it depends on many variables. In any event, the grounding means should have the lowest possible electrical resistance.

Grounding straps should be installed on all loose conductive objects in the spraying area. This includes material containers and equipment. Magnum Venus Products recommends grounding straps be made of AWG No.18 stranded wire as a minimum and the larger wire be used where possible. NFPA Bulletin No77 states that the electrical resistance of such a leakage path should be 1 meg ohm (10^6 ohms) or less.



CAUTION

Whenever flammable or combustible liquids are transferred from one container to another, or from one container to the equipment, both containers or container and equipment shall be effectively bonded and grounded to dissipate static electricity. For further information, see National Fire Protection Association (NFPA) 77, titled “Recommended Practice on Static Electrical”. Refer especially to section 7-7 titled “Spray Application of Flammable and Combustible Materials”.

Introduction

The MVP 3-Component Pro Gun is an air-trigger gun; meaning when an air signal is sent to the actuator, the actuator piston pushes on the actuator stem and rotates the gun block into the ON position. The gun works similarly to a dual ball valve, in that the valve rod rotates and the catalyst and resin holes line up with the ports in the gun block to allow material to flow. The actuator is an air cylinder, and as the piston moves back and forth, it rotates the valve rod 90 degrees to the ON position.

The 3-Component Pro Gun will not need to be completely disassembled for daily cleaning, however the entire gun should be disassembled and the O-rings and seals replaced every six months. The gun breaks down into four separate modules which can then be further disassembled into their individual parts. A special tool kit including a specially designed Pro Gun™ tool and a packing assembly tool is available to assist in performing maintenance and repair.

This manual provides information for the operation, maintenance, and simple repair of the MVP 3-Component Pro Gun. The following procedures are included:

- Step-by-step assembly and disassembly
- Troubleshooting



Please read this manual carefully and retain for future reference. Follow the steps in the order given, otherwise you may damage the equipment or injure yourself.

As you disassemble the equipment, lay out the components on a clean surface in the correct order and direction to assist in reassembly.

Gun Assemblies and Components

This manual covers the following Pro Gun assemblies:

- CP3-1000 3-Component Gun – Internal Mix
- CP3-2000 3-Component Gun – External Mix

Getting Started

Tools Needed

You will need the following to perform the maintenance detailed in this manual:

- Rubber mallet
- Thread sealant
- Adjustable wrench
- Needle-nose pliers
- Flat head screwdriver
- Lubriplate™ lubricant
- Scribe set
- Pro Gun oil
- Turbulent mixer puller
- Seal installation tool
- Alignment tool for resin seals
- Alignment tool for catalyst seals
- $\frac{5}{32}$ Hex wrench
- T15 TORX Bit
- Pro Gun screwdriver and packing bit

Note *CP-TOOLS-INT available from MVP contains the last 8 items on the list.*

Other Materials

You should also have appropriate cleaning materials available such as solvent, clean shop towels or rags, a small brush, and empty containers into which you can flush the gun.

You will need new O-rings and seals to replace the existing ones in the gun. Refer to the Parts Information to obtain proper part numbers for the O-rings and seals you are replacing.

Note *If you are using O-ring part number 01128 in the gun block, you only need to replace it when it is showing obvious signs of wear. This O-ring is specially designed to handle most solvents.*

Disconnecting from the Unit

Release System Pressure

1. Turn off air supply to the pumping system.

2. Release fluid pressure from lines by holding the gun over an appropriate waste container and pulling the trigger.
3. Flush the gun into an appropriate container.
4. Turn off air supply to the solvent tank.
5. Release any pressure in the flush tank by gently pulling the ring attached to the pressure relief valve.
6. Disconnect the air line from the rear of the gun handle.
7. Place an empty container under the ball valve located at the bottom of the filter assembly.
8. **Slowly** open the ball valve.

Note ***You can leave the valve open or close it once all the pressure has been released.***

Disable Catalyst Pump

Slave Arm Pumps

9. Perform this procedure if your unit has a slave arm catalyst pump:
 - Remove the quick pin from the top of the catalyst pump and upper slave arm.
 - Tilt the catalyst pump away from the resin pump until the catalyst pump is resting against the vertical connecting post.
 - Trap the catalyst pump's upper bearing block between the vertical connecting post and the quick pin.

Ultra Proportioning Systems (UPS)

10. Perform this procedure if you have UPS catalyst pump:
 - Remove the hairpin from the quick pin assembly.
 - Remove the quick pin assembly from the pivot link assembly.

Remove Hoses



WARNING

There may still be trapped fluids under pressure in the lines. Remove fittings slowly to allow any pressurized fluid to escape.



CAUTION

Wear appropriate eye protection. Pressurized fluids may cause eye injury.

11. Wrap a large rag or shop towel around the resin fitting and a wrench.

12. Use the wrench to loosen the fitting slowly until you can remove the resin hose from the fitting.
13. Use the same technique to remove the solvent hose and the catalyst hose.

Disassembling the Gun



WARNING

To prevent injury, be sure all air is disconnected from the gun and that all pressure has been relieved before attempting to remove the trigger guard. The bolt that secures the trigger guard to the air cylinder also serves as a plug for the end cap. Removing this bolt without relieving air pressure can result in injury.

1. Check to make sure all air is disconnected from the gun.
2. Check to make sure all pressure is relieved from the gun.
3. Disconnect the trigger guard by removing the screw securing the top of the trigger guard to the end cap on the gun's actuating cylinder.
4. Remove the trigger guard.

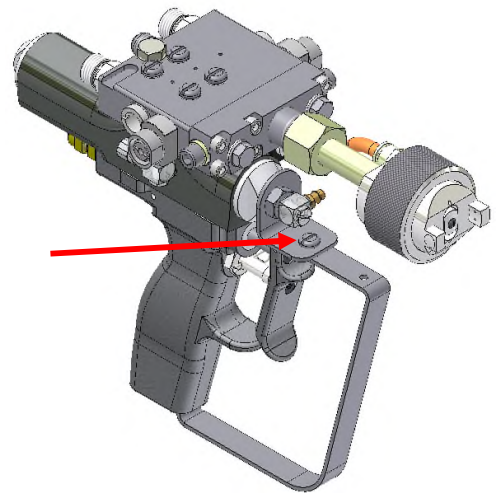

Disassemble into Modules

5. Remove the hex bolt and lock washer from the top of the gun block.
6. Remove the four screws and washers that secure the gun block to the actuator and remove the gun block.

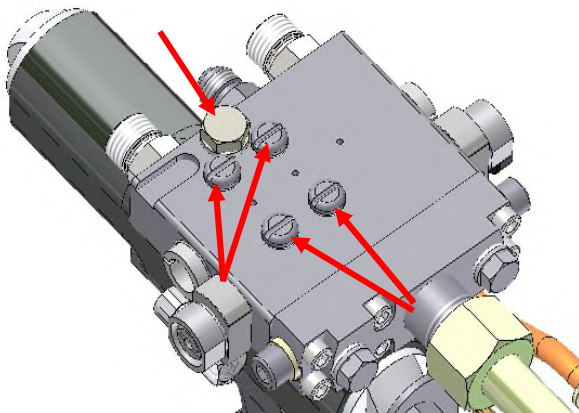

7. Set the gun block aside for now.
8. Remove the two mounting screws that secure the handle to the actuator and separate the two components.

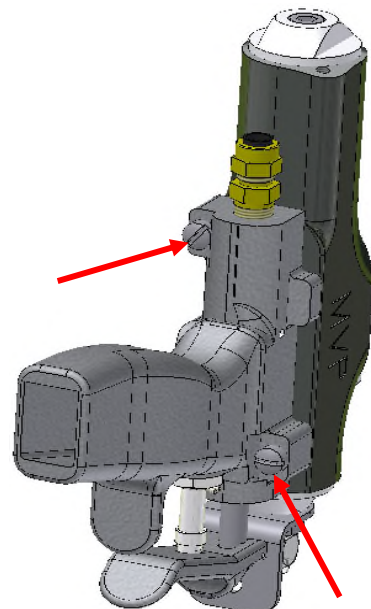

Disassemble Gun Block

Remove and Disassemble Flush Valve Assemblies

9. Unscrew both of the flush valve bodies from the gun block.

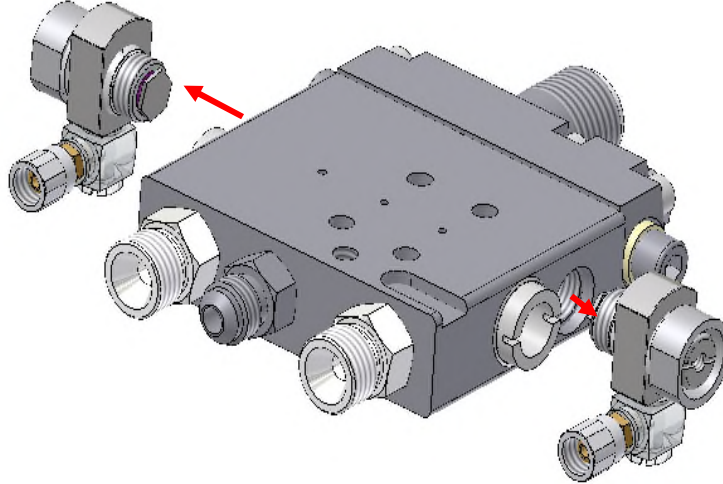

10. Remove the split seal from each flush valve body.

11. Remove each flush valve body from the flush valve neck.

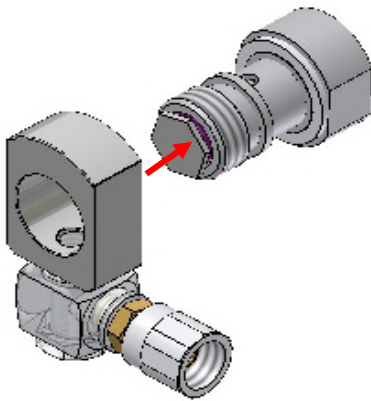
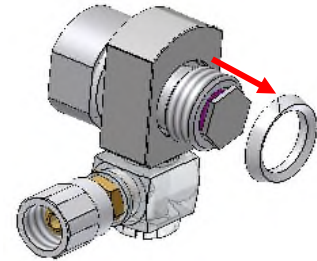

12. Remove each flush valve seal from each flush valve body.

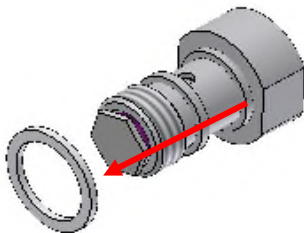

13. Remove the flush button assemblies from the flush valve bodies.

14. Unscrew each flush seal body from each flush valve button.

15. Remove each spring.

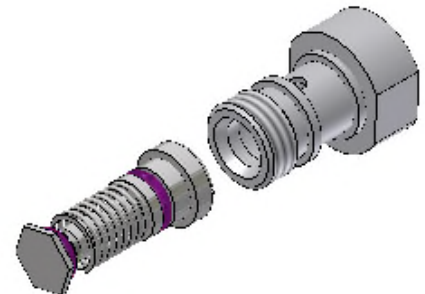

16. Use a scribe to remove both O-rings from the flush valve buttons.
17. Remove both O-rings from the flush seal bodies.

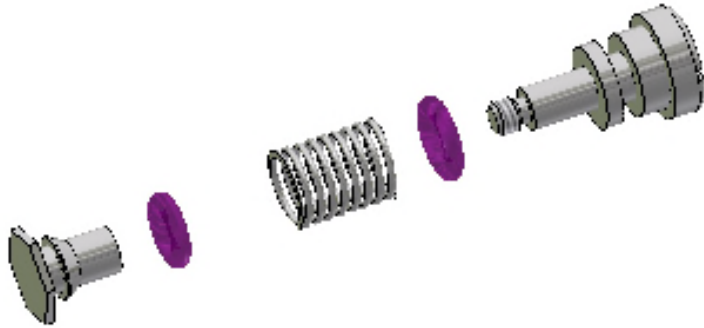

18. Set parts aside.
19. Discard and replace the flush valve O-rings and seals.

Note *The flush button O-ring (O-E-008) can be replaced by the O-K-008 O-ring designed for use with all solvents.*

Remove Mix Housing

20. Remove the two plugs and plug seals from the front of the mix housing.
21. Unscrew the cap screws holding the mix housing to the gun block and remove the mix housing.

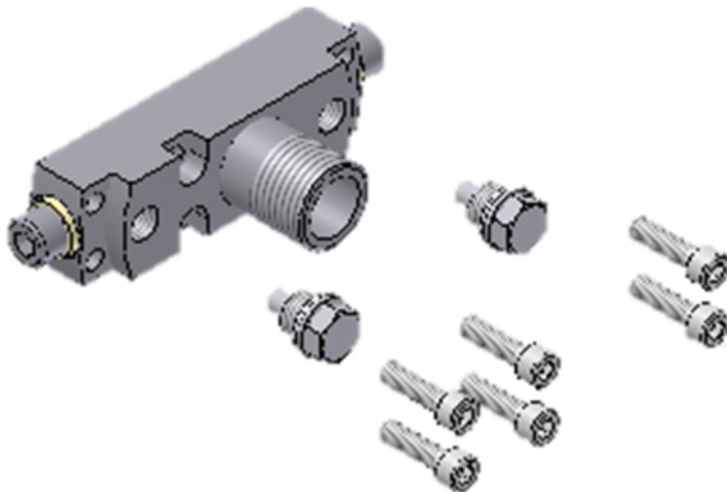

22. Pull the injector seal out and set the injector assembly aside.
23. Insert the turbulent mixer puller and give a slight twist to remove the turbulent mixer.

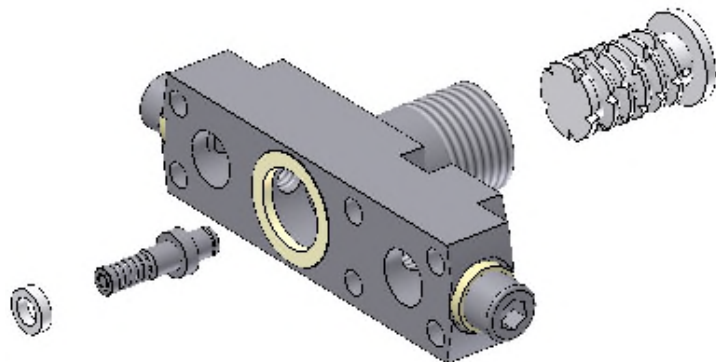

24. Use a blunt tool to push the distribution ring and housing seal out of the mix housing.

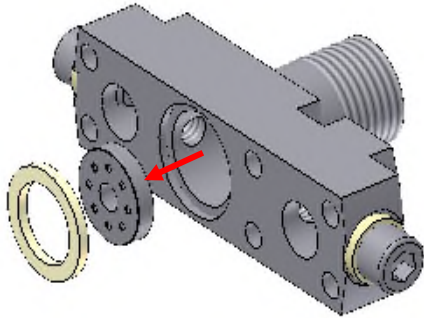

25. Inspect and clean the mix housing components with solvent.

Disassemble the Catalyst Injector Assembly

26. Unscrew the plunger retainer from the end of the injector plunger.
 27. Remove the spring.
 28. Remove the injector plunger from the injector body.

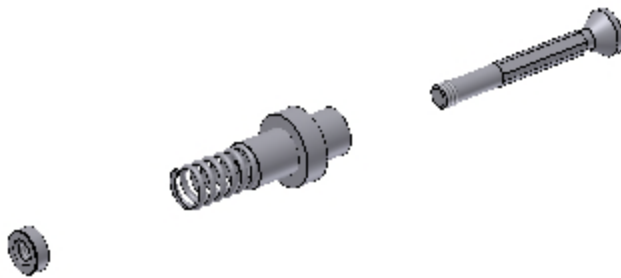

29. Inspect the plunger and the injector body for dirt or damage.
 30. Clean and reassemble.

Remove Hose Fittings

31. Remove and clean the catalyst fitting and O-ring on the rear of the gun block.
 32. Remove and clean the resin fitting and O-ring on the rear of the gun block.

Remove Actuating Stem

33. Tightly clamp the actuating stem into a soft-jawed vise and rotate the whole gun block to unscrew the actuating stem from the valve rod inside the gun block.

Note *Do not use the screwdriver slot in the end of the actuating stem for removal. If the slot becomes damaged, the stem will no longer fit into the actuator bushing. Make sure the actuating stem is smooth so that it does not wear out the actuator bushing.*

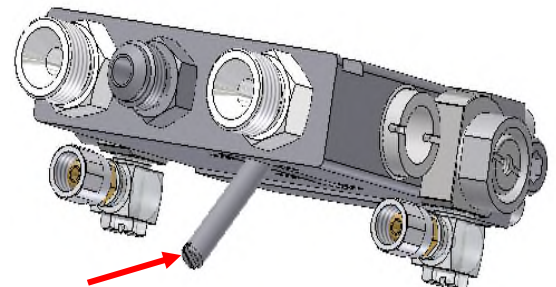

34. Remove the actuating stem.

Remove the Valve Rod

35. Use the magnetic handle and packing bit to unscrew the packing nuts from both the catalyst and resin side.

Note Use caution not to damage the packing bit. If you are unable to remove the packing nut, soak in solvent or apply heat to the packing nuts to loosen them.

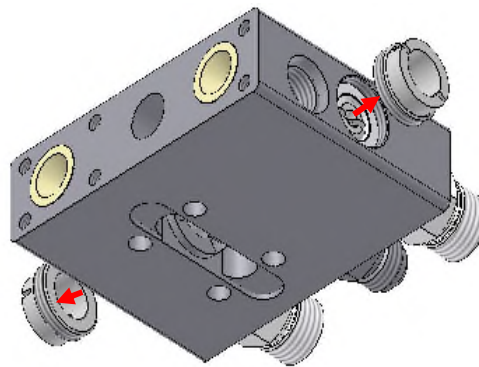
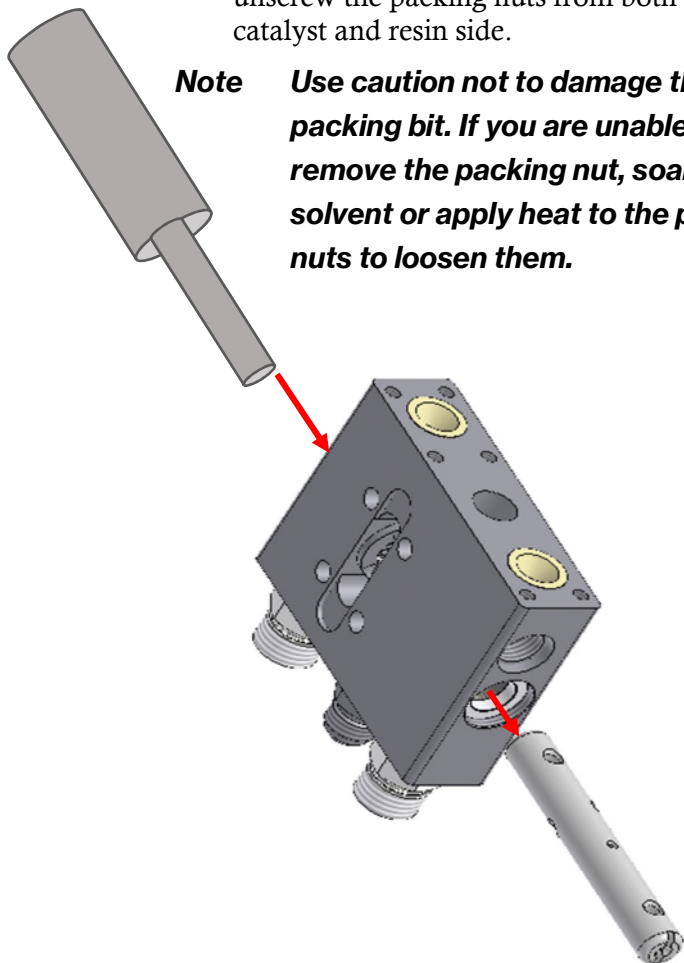

36. Place the small end of the seal installation tool onto one end of the valve rod.

37. Use a rubber mallet or rubber hammer to gently tap the valve rod out of the gun block.

38. Inspect the valve rod for damage and clean with solvent.

Remove Center Spacer

39. Use needle-nose pliers to remove the center spacer.

Remove Seals

40. Insert the seal installation tool into one of the side ports and gently tap it completely through the gun block with a rubber hammer or mallet.

As the tool is tapped through the interior of the gun block it removes the seal sets.

41. Remove the seals, relief spacers, packing rings, and secondary seals from the seal installation tool.

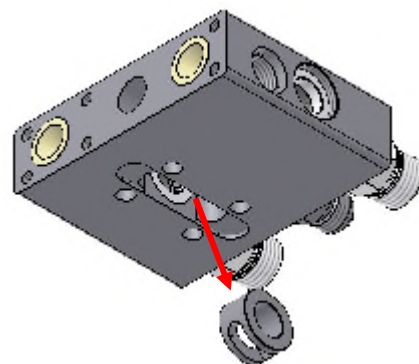

DANGER

Contaminated catalyst may cause fire or explosion. Keep the components of the catalyst side separate from the components of the resin side to avoid cross-contamination.

42. Clean the three relief spacers with solvent and allow to air dry.
43. Discard the seals and replace with new ones from the repair kit.

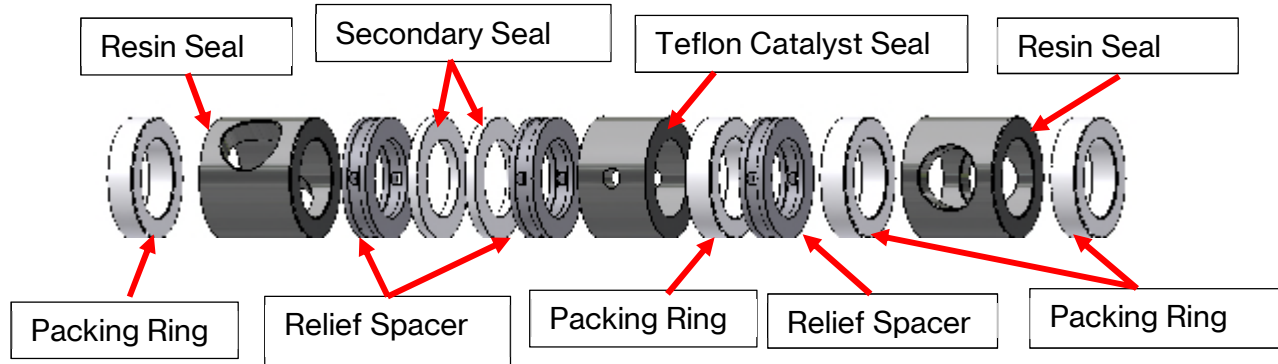

Reassembling Gun Block

Clean Gun Block

1. Discard O-rings and seals.
2. Clean remaining components with solvent and allow to air dry.

Install Secondary Seals

3. Place one of the secondary seals into the center of the gun block where the center spacer goes.
4. Gently push the secondary seal into position with something flat, flush with the gun block, using caution not to damage the seal.
5. Repeat steps [3](#) - [4](#) for the other secondary seal.

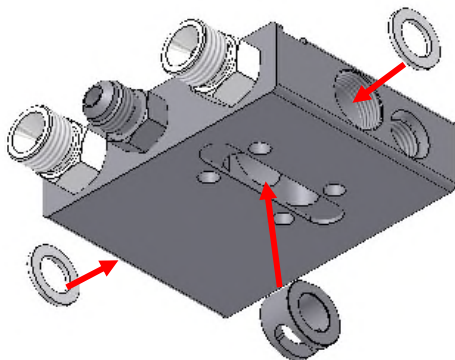

6. Place the center spacer in the gun block, making sure it is aligned as accurately as possible with the slot facing up.

Note ***Use caution not to damage the secondary seals previously installed.***

Reassemble Catalyst Side Components

7. Place the catalyst components onto the seal installation tool in the following order:

- Relief spacer
- Teflon catalyst seal
- Packing ring
- Relief spacer
- Packing ring
- Resin seal
- Packing ring

Note ***The hole in the catalyst seal should be aligned with the port in the gun block before inserting the seal installation tool into the gun block.***

8. Insert the seal installation tool with the components on it into the catalyst side of the gun block.
9. Press firmly (or tap with a rubber mallet), then pull the packing tool out of the gun block.
10. The components should be seated in the interior of the gun block against the center spacer.
11. Insert a packing nut, but do not tighten.

Align Seals

12. Hold the catalyst alignment tool (tapered drill bit) firmly with a pair of pliers.
13. Insert the catalyst alignment tool tapered end first into the gun block through the rear.
14. Gently press and move the alignment tool around until the holes in the catalyst seal align with the port in the gun block.

Reassemble Resin Side Components

15. Place the resin components for one side of the gun block onto the seal installation tool in the following order:

- Relief spacer
- Resin seal
- Packing ring

Note ***Before inserting the packing tool, align the hole in the resin seal with the hole in the gun block as closely as possible.***

16. Insert the seal installation tool into the resin side of the gun block.
17. Tap gently with a rubber hammer or mallet, then pull the packing tool out of the gun block.

Note ***The resin components should be seated in the interior of the gun block against the center spacer.***

18. Gently screw a packing nut into the resin side, but do not tighten.

Align Resin Seal

19. Hold the resin alignment tool (tapered drill bit) firmly with a pair of pliers.
 20. Insert the resin alignment tool tapered end first into the gun bloc through the rear.
 21. Gently move the resin alignment tool inside the gun block so that the holes in the resin seal align with the port in the gun block.

Note ***At this point, the resin side packing nut should only be hand tight.***

Install Valve Rod and Actuating Stem

22. Insert the valve rod into the gun block through the resin side, using a packing tool to center.

Note ***Make sure the valve rod is correctly aligned. The larger holes correspond to the resin seals and the smaller hole goes with the catalyst seal. The threaded hole, into which the actuating stem will be inserted, must also be correctly aligned to the center spacer. One end of the threaded hole has a relief that should face out of the gun block.***

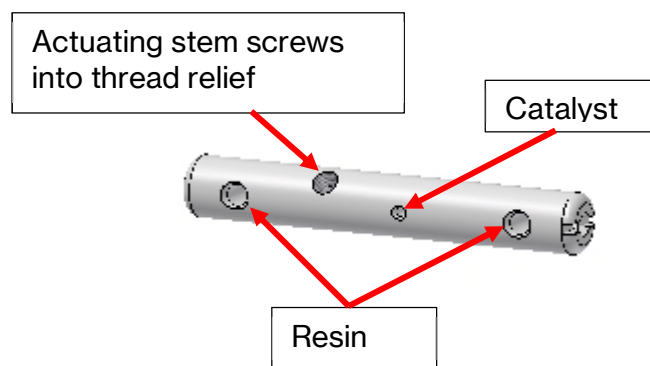

23. Screw the actuating stem into the valve rod through the center spacer.

Note ***Make sure the actuating stem is screwed into the side of the valve rod with the thread relief.***

24. Look down the front of the gun while moving the actuating stem back and forth and observe the holes opening and closing.
 25. Set the actuating stem so that the holes are closed.

Tighten Packing Nuts

26. Tighten both packing nuts, being careful not to damage the packing bit.
 27. Move the actuating stem back and forth, opening and closing the gun.
 28. Retighten both the packing nuts.
 29. Repeat steps [26](#) - [28](#) one more time.

Reinstall Fittings and Valves

30. Reinstall the fittings and O-rings for the resin hoses on the rear of the gun block.
31. Reinstall the catalyst fitting and O-ring on the rear of the gun block.

Reassemble Flush Valve

32. Place the O-rings on the flush valve buttons.
33. Insert the springs onto the flush valve buttons.
34. Push the button and spring into the flush valve bodies.
35. Place the O-rings on the flush seal bodies.
36. Insert a flush seal body into the end of the flush valve body and screw it onto the button.
37. Place a flush valve seal on the flush valve body.
38. Install the flush valve body into the flush valve neck.
39. Install the split seal onto the flush valve body.
40. Screw a flush valve assembly into the front side port on each side of the gun block.

Assemble Mix Housing

41. Install the distribution ring into the mix housing.

Note ***Make sure the distribution ring is positioned correctly with the chamfered edge of the hole facing away from the turbulent mixer and toward the gun block.***

Note ***Make sure the holes in the distribution ring are clean and free of debris or hardened material.***

42. Position the mix housing seal into the mix housing and adjust the distribution ring.
43. Insert the catalyst injector assembly and injector seal into the center hole of the distribution ring with the spring facing up.
44. Use the socket cap screws to attach the mix housing to the gun block.



WARNING

Screws and fasteners provided with the Pro Gun are specially designed for this equipment. Use only MVP replacement parts or warranty may be voided.

45. Insert the turbulent mixer into the mix housing.
46. Apply some red grease to the threads of the mix housing and nozzle cap for ease of removal later.
47. Install the nozzle into the nozzle cap.
48. Screw the nozzle and nozzle cap onto the mix housing.

Rebuilding Actuator

Disassemble Actuator

1. Remove the two elongated O-rings from the underside of the cylinder body.

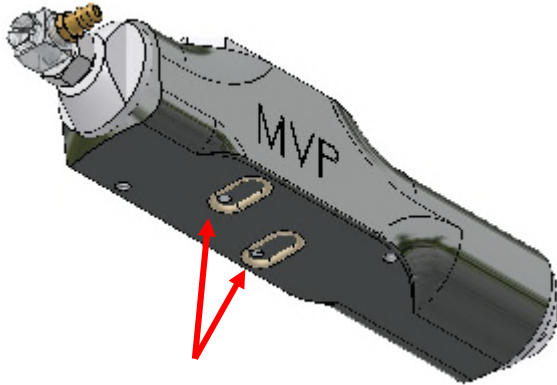

2. Unscrew the cylinder caps from each end of the cylinder body.

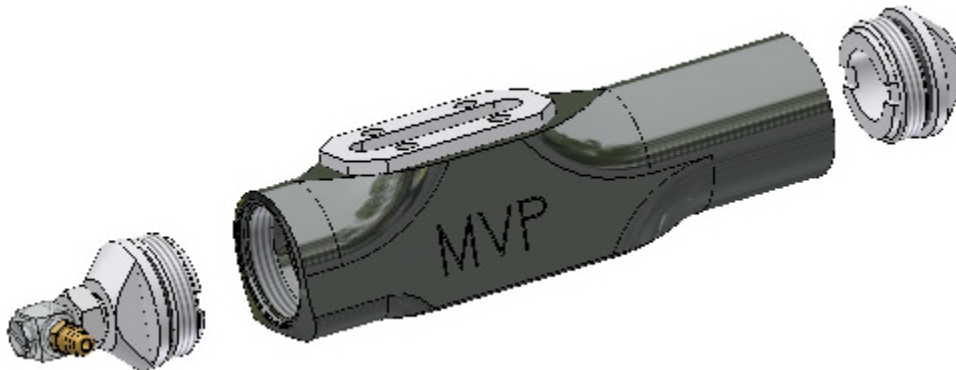

3. Remove the O-ring from each of the cylinder caps.
4. Remove the actuating piston by pushing it out the back end of the cylinder body with a blunt tool.

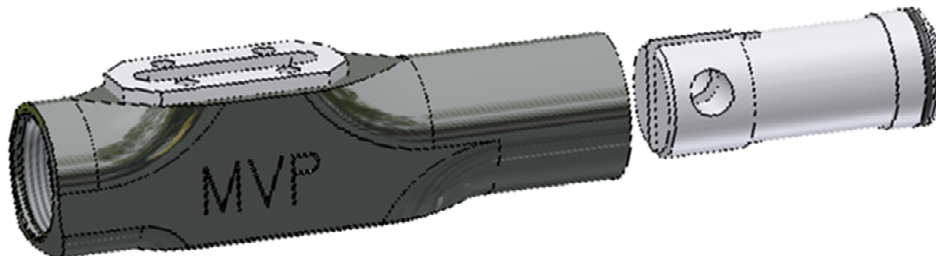

5. Use a scribe to remove the O-ring from the actuating piston, taking care to avoid damaging the actuating piston.

Note *Replace O-rings each time the gun is disassembled.*

6. Discard the used O-rings.
7. Remove the actuating bushing from the piston.
8. Clean the cylinder assembly components with solvent and allow to air dry.

Note *Do not soak actuating piston or cylinder caps in solvent; they will swell.*

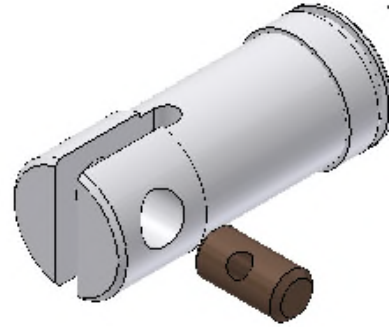

Assemble Actuator Cylinder

9. Place a new O-ring onto the actuating piston.
10. Insert the actuating bushing into the actuating piston.

Note *The hole in the actuating bushing must be facing up so the bushing hole can receive the actuating stem when the gun block is assembled.*

11. Use MVP Pro Gun Oil to lubricate the interior of the cylinder body and the actuating piston.
12. Insert the actuating piston into the cylinder body.

Note *Install the actuating piston into the cylinder so that the bushing is on the high side of the piston centerline. Use caution not to damage the O-ring on the piston while installing into the cylinder body.*

13. Place new O-rings in the grooves on the underside of the cylinder body.
14. Install a new O-ring on each of the cylinder caps.
15. Reinstall the two cylinder caps onto the cylinder body.

Rebuilding Gun Handle

Remove Trigger Assembly

1. Remove trigger locking hairpin.
2. Remove the fillister-head screw on the side.
3. Pull the trigger retainer and spool assembly from the gun handle interior.

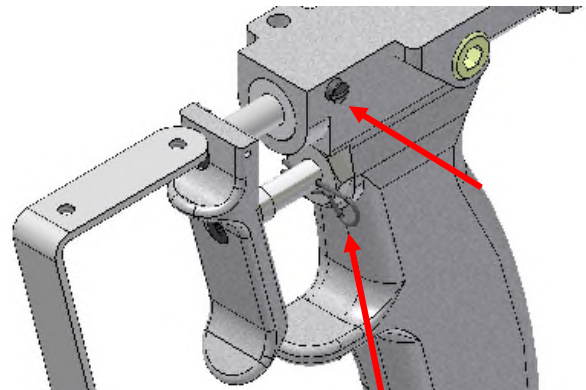

Disassemble Trigger Retainer

4. Remove the upper screw from the trigger.
5. Pull the trigger retainer off the spool assembly.
6. Remove the O-ring from inside the trigger spool retainer.

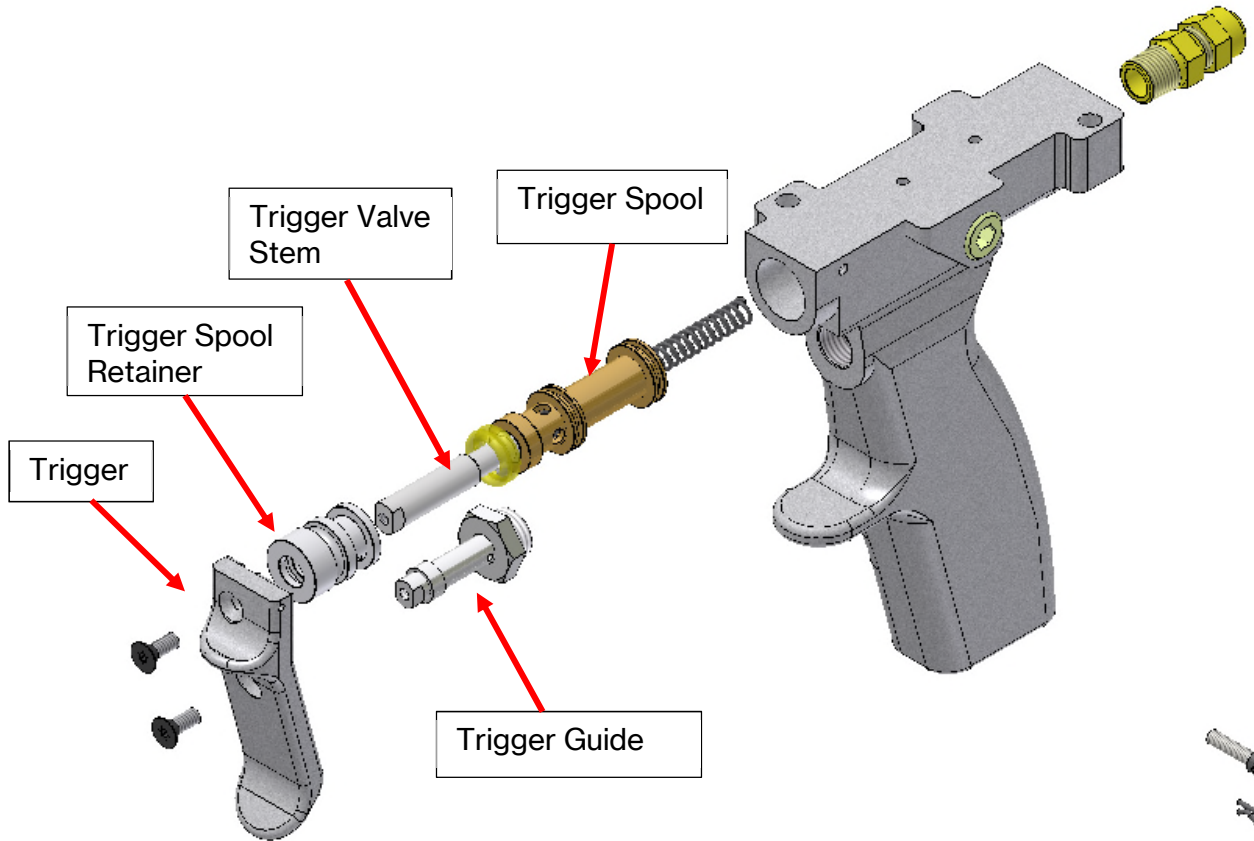

7. Remove the chrome ball in the trigger spool retainer by inserting a small scribe between the two O-rings and into each side of the retainer.

Note *Be careful not to drop the chrome balls located inside the trigger retainer. If your gun is used for gel coating, these balls will not be included.*

8. Remove the two O-rings on the trigger retainer.
9. Remove the two O-rings on the spool assembly.

Note *The spool assembly does not disassemble.*

10. Discard the used seals and O-rings and clean the remaining parts in solvent.

Assemble Gun Handle

Note *Refer to the drawing for your gun in the Parts Information section to obtain the correct parts numbers when reassembling.*

Replace O-rings and Seals

11. Discard used O-rings and seals and obtain new ones.
12. Reinstall the two O-rings on the spool assembly.
13. Lubricate the O-rings with Pro Gun oil.

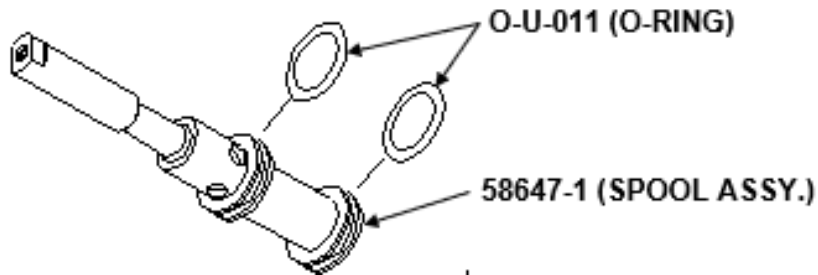

Reassemble Trigger Retainer

14. Place two O-rings in the external groove on the trigger retainer.

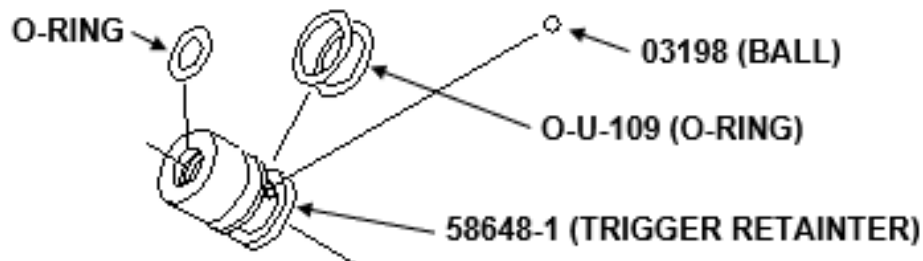

15. Insert a chrome ball into the spool assembly.
16. Grease the end of the spool assembly with Pro Gun oil.
17. Screw the spool assembly to the trigger using TORX screw.
18. Thoroughly lubricate the spool assembly and trigger retainer with MVP gun oil.

Attach Trigger Assembly to Handle

19. Insert the trigger assembly into the gun handle and secure with the fillister-head screw on the side of the handle.

Note *Be sure the front of the trigger retainer assembly is flush with the gun handle before installing screw.*

20. Install trigger hairpin as safety lock.

Optional Trigger and Spool Assembly

The conversion kit offers an alternative to the standard trigger and spool assemblies. The updated trigger is used in conjunction with the spool to provide a more durable design and eliminates the need for one of the screws in the end of the trigger.

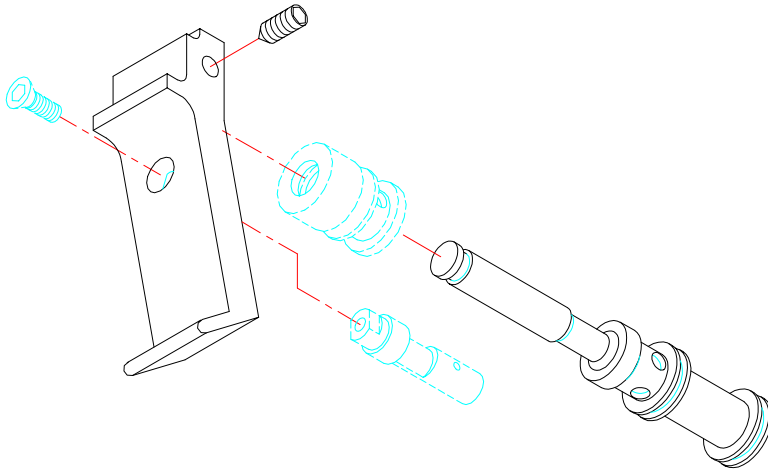

Reassembling Gun

1. Use the two mounting screws to secure the handle assembly to the actuator assembly.

Note *The hole in the actuating bushing must be facing up so that the bushing hole can receive the actuating stem of the gun block.*

2. Using the four mounting screws, secure the gun block to the actuator.

Note *The actuating stem must be in the hole of the actuator bushing. If you are unsure, remove the front endcap of the actuator and look.*

Parts Information

The following drawings are included to show the full assemblies for the various configurations of guns:

| Parts Drawings | |
|----------------|-------------------------------|
| Part Number | Description |
| CP3-1000 | 3-COMPONENT GUN INTERNAL MIX |
| CP3-2000 | 3-COMPONENT GUN EXTERNAL MIX |
| CP3-1100 | 3-COMPONENT GUN BLOCK |
| CP3-1100-E | 3-COMPONENT GUN BLOCK |
| CP3-1400 | GUN HEAD ASSEMBLY |
| 58604-1-S | ACTUATOR ASSEMBLY WITH SIGNAL |
| 58603-3 | PRO GUN HANDLE ASSEMBLY – GEL |
| VPA-1000 | AIR ASSIST ASSEMBLY |
| CP3-1000-RK | REPAIR KIT – PRO DUO GUN |
| CP3-2000-RK | REPAIR KIT – PRO DUO GUN |

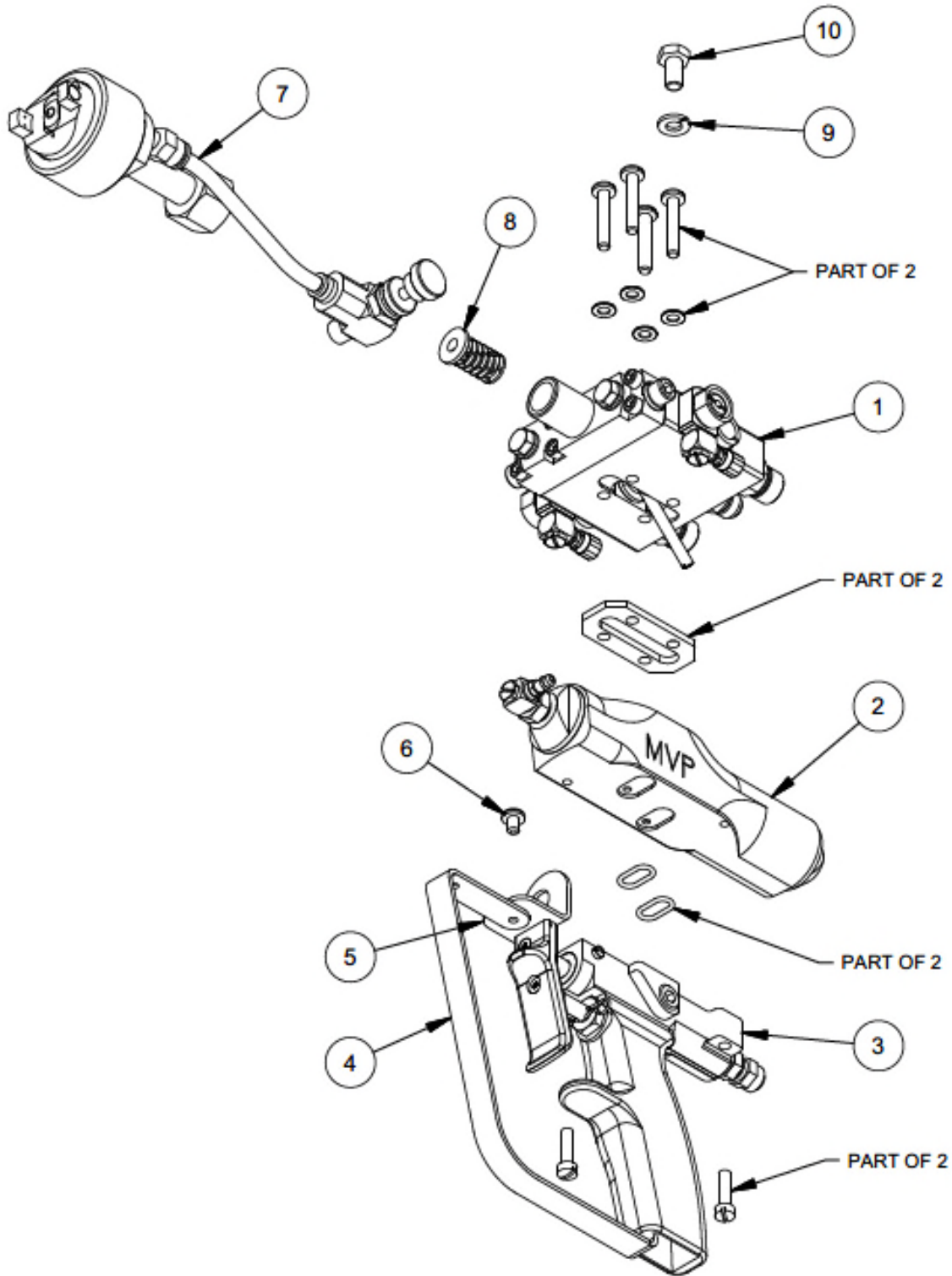

MAGNUM VENUS PLASTECH

THREE COMPONENT GUN - INTERNAL MIX

CP3-1000

REV:

SHEET 1 / 2

5/15/2015

| Parts List | | | |
|------------|-------------|-----|--------------------------------|
| ITEM | PART NUMBER | QTY | DESCRIPTION |
| 1 | CP3-1100 | 1 | GUN BLOCK 3 COMPONENT |
| 2 | 58604-1-S | 1 | GUN ACTUATOR ASSY |
| 3 | 58603-3 | 1 | CLASSIC PRO HANDLE ASSY. - GEL |
| 4 | 58670-1 | 1 | TRIGGER GUARD |
| 5 | 58671-1 | 1 | DRIP SHIELD |
| 6 | 02806-2 | 1 | 10-24 PAN HEAD SCREW |
| 7 | VPA-1000 | 1 | AIR ASSIST ASSEMBLY |
| 8 | 5107-27-2 | 1 | TURBULENT MIXER |
| 9 | F-SW-04 | 1 | LOCK WASHER |
| 10 | F-HB-04C-08 | 1 | HEX BOLT |

REPAIR KIT

CP3-1000-RK - INCLUDES PARTS FROM THE CP3-1100, VPA-1000,
58603-3, 58604-1-S

MAGNUM VENUS PLASTECH

THREE COMPONENT GUN - INTERNAL MIX

CP3-1000

REV:

SHEET 2 / 2

5/15/2015

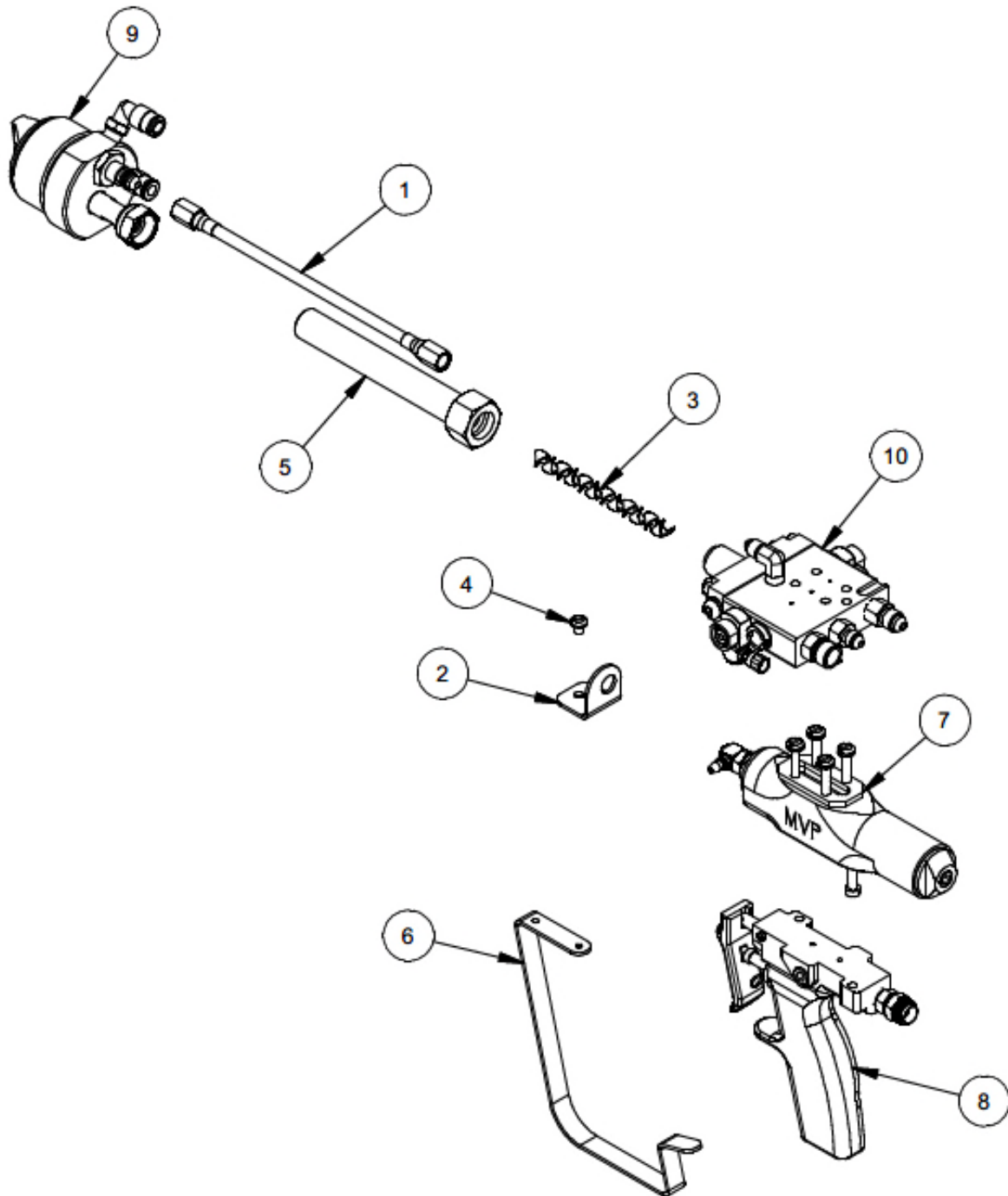

MAGNUM VENUS PLASTECH

3 COMPONENT GUN - EXTERNAL MIX

CP3-2000

REV:08-14-08 BT2

| Parts List | | | |
|------------|----------------|-----|--------------------------------|
| ITEM | PART NUMBER | QTY | DESCRIPTION |
| 1 | HCSS-0203J-8IN | 1 | HOSE ASSEMBLY |
| 2 | 58671-1 | 1 | DRIP SHIELD |
| 3 | 05244 | 1 | MIXER |
| 4 | 02806-2 | 1 | 10-24 PAN HEAD SCREW |
| 5 | 50056-1 | 1 | EXTENSION |
| 6 | 58670-1 | 1 | TRIGGER GUARD |
| 7 | 58604-1-S | 1 | GUN ACTUATOR ASSY |
| 8 | 58603-3 | 1 | CLASSIC PRO HANDLE ASSY. - GEL |
| 9 | CP3-1400 | 1 | GUN HEAD ASSEMBLY |
| 10 | CP3-1100-E | 1 | GUN BLOCK ASSY-EXTERNAL MIX |

REPAIR KIT - CP3-2000-RK - CONTAINS PARTS FROM THE CP3-1100-E,
CP3-1400, 58603-3, AND 58604-1-S

MAGNUM VENUS PLASTECH

3 COMPONENT GUN - EXTERNAL MIX

CP3-2000

REV:08-14-08 BT2

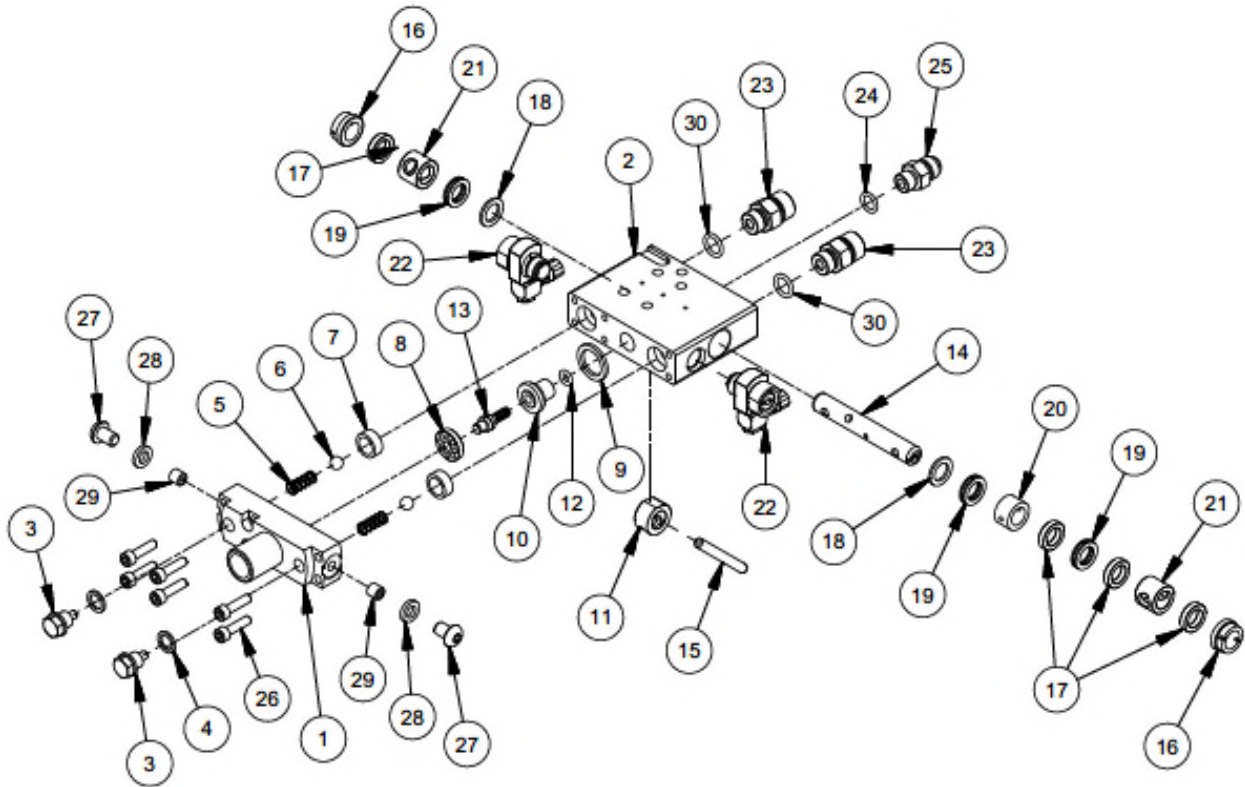

MAGNUM VENUS PLASTECH

| | |
|-----------------------|----------|
| GUN BLOCK 3 COMPONENT | CP3-1100 |
|-----------------------|----------|

REV:

SHEET 1 / 2

5/13/2015

| Parts List | | | |
|------------|-----------------|-----|-----------------------|
| ITEM | PART NUMBER | QTY | DESCRIPTION |
| 1 | CP3-1014 | 1 | MIX HOUSING |
| 2 | CP3-1013 | 1 | GUN BLOCK |
| 3 | 58696-1 | 2 | PLUG |
| 4 | 58695-1 | 2 | PLUG SEAL |
| 5 | 04319 | 2 | COMPRESSION SPRING |
| 6 | 03199 | 2 | SS BALL |
| 7 | 58694-1 | 2 | CHECK FACE SEAL |
| 8 | 5104-17-1 | 1 | DISTRIBUTION RING |
| 9 | CP3-1012 | 1 | MIX HOUSING SEAL |
| 10 | CP3-1010 | 1 | INJECTOR BUSHING |
| 11 | 5104-10-1 | 1 | CENTER SPACER |
| 12 | O-S-008 | 1 | O-RING SILICONE |
| 13 | 5104-03-01 | 1 | INJECTOR ASSY |
| 14 | CP3-1015 | 1 | VALVE ROD |
| 15 | 5104-11-1 | 1 | ACTUATING STEM |
| 16 | 5104-8-1 | 2 | PACKING NUT |
| 17 | 5104-7-1 | 4 | PACKING RING |
| 18 | 5104-3-1 | 2 | SECONDARY SEAL |
| 19 | 5104-4-1 | 3 | RELIEF SPACER |
| 20 | 5104-6-1 | 1 | TEFLON CATALYST SEAL |
| 21 | 5104-5-1 | 2 | RESIN SEAL |
| 22 | 5104-01-01 | 2 | FLUSH ASSEMBLY |
| 23 | 5104-9-1 | 2 | RESIN FITTING |
| 24 | O-S-3-903 | 1 | O-RING |
| 25 | 5104-27-1 | 1 | CONNECTOR FITTING |
| 26 | F-CS-832-10-GR8 | 6 | SOCKET HEAD CAP SCREW |
| 27 | F-BHCS-04C-06 | 2 | BUTTON HEAD CAP SCREW |
| 28 | 02441-1 | 2 | SEAL - GUN HEAD PLUG |
| 29 | 58752-4 | 2 | FLOW RESTRICTOR |
| 30 | O-E-3-904 | 2 | O-RING |

MAGNUM VENUS PLASTECH

GUN BLOCK 3 COMPONENT

CP3-1100

REV:

SHEET 2 / 2

5/13/2015

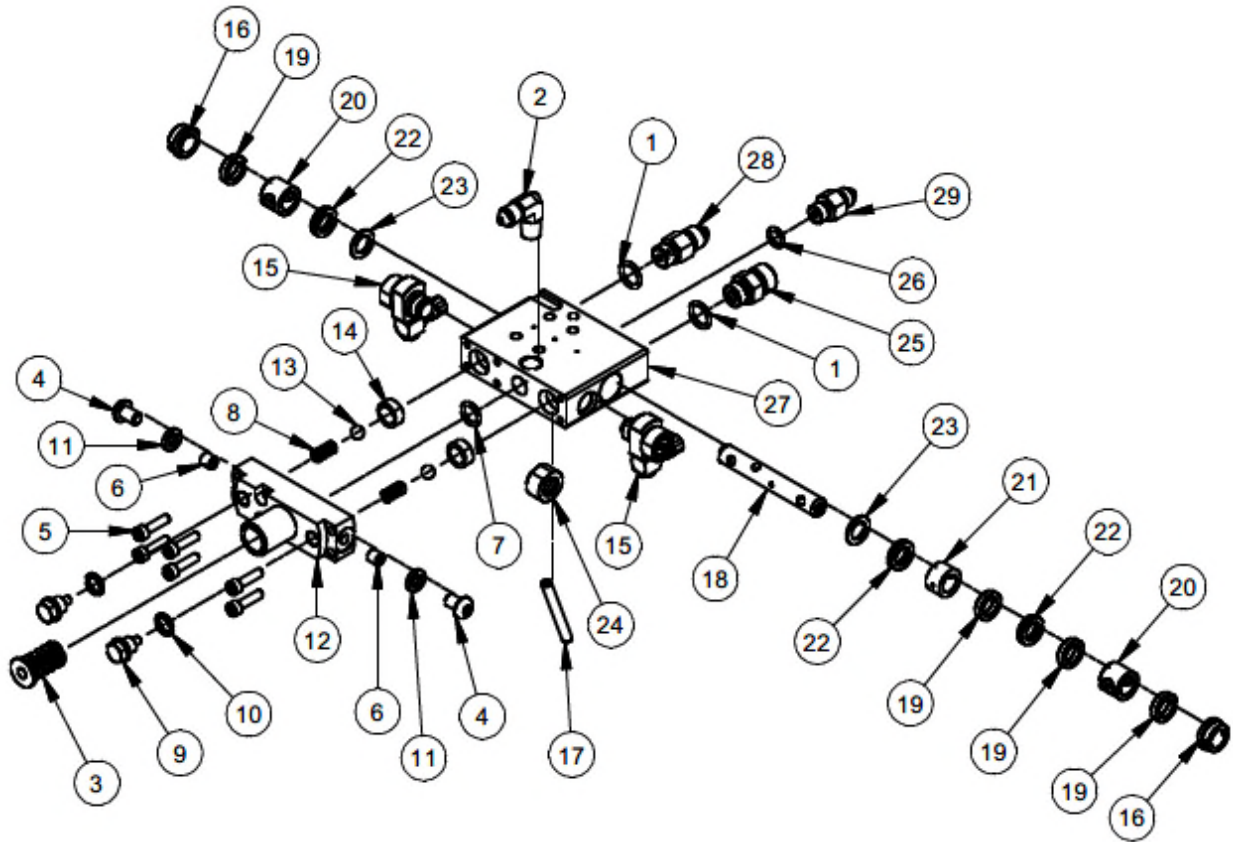

MAGNUM VENUS PLASTECH

3 COMPONENT GUN BLOCK

CP3-1100-E

REV:02-18-08

| Parts List | | | |
|------------|-----------------|-----|-----------------------|
| ITEM | PART NUMBER | QTY | DESCRIPTION |
| 29 | 7701-3-6 | 1 | CONNECTOR FITTING |
| 28 | HF-07F-04J-SS | 1 | HOSE FITTING |
| 27 | CP3-1017 | 1 | GUN BLOCK |
| 26 | O-S-3-903 | 1 | SILICONE O-RING |
| 25 | 5104-9-1 | 1 | RESIN FITTING |
| 24 | 5104-10-1 | 1 | CENTER SPACER |
| 23 | 5104-3-1 | 2 | SECONDARY SEAL |
| 22 | 5104-4-1 | 3 | RELIEF SPACER |
| 21 | 5104-6-1 | 1 | TEFLON CATALYST SEAL |
| 20 | 5104-5-1 | 2 | RESIN SEAL |
| 19 | 5104-7-1 | 4 | PACKING RING |
| 18 | CP3-1015 | 1 | VALVE ROD |
| 17 | 5104-11-1 | 1 | ACTUATING STEM |
| 16 | 5104-8-1 | 2 | PACKING NUT |
| 15 | 5104-01-01 | 2 | FLUSH ASSEMBLY |
| 14 | 58694-1 | 2 | CHECK FACE SEAL |
| 13 | 03199 | 2 | .25 DIA SS BALL |
| 12 | CP3-1018 | 1 | MIX HOUSING |
| 11 | 02441 | 2 | SEAL - GUN HEAD PLUG |
| 10 | 58695-1 | 2 | PLUG SEAL |
| 9 | 58696-1 | 2 | PLUG |
| 8 | 04319 | 2 | COMPRESSION SPRING |
| 7 | O-S-012 | 1 | O-RING |
| 6 | 58752-4 | 2 | FLOW RESTRICTOR |
| 5 | F-CS-832-10-GR8 | 6 | CAP SCREW |
| 4 | F-BHCS-04C-06 | 2 | BUTTON HEAD CAP SCREW |
| 3 | 5107-27-2 | 1 | TURBULENT MIXER |
| 2 | PF-ME-02-03J-SS | 1 | MALE ELBOW |
| 1 | O-E-3-904 | 2 | O-RING |

MAGNUM VENUS PLASTECH

3 COMPONENT GUN BLOCK

CP3-1100-E

REV:02-18-08 BT2

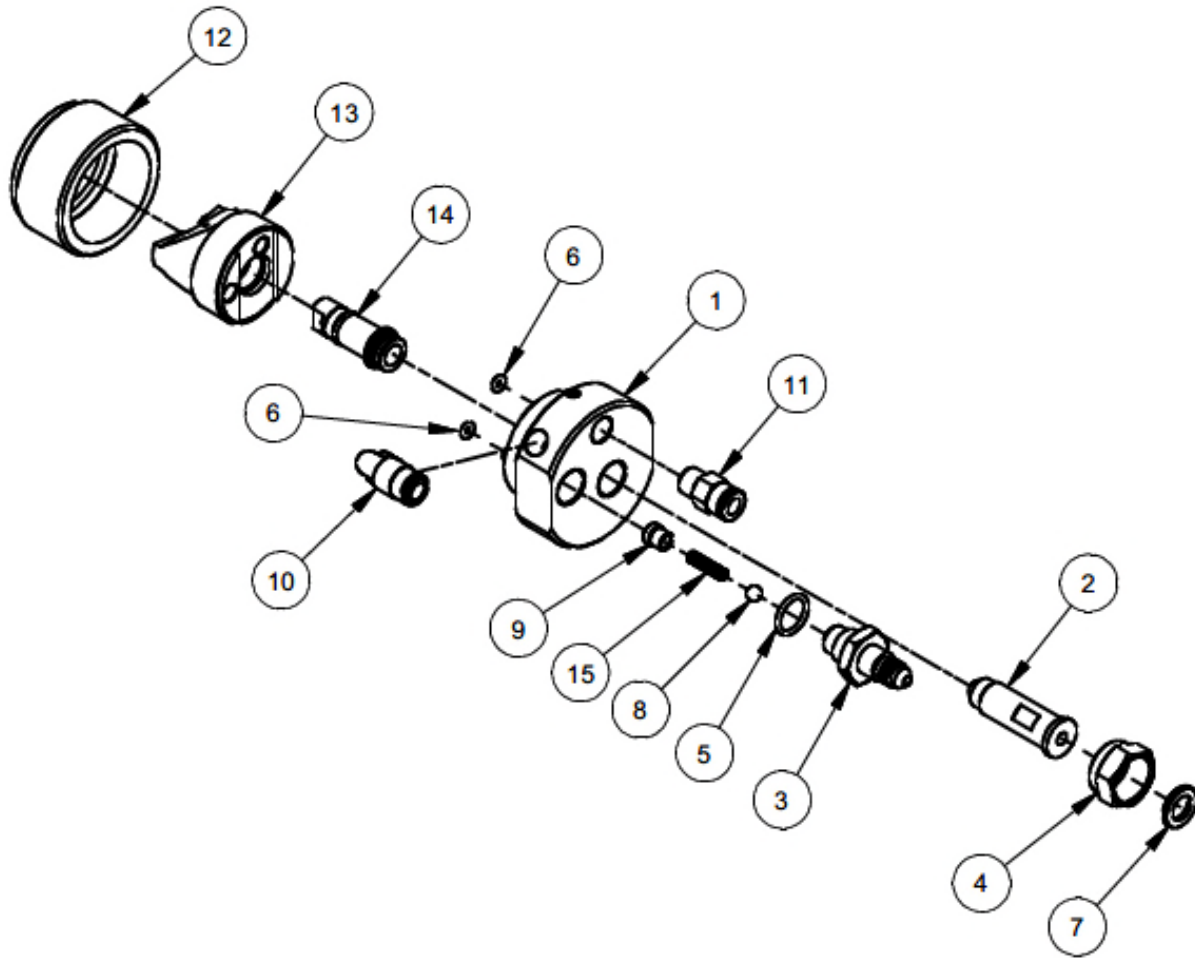

MAGNUM VENUS PLASTECH

GUN HEAD ASSEMBLY

CP3-1400

REV:02-19-08 BT2

| Parts List | | | |
|------------|---------------|-----|------------------------|
| ITEM | PART NUMBER | QTY | DESCRIPTION |
| 1 | CP3-1022 | 1 | GUN HEAD BODY ASSY |
| 2 | CP3-1016 | 1 | GUN HEAD CONNECTOR |
| 3 | CP3-1021 | 1 | CHECK VALVE BODY |
| 4 | 8704-4-1 | 1 | NOZZLE CAP |
| 5 | O-S-014 | 1 | O-RING |
| 6 | O-S-006 | 2 | O-RING |
| 7 | 02030-1 | 1 | SEAL |
| 8 | 9201-1-7 | 1 | SS BALL |
| 9 | 4101-17-1 | 1 | SPRING RETAINER |
| 10 | MPH-2539 | 1 | MALE ELBOW |
| 11 | 07223 | 1 | MALE CONNECTOR |
| 12 | MG-1018-CL-PL | 1 | DELTRIN RETAINING RING |
| 13 | UCT-35402 | 1 | CATALYST TIP |
| 14 | UCT- 521 | 1 | SPRAY TIP |
| 15 | 4101-16-1 | 1 | COMPRESSION SPRING |

MAGNUM VENUS PLASTECH

GUN HEAD ASSEMBLY

CP3-1400

REV:02-19-08 BT2

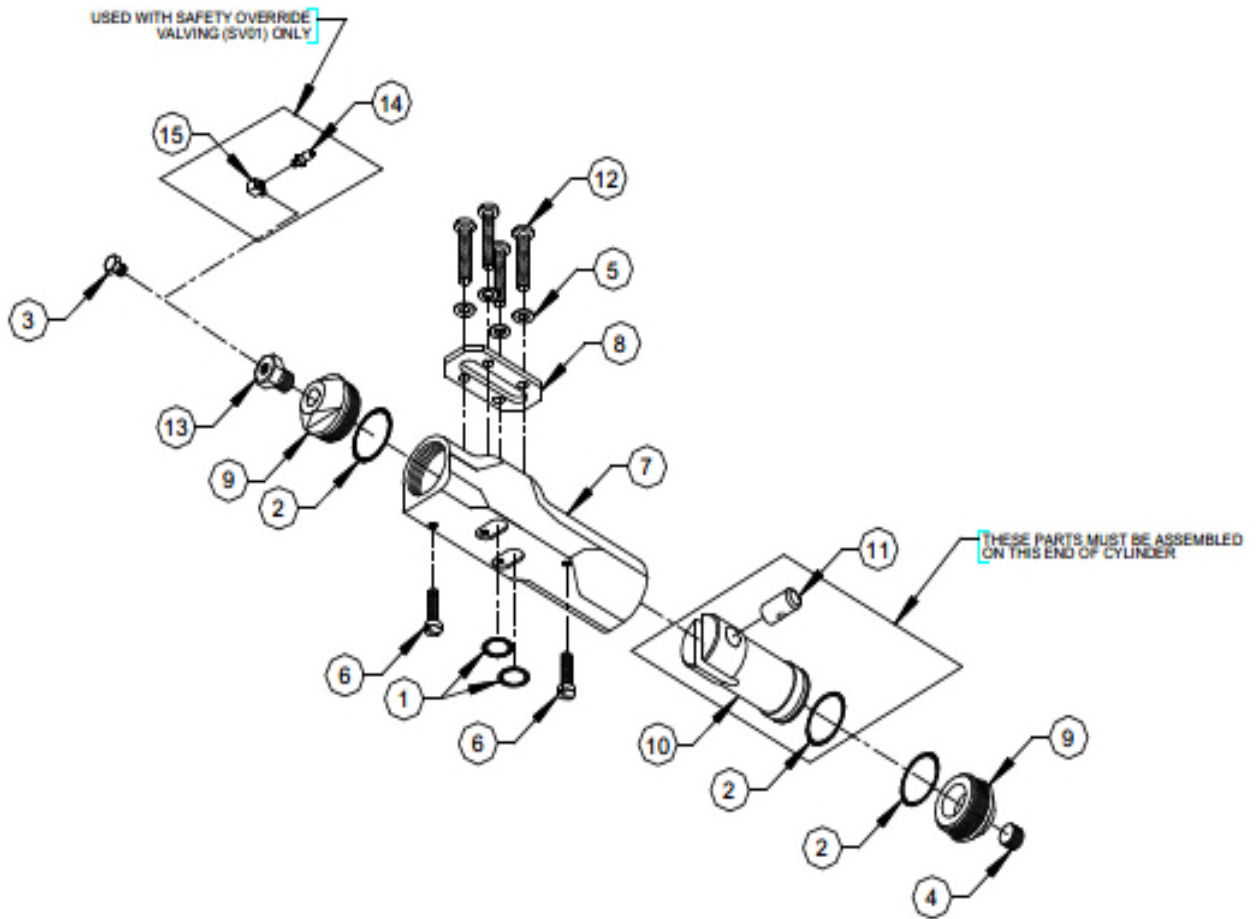

MAGNUM VENUS PLASTECH

Pro Series Gun Actuator Assembly

58604-1

Pro Series Gun Actuator Assembly with Signal

58604-1-S

REV. A = ADDED 58604-1-S ACTUATOR TO DRAWING 09/14/05
REV. B = UPDATED ITEMS 1, 2, AND 3 TO ALPHA-NUMERIC, ITEM 14 WAS 7701-6-7 03/28/08 BT2

Pro Series Gun Actuator Assembly 58604-1

COMMON PARTS LIST

| ITEM | PART NO. | QTY | DESCRIPTION |
|------|----------|-----|--------------------|
| 1 | O-V-013 | 2 | O-RING |
| 2 | O-V-020 | 3 | O-RING |
| 4 | PF-AP-02 | 1 | 1/8" PIPE PLUG |
| 5 | 5106-3-1 | 4 | MOUNTING SEAL |
| 6 | 58626-1 | 2 | MOUNTING SCREW |
| 7 | 58631-1 | 1 | CYLINDER BODY ASSY |
| 8 | 5106-2-1 | 1 | ACTUATOR SEAL |
| 9 | 5106-4-1 | 2 | CYLINDER CAP |
| 10 | 5106-7-1 | 1 | ACTUATING PISTON |
| 11 | 5106-5-1 | 1 | BUSHING |
| 12 | 5106-6-1 | 4 | MOUNTING SCREW |
| 13 | 5102-2-1 | 1 | SCREW - TRIGGER |

Actuator Assembly 58604-1

| ITEM | PART NO. | QTY | DESCRIPTION |
|------|----------|-----|---------------|
| 3 | 7701-4-6 | 1 | HEX HEAD PLUG |

Actuator Assembly w/ Signal 58604-1-S

| ITEM | PART NO. | QTY | DESCRIPTION |
|------|----------|-----|----------------|
| 14 | 7701-6-3 | 1 | BARBED FITTING |
| 15 | 7701-6-1 | 1 | ELBOW |

FIGURE 1-1

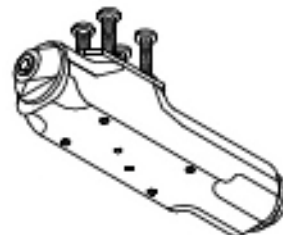

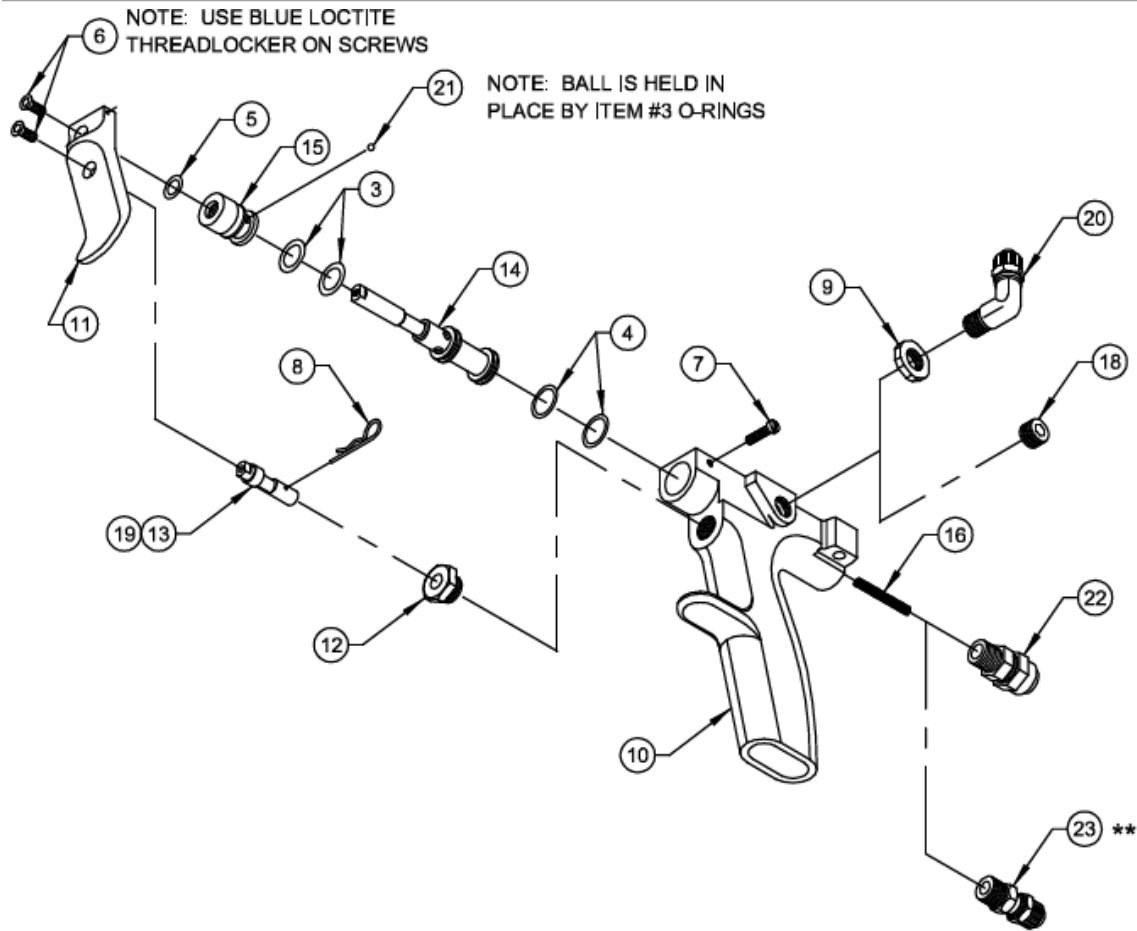

NOTE: ITEM 21 MAY BE REMOVED ON GUNS WHEN STAGED TRIGGER IS NOT DESIRED (GELCOAT, WETOUT)

** NOTE: ITEM 23 IS INCLUDED FOR EXISTING GELCOAT AND WETOUT GUNS THAT USE 6504-1-0.5 1/4" POLY WHIP, AS WELL AS CPD GUNS WITH NO WHIP. NEW GELCOAT AND WETOUT GUNS USE 6506-1-0.5 3/8" POLY WHIP

MAGNUM VENUS PLASTECH

| | |
|--|---------|
| Chopper Handle Assembly - Pro Gun | 58603-1 |
| Gelcoat / Wetout Handle Assembly - Pro Gun | 58603-3 |

REV. H = ADDED NOTE FOR ITEM 21, ADDED CPG-1007-CK TO OPTIONAL EQUIPMENT 04/28/09 BT2
 REV. I = ADDED ITEMS 12A AND 13A TO OPTIONAL EQUIPMENT 01/25/11 BT2
 REV. J = ITEM 4 WAS O-U-012 05/09/11 BT2
 REV. K = ADDED ITEM 22 TO 58603-3 GELCOAT HANDLE ASSEMBLY, ADDED NOTE FOR ITEM 23 FOR EXISTING GUNS 03/28/18 BT2

Common Assembly Parts For
Chopper Handle Assy - Pro Gun 58603-1
Gelcoat / Wetout Handle Assy - Pro Gun 58603-3

PARTS LIST

| ITEM | PART NO. | QTY | DESCRIPTION |
|------|-------------|-----|------------------------------|
| 3 | O-U-109 | 2 | O-RING |
| 4 | O-U-011 | 2 | O-RING |
| 5 | O-D-010 | 1 | O-RING |
| 6 | 02647-3 | 2 | FLAT HEAD TORX SCREW |
| 7 | F-FS-540-08 | 1 | SLOTTED FILLISTER HEAD SCREW |
| 8 | 02970 | 1 | HAIRPIN COTTER |
| 10 | 58624-1 | 1 | PRO GUN HANDLE |
| 11 | 58625-1 | 1 | PRO GUN TRIGGER |
| 12 | 58628-1 | 1 | TRIGGER GUIDE BUSHING |
| 13 | 58629-1 | 1 | TRIGGER GUIDE PIN |
| 14 | 58647-1 | 1 | TRIGGER VALVE ASSY |
| 15 | 58648-1 | 1 | TRIGGER RETAINER |
| 16 | 04017 | 1 | SPRING |
| 21 | 03198 | 1 | 1/8" CHROME BALL |

Chopper Handle Assy - Pro Gun 58603-1

PARTS LIST

| ITEM | PART NO. | QTY | DESCRIPTION |
|------|-----------|-----|-----------------------|
| 9 | 05500 | 1 | PIPE THREAD SEAL |
| 20 | 7701-6-18 | 1 | MALE POLY ELBOW |
| 22 | 00003-1 | 1 | STRAIGHT POLY FITTING |

Gelcoat Handle Assy - Pro Gun 58603-3

PARTS LIST

| ITEM | PART NO. | QTY | DESCRIPTION |
|------|----------|-----|-----------------------|
| 18 | PF-AP-02 | 1 | PIPE PLUG |
| 22 | 00003-1 | 1 | STRAIGHT POLY FITTING |
| 23 | 5102-1-1 | 1 | STRAIGHT POLY FITTING |

OPTIONAL PARTS AND ASSEMBLIES

| ITEM | PART NO. | QTY | DESCRIPTION |
|------|-------------|-----|-----------------------------------|
| 12A | 58628-1-SS | 1 | TRIGGER GUIDE BUSHING (STAINLESS) |
| 13A | 58629-1-SS | 1 | TRIGGER GUIDE PIN (STAINLESS) |
| 19 | 58629-3 | 1 | TRIGGER GUIDE PIN (NON LOCKING) |
| | CPG-1007-CK | 1 | TRIGGER UPGRADE CONVERSION KIT |

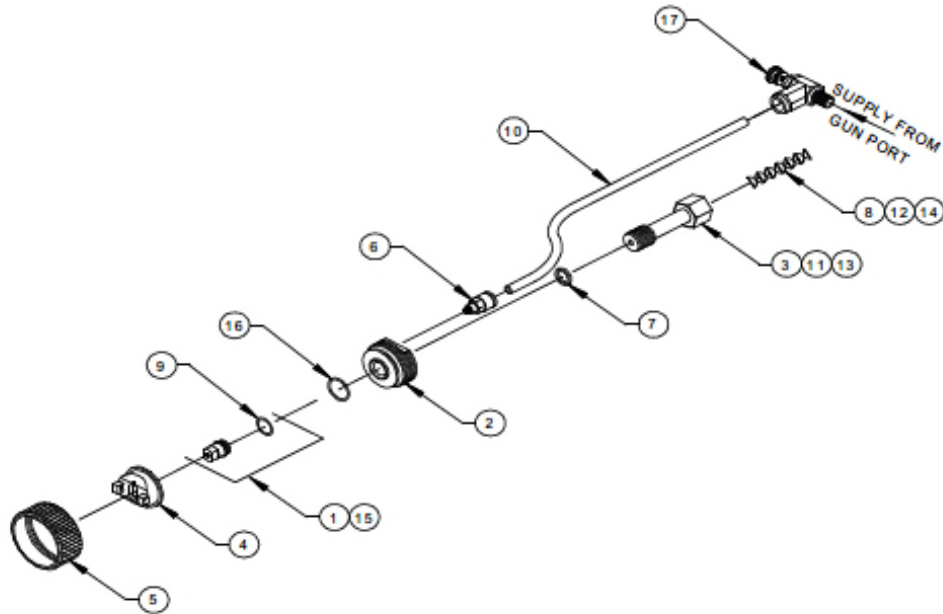

MAGNUM VENUS PRODUCTS

| | |
|--|------------------|
| Air Assist Assy - Short Mixer | VPA-1000 |
| Air Assist Assy - 1/4" dia. Long Mixer | VPA-1000-04L |
| Air Assist Assy - 3/8" dia. Long Mixer | VPA-1000-06L |
| Air Assist Assy (Robotic) - Short Mixer | VPA-1000-ROB |
| Air Assist Assy (Robotic) - 1/4" dia. Long Mixer | VPA-1000-04L-ROB |
| Air Assist Assy (Robotic) - 3/8" dia. Long Mixer | VPA-1000-06L-ROB |

REV. B - ITEM # 6 WAS VPA-1004 TUBE NIPPLE 9/29/03 JEM
 C - ITEM # 4 WAS VPA-1002 12/2/03 JEM
 D - ADDED ITEM 17 (7702-3-1 NEEDLE VALVE) 1/28/05 JEM

Common Assembly Parts For

- Air Assist Assy-Short Mixer VPA-1000
- Air Assist Assy - 1/4" Dia Long Mixer VPA-1000-04L
- Air Assist Assy - 3/8" Dia Long Mixer VPA-1000-06L
- Air Assist Assy (Robotic) - Short Mixer VPA-1000-ROB
- Air Assist Assy (Robotic) - 1/4" Dia Long Mixer VPA-1000-04L-ROB
- Air Assist Assy (Robotic) - 3/8" Dia Long Mixer VPA-1000-06L-ROB

PARTS LIST

| ITEM | PART NO. | QTY | DESCRIPTION |
|------|----------|-----|------------------|
| 2 | VPA-1001 | 1 | HOUSING |
| 4 | VPA-1007 | 1 | AIR CAP |
| 5 | VPA-1003 | 1 | AIR CAP RETAINER |
| 6 | 06977 | 1 | TUBE FITTING |
| 7 | 02030-1 | 1 | SEAL |
| 10 | 01449 | 1* | ORANGE POLY TUBE |
| 16 | O-S-018 | 1 | O-RING |
| 17 | 7702-3-1 | 1 | NEEDLE VALVE |

NOTE: THIS ASSEMBLY IS TO BE USED WITH A TURBULENT MIXER IN THE GUN HEAD. IF YOU ARE USING THIS ASSEMBLY W/O A TURBULENT MIXER YOU NEED TO ADD (1) 02030-1 SEAL, BETWEEN THE AIR ASSIST AND THE GUN HEAD.

★ TIPS ARE AVAILABLE IN VARIOUS SIZES FOR ROBOTIC APPLICATIONS ORDER ATG-XXX-ROB & ATC-XXX-ROB TIPS

Air Assist Assy-Short Mixer VPA-1000

PARTS LIST

| ITEM | PART NO. | QTY | DESCRIPTION |
|------|----------|-----|---------------------|
| 1 | ★ATG-518 | 1 | ASSY - SPRAY NOZZLE |
| 3 | 50093-1 | 1 | SHORT MIXER HOUSING |
| 8 | 05224 | 1 | MIXER ELEMENT |

Air Assist Assy - 1/4" Dia Long Mixer VPA-1000-04L

PARTS LIST

| ITEM | PART NO. | QTY | DESCRIPTION |
|------|----------|-----|-------------------------|
| 1 | ★ATG-518 | 1 | ASSY - SPRAY NOZZLE |
| 11 | 50091-1 | 1 | LONG 1/4" MIXER HOUSING |
| 12 | 8705-1-1 | 1 | 1/4" LONG MIXER |

Air Assist Assy - 3/8" Dia Long Mixer VPA-1000-06L

PARTS LIST

| ITEM | PART NO. | QTY | DESCRIPTION |
|------|----------|-----|---------------------|
| 1 | ★ATG-518 | 1 | ASSY - SPRAY NOZZLE |
| 13 | 50056-1 | 1 | 3/8" MIXER HOUSING |
| 14 | 05244 | 1 | 3/8" MIXER |

Air Assist Assy (Robotic) - Short Mixer VPA-1000-ROB

PARTS LIST

| ITEM | PART NO. | QTY | DESCRIPTION |
|------|--------------|-----|-------------------------------|
| 15 | ★ATG-518-ROB | 1 | ASSY - SPRAY NOZZLE (ROBOTIC) |
| 3 | 50093-1 | 1 | SHORT MIXER HOUSING |
| 8 | 05224 | 1 | MIXER ELEMENT |

Air Assist Assy (Robotic) - 1/4" Dia Long Mixer VPA-1000-04L-ROB

PARTS LIST

| ITEM | PART NO. | QTY | DESCRIPTION |
|------|--------------|-----|-------------------------------|
| 15 | ★ATG-518-ROB | 1 | ASSY - SPRAY NOZZLE (ROBOTIC) |
| 11 | 50091-1 | 1 | LONG 1/4" MIXER HOUSING |
| 12 | 8705-1-1 | 1 | 1/4" LONG MIXER |

Air Assist Assy (Robotic) - 3/8" Dia Long Mixer VPA-1000-06L-ROB

PARTS LIST

























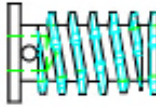

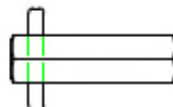



| ITEM | PART NO. | QTY | DESCRIPTION |
|------|--------------|-----|-------------------------------|
| 15 | ★ATG-518-ROB | 1 | ASSY - SPRAY NOZZLE (ROBOTIC) |
| 13 | 50056-1 | 1 | 3/8" MIXER HOUSING |
| 14 | 05244 | 1 | 3/8" MIXER |

Optional Parts And Assemblies























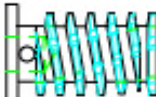

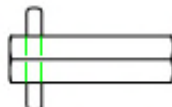





PARTS LIST

| ITEM | PART NO. | QTY | DESCRIPTION |
|------|----------|-----|-------------------------|
| 9 | O-E-012 | 1 | O RING |
| | 05486 | 1 | SWIVEL BODY (NOT SHOWN) |

CP3-1000-RK
MAJOR REPAIR KIT – PRO DUO GUN

| | | | | | |
|-------|---|---|-------|--|-------------------------------|
| 1 PC |  | O-S-008 O-RING | 2 PCS |  | 5104-3-1 SECONDARY SEAL |
| 1 PC |  | O-S-3-903 O-RING | 2 PC |  | 5104-26-1 FLUSH VALVE SEAL |
| 1 PC |  | O-S-018 O-RING | 2 PC |  | 5104-21-1 SPLIT SEAL |
| 2 PC |  | O-E-007 O-RING | 4 PCS |  | 5104-7-1 PACKING RING |
| 2 PC |  | O-E-008 O-RING *DO NOT GREASE THIS O-RING* | 1 PC |  | 5104-13-1 INJECTOR SEAL |
| 2 PC |  | O-E-3-904 O-RING | 2 PC |  | 5104-5-1 TEFLON RESIN SEAL |
| 1 PC |  | O-E-012 O-RING | 1 PC |  | 5104-6-1 TEFLON CATALYST SEAL |
| 1 PC |  | O-D-010 O-RING | 1 PC |  | 5107-27-2 TURBULENT MIXER |
| 2 PCS |  | O-U-011 O-RING | 1 PC |  | 6705-1-1 PACKING BIT |
| 2 PCS |  | O-U-109 O-RING | 2 PCS |  | 02441-1 SEAL |
| 2 PCS |  | O-V-013 O-RING | 2 PCS |  | 03199 BALL 1/4" |
| 3 PCS |  | O-V-020 O-RING | 2 PCS |  | 04319 STAINLESS SPRING |
| 2 PCS |  | 58694-1 FACE SEAL | 1 PC |  | 02030-1 SEAL |
| 2 PCS |  | 58695-1 PLUG SEAL | 4 PCS |  | 7304-3-1 NYLON SEAL |
| 4 PCS |  | 5106-3-1 GUN BLOCK SEAL | 1 PC |  | 05224 MIXER ELEMENT |
| 1 PC |  | CP3-1012 MIX HOUSING SEAL | | | |

CP3-2000-RK
MAJOR REPAIR KIT – PRO DUO GUN

| | | | | | |
|-------|---|---|-------|--|-------------------------------|
| 2 PCS |  | O-S-006 O-RING | 2 PCS |  | 5104-3-1 SECONDARY SEAL |
| 1 PC |  | O-S-3-903 O-RING | 2 PC |  | 5104-26-1 FLUSH VALVE SEAL |
| 1 PC |  | O-S-012 O-RING | 2 PC |  | 5104-21-1 SPLIT SEAL |
| 1 PC |  | O-S-014 O-RING | 4 PCS |  | 5104-7-1 PACKING RING |
| 2 PC |  | O-E-007 O-RING | 2 PC |  | 5104-5-1 TEFLON RESIN SEAL |
| 2 PC |  | O-E-008 O-RING *DO NOT GREASE THIS O-RING* | 1 PC |  | 5104-6-1 TEFLON CATALYST SEAL |
| 2 PC |  | O-E-3-904 O-RING | 1 PC |  | 5107-27-2 TURBULENT MIXER |
| 2 PCS |  | O-E-012 O-RING | 1 PC |  | 6705-1-1 PACKING BIT |
| 1 PC |  | O-D-010 O-RING | 2 PCS |  | 02441-1 SEAL |
| 2 PCS |  | O-U-011 O-RING | 2 PCS |  | 03199 BALL 1/4" |
| 2 PCS |  | O-U-109 O-RING | 2 PCS |  | 04319 STAINLESS SPRING |
| 2 PCS |  | O-V-013 O-RING | 1 PC |  | 02030-1 SEAL |
| 3 PCS |  | O-V-020 O-RING | 4 PCS |  | 7304-3-1 NYLON SEAL |
| 2 PCS |  | 58694-1 FACE SEAL | 1 PCS |  | 9201-1-7 BALL 7/32" |
| 2 PCS |  | 58695-1 PLUG SEAL | 1 PCS |  | 4101-16-1 SPRING |
| 4 PCS |  | 5106-3-1 GUN BLOCK SEAL | | | |



Magnum Industries Europe Ltd. t/a Magnum Venus Products

Official Distributor of MVP Range in the United Kingdom and Ireland

Unit 22a, Navigation Drive, Hurst Business Park,
Brierley Hill, West Midlands, DY5 1UT, UK.

phone: +44 (0)1384 486222
email: info@mvpeurope.co.uk
website: www.mvpeurope.co.uk