

5-Gallon Putty Unit

Operations Manual

This manual is applicable to the following models:

- IMP-PAT-CCP-MP-5

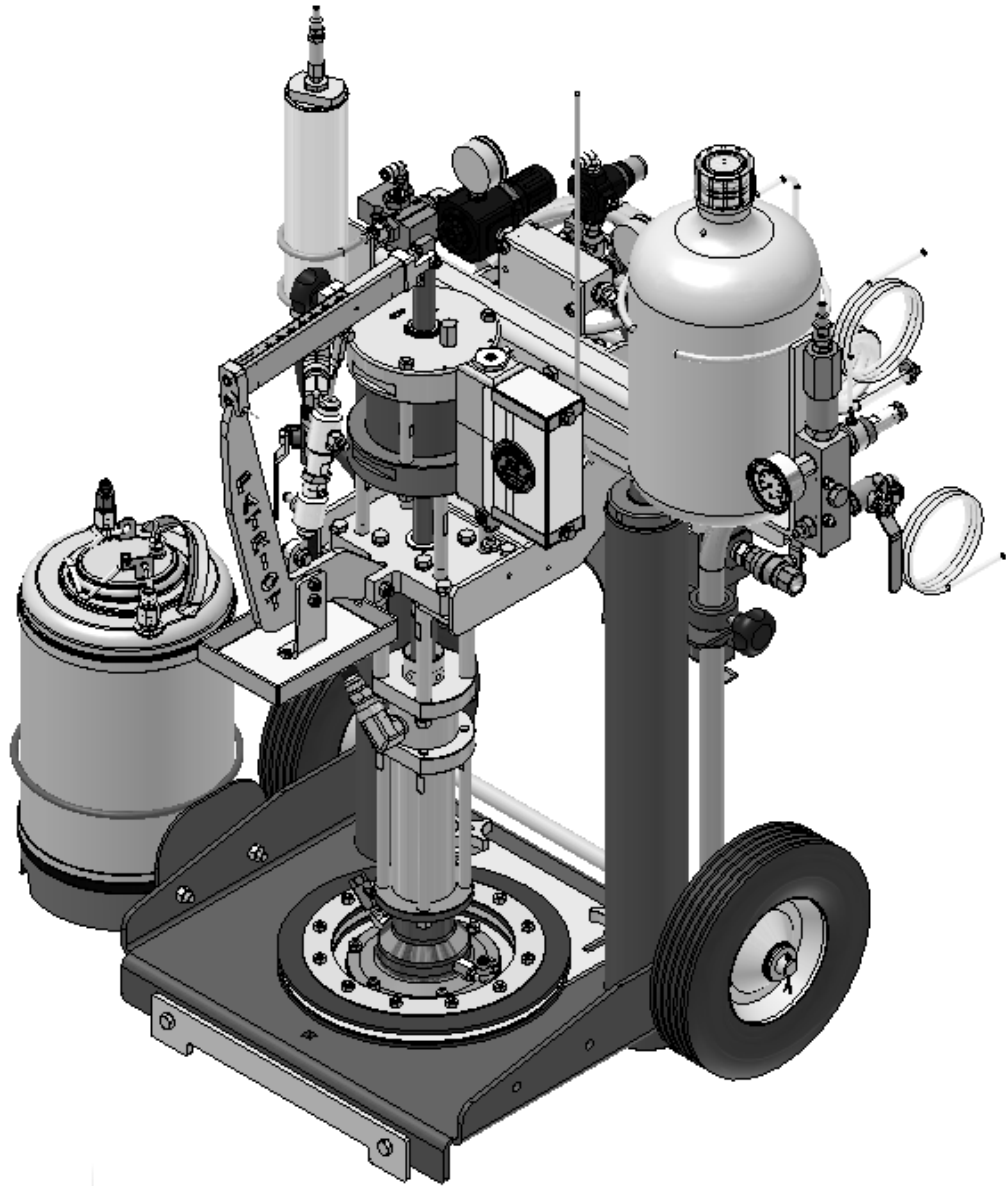

Rev. April 2020



Magnum Industries Europe Ltd. t/a Magnum Venus Products

Official Distributor of MVP Range in the United Kingdom and Ireland

Unit 22a, Navigation Drive, Hurst Business Park,
Brierley Hill, West Midlands, DY5 1UT, UK.

phone: +44 (0)1384 486222
email: info@mvpeurope.co.uk
website: www.mvpeurope.co.uk

Table of Contents

Section	Page
• Table of Contents	3
• Safety & Warning Information	4
• Introduction	15
• Assembling the Unit	19
• Getting Started	19
• Priming the Unit	20
• Mixing and Dispensing	22
• Testing and Adjusting	23
• Flushing and Shutting Down	25
• Changing an Empty Pail	26
• Performing Daily Tasks	27

Safety & Warning Information

Warnings

Due to the vast number of chemicals that could be used and their varying chemical reactions, the buyer and user of this equipment should determine all factors relating to the fluids used, including any of the potential hazards involved. Particular inquiry and investigation should be made into potential dangers relating to toxic fumes, fires, explosions, reaction times, and exposure of human beings to the individual components or their resultant mixtures. MVP assumes no responsibility for loss, damage, expense or claims for bodily injury or property damage, direct or consequential, arising from the use of such chemical components.

The end user is responsible for ensuring that the end product or system complies with all the relevant laws in the country where it is to be used and that all documentation is adhered to.

Recommended Occupational Safety & Health Act (OSHA) Documentation:

- 1910.94 Pertaining to ventilation
- 1910.106 Pertaining to flammable liquids
- 1910.107 Pertaining to spray finishing operations, particularly paragraph (m), Organic Peroxides and Dual Component Coatings

For Additional information, contact the Occupational Safety and Health Administration (OSHA) at <https://www.osha.gov/about.html>.

Recommended National Fire Protection Association (NFPA) Documentation:

- NFPA No.33 Chapter 14 Organic Peroxides and Dual Component Materials
- NFPA No. 63 Dust Explosion Prevention
- NFPA No. 70 National Electrical Code
- NFPA No. 77 Static Electricity
- NFPA No. 91 Blower and Exhaust System
- NFPA No. 654 Plastics Industry Dust Hazards

Fire Extinguisher – code ABC, rating number 4a60bc using Extinguishing Media –Foam, Carbon Dioxide, Dry Chemical, Water Fog, is recommended for this product and applications.

The following general warnings and guidelines are for the setup, use, grounding, maintenance, and repair of equipment. Additional product-specific warnings may be found throughout this manual as applicable. Please contact your nearest MVP Technical Service Representative if additional information is needed.

Safety Precautions

- Avoid skin contact and inhalation of all chemicals.
- Review Material Safety Data Sheet (MSDS) to promote the safe handling of chemicals in use.
- Restrict the use of all chemicals to designated areas with good ventilation.
- Chemicals are flammable and reactive.
- Noxious fumes released when combusted.
- Operate equipment in a ventilated environment only.
- Uncured liquid resins are highly flammable unless specifically labeled otherwise.
- Cured laminate, accumulations of overspray, and laminate sandings are highly combustible.
- Do not operate or move electrical equipment when flammable fumes are present.
- Ground all equipment.
- If a spark is seen or felt, immediately halt operation. Do not operate the equipment until the issue has been identified and repaired.
- Contaminated catalyst may cause fire or explosion.
- Containers may explode if exposed to fire / heat.
- Use and store chemicals away from heat, flames, and sparks.
- Do not smoke in work areas or near stored chemicals.
- Do not mix Methyl Ethyl Ketone Peroxide (MEKP) with materials other than polyethylene.
- Do not dilute MEKP.
- Keep food and drink away from work area.



Physical Hazards

- Never look directly into the spray gun fluid tip. Serious injury or death can result.
- Never aim the spray gun at or near another person. Serious injury or death can result.
- Chemical compounds can be severely irritating to the eyes and skin.
- Inhalation, ingestion, or injection may damage internal organs and lead to pulmonary disorders, cancers, lymphomas, and other diseases or health conditions.
- Other potential health effects include: irritation of the eyes and upper respiratory tract, headache, light-headedness, dizziness, confusion, drowsiness, nausea, vomiting, and occasionally abdominal pain.
- Eye contact: Immediately flush with water for at least 15 minutes and seek immediate medical attention.
- Skin Contact: Immediately wash with soap and water and seek immediate medical attention.
- Inhalation: Move the person to fresh air and seek immediate medical attention.
- Do not remove shields, covers, or safety features on equipment that is in use.
- Never place fingers, hands, or any body part near or directly in front of the spray gun fluid tip. The force of the liquid as it exits the spray tip can shoot liquid through the skin.
- Keep hands and body parts away from any moving equipment or components.
- Do not stand under plunger
- An improperly loaded pail may lead to an imbalance, causing a unit to tip over

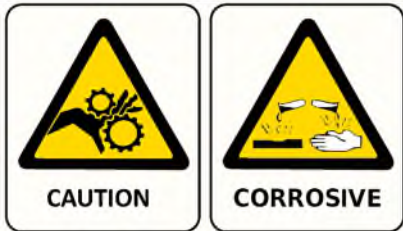

Personal Protective Equipment (PPE)

- MVP recommends the use of personal safety equipment with all products in our catalog.
- Wear safety goggles, hearing protection, a respirator, and chemical resistant gloves.
- Wear long sleeve shirts or jackets and pants to minimize skin exposure.
- PPE should be worn by operators and service technicians to reduce the risk of injury.



For Additional information, contact the Occupational Safety and Health Administration (OSHA). <https://www.osha.gov/about.html>

Symbol Definitions



Indicates the risk of contact with chemicals that are hazardous, which may lead to injury or death.



Indicates the risk of contact with voltage / amperage that may lead to serious injury or death



Indicates that the materials being used are susceptible to combustion



Indicates the risk of contact with moving components that may lead to serious injury or death.



Indicates that the system or component should be grounded before proceeding with use or repair.



Indicates the use of lit cigarettes or cigars is prohibited, because the materials being used are susceptible to combustion.



Indicates that the materials and/or the process being performed can lead to ignition and explosion.



A recommendation for the use of Personal Protective Equipment (PPE) before using or repairing the product.

Polymer Matrix Materials: Advanced Composites

Potential health hazards associated with the use of advanced composites can be controlled through the implementation of an effective industrial hygiene and safety program.

https://www.osha.gov/dts/osta/otm/otm_iii/otm_iii_1.html#t_iii:1_1

Resins		
Composite Component	Organ System Target (Possible Target)	Known (Possible) Health Effect
Epoxy resins	Skin, lungs, eyes	Contact and allergic dermatitis, conjunctivitis
Polyurethane resins	Lungs, skin, eyes	Respiratory sensitization, contact dermatitis, conjunctivitis
Phenol formaldehyde	Skin, lungs, eyes	As above (potential carcinogen)
Bismaleimides (BMI)	Skin, lungs, eyes	As above (potential carcinogen)
Polyamides	Skin, lungs, eyes	As above (potential carcinogen)
Reinforcing materials		
Composite Component	Organ System Target (Possible Target)	Known (Possible) Health Effect
Aramid fibers	Skin (lungs)	Skin and respiratory irritation, contact dermatitis (chronic interstitial lung disease)
Carbon/graphite fibers	Skin (lungs)	As noted for aramid fibers
Glass fibers (continuous filament)	Skin (lungs)	As noted for aramid fibers
Hardeners and curing agents		
Composite Component	Organ System Target (Possible Target)	Known (Possible) Health Effect
Diaminodiphenylsulfone	N/A	No known effects with workplace exposure
Methylenedianiline	Liver, skin	Hepatotoxicity, suspect human carcinogen
Other aromatic amines		
Composite Component	Organ System Target (Possible Target)	Known (Possible) Health Effect
Meta-phenylenediamine (MPDA)	Liver, skin (kidney, bladder)	Hepatitis, contact dermatitis (kidney and bladder cancer)
Aliphatic and cyclo-aliphatic amines	Eyes, skin	Severe irritation, contact dermatitis
Polyaminoamide	Eyes, skin	Irritation (sensitization)
Anhydride	Eyes, lungs, skin	Severe eye and skin irritation, respiratory sensitization, contact dermatitis

Catalyst - Methyl Ethyl Ketone Peroxide (MEKP)

MEKP is among the more hazardous materials found in commercial channels. The safe handling of the “unstable (reactive)” chemicals presents a definite challenge to the plastics industry. The highly reactive property which makes MEKP valuable to the plastics industry in producing the curing reaction of polyester resins also produces the hazards which require great care and caution in its storage, transportation, handling, processing and disposal. MEKP is a single chemical. Various polymeric forms may exist which are more or less hazardous with respect to each other. These differences may arise not only from different molecular structures (all are, nevertheless, called “MEKP”) and from possible trace impurities left from the manufacture of the chemicals, but may also arise by contamination of MEKP with other materials in its storage or use. Even a small amount of contamination with acetone, for instance, may produce an extremely shock-sensitive and explosive compound.



WARNING

Contamination with promoters, materials containing promoters (such as laminate sandings), or with any readily oxidizing material (such as brass or iron) will cause exothermic redox reactions which can be explosive in nature. Heat applied to MEKP or heat buildup from contamination reactions can cause the material to reach its Self-Accelerating Decomposition Temperature (SADT).

Researchers have reported measuring pressure rates-of-rise well over 100,000 psi per second when certain MEKP's reach their SADT. For comparison, the highest-pressure rate-of-rise listed in NFPA Bulletin NO.68, “Explosion Venting”, is 12,000 psi per second for an explosion of 12% acetylene and air. The maximum value listed for a hydrogen explosion is 10,000 psi per second. Some forms of MEKP, if allowed to reach their SADT, will burst even an open topped container. This suggests that it is not possible to design a relief valve to vent this order of magnitude of pressure rate-of-rise. The user should be aware that any closed container, be it a pressure vessel, surge chamber, or pressure accumulator, could explode under certain conditions. There is no engineering substitute for care by the user in handling organic peroxide catalysts. If, at any time, the pressure relieve valve on top of the catalyst tank should vent, the area should be evacuated at once and the fire department called. The venting could be the first indication of a heat, and therefore, pressure build-up that could eventually lead to an explosion. Moreover, if a catalyst tank is sufficiently full when the pressure relief valve vents, some catalyst may spray out, which could cause eye injury. For this reason, and many others, anyone whose job puts them in an area where this vented spray might go, should always wear full eye protection even when laminating operations are not taking place.

Safety in handling MEKP depends to a great extent on employee education, proper safety instructions, and safe use of the chemicals and equipment. Workers should be thoroughly informed of the hazards that may result from improper handling of MEKP, especially regarding contamination, heat, friction and impact. They should be thoroughly instructed regarding the proper action to be taken in the storage, use, and disposal of MEKP and other hazardous materials used in the laminating operation. In addition, users should make every effort to:

- Store MEKP in a cool, dry place in original containers away from direct sunlight and away from other chemicals.
- Keep MEKP away from heat, sparks, and open flames.
- Prevent contamination or MEKP with other materials, including polyester over spray and sandings, polymerization accelerators and promoters, brass, aluminum, and non-stainless steels.

- Never add MEKP to anything that is hot, since explosive decomposition may result.
- Avoid contact with skin, eyes, and clothing. Protective equipment should be worn at all times. During clean-up of spilled MEKP, personal safety equipment, gloves, and eye protection must be worn. Firefighting equipment should be at hand and ready.
- Avoid spillage, which can heat up to the point of self-ignition.
- Repair any leaks discovered in the catalyst system immediately, and clean-up the leaked catalyst at once in accordance with the catalyst manufacturer's instructions.
- Use only original equipment or equivalent parts from Magnum Venus Products in the catalyst system (i.e.: hoses, fitting, etc.) because a dangerous chemical reaction may result between substituted parts and MEKP.
- Catalyst accumulated from the purging of hoses or the measurement of fluid output deliveries should never be returned to the supply tank, such catalyst should be diluted with copious quantities of clean water and disposed of in accordance with the catalyst manufacturer's instructions.

The extent to which the user is successful in accomplishing these ends and any additional recommendations by the catalyst manufacturer determines largely the safety that will be present in his operation.

Clean-Up Solvents and Resin Diluents



WARNING

A hazardous situation may be present in your pressurized fluid system! Hydro carbon solvents can cause an explosion when used with aluminum or galvanized components in a closed (pressurized) fluid system (pump, heaters, filters, valves, spray guns, tanks, etc.). An explosion could cause serious injury, death, and/or substantial property damage. Cleaning agents, coatings, paints, etc. may contain Halogenated Hydrocarbon solvents. Some Magnum Venus Products spray equipment includes aluminum or galvanized components and will be affected by Halogenated Hydrocarbon solvents.

There are three key elements to the Halogenated Hydrocarbon (HHC) solvent hazard.

- | | | |
|----|---|--|
| 1. | The presence of HHC solvents. | 1,1,1 – Trichloroethane and Methylene Chloride are the most common of these solvents. However, other HHC solvents are suspect if used; either as part of paint or adhesives formulation, or for clean-up flushing. |
| 2. | Aluminum or Galvanized Parts. | Most handling equipment contains these elements. In contact with these metals, HHC solvents could generate a corrosive reaction of a catalytic nature. |
| 3. | Equipment capable of withstanding pressure. | When HHC solvent contact aluminum or galvanized parts inside a closed container such as a pump, spray gun, or fluid handling system, the chemical reaction can, over time, result in a build-up of heat and pressure, which can reach explosive proportions. When all three elements are present, the result can be an extremely violent explosion. The reaction can be sustained with very little aluminum or galvanized metal; any amount of aluminum is too much. |

- The reaction is unpredictable. Prior use of an HHC solvent without incident (corrosion or explosion) does NOT mean that such use is safe. These solvents can be dangerous alone (as a clean-up or flushing agent) or when used as a component or a coating material. There is no known inhibitor that is effective under all circumstances. Mixing HHC solvents with other materials or solvents such as MEKP, alcohol, or toluene may render the inhibitors ineffective.
- The use of reclaimed solvents is particularly hazardous. Reclaimers may not add any inhibitors. The possible presence of water in reclaimed solvents could also feed the reaction.
- Anodized or other oxide coatings cannot be relied upon to prevent the explosive reaction. Such coatings can be worn, cracked, scratched, or too thin to prevent contact. There is no known way to make oxide coatings or to employ aluminum alloys to safely prevent the chemical reaction under all circumstances.
- Several solvent suppliers have recently begun promoting HHC solvents for use in coating systems. The increasing use of HHC solvents is increasing the risk. Because of their exemption from many state implementation plans as Volatile Organic Compounds (VOCs), their low flammability hazard, and their not being classified as toxic or carcinogenic substances, HHC solvents are very desirable in many respects.



WARNING

Do not use Halogenated Hydrocarbon (HHC) solvents in pressurized fluid systems having aluminum or galvanized wetted parts.

Magnum Venus Products is aware of NO stabilizers available to prevent HHC solvents from reaction under all conditions with aluminum components in closed fluid systems. HHC solvents are dangerous when used with aluminum components in a closed fluid system.

- Consult your material supplier to determine whether your solvent or coating contains Halogenated Hydrocarbon solvents.
- Magnum Venus Products recommends that you contact your solvent supplier regarding the best non-flammable clean-up solvent with the heat toxicity for your application.
- If, however, you find it necessary to use flammable solvents, they must be kept in approved, electrically grounded containers.
- Bulk solvent should be stored in a well-ventilated, separate building, 50 feet away from your main plant.
- You should only allow enough solvent for one day's use in your laminating area.
- NO SMOKING signs must be posted and observed in all areas of storage or where solvents and other flammable materials are used.
- Adequate ventilation (as covered in OSHA Section 1910.94 and NFPA No.91) is important wherever solvents are stored or used, to minimize, confine and exhaust the solvent vapors.
- Solvents should be handled in accordance with OSHA Section 1910.106 and 1910.107.

Catalyst Diluents

Magnum Venus Products spray-up and gel-coat systems currently produced are designed so that catalyst diluents are not required. Magnum Venus Products therefore recommends that diluents not be used to avoid possible contamination which could lead to an explosion due to the handling and mixing of MEKP and diluents. In addition, it eliminates any problems from the diluent being contaminated through rust particles in pails, poor quality control on the part of the diluents suppliers, or any other reason. If diluents are absolutely required, contact your catalyst supplier

and follow his instructions explicitly. Preferably the supplier should premix the catalyst to prevent possible “on the job” contamination while mixing.



WARNING

If diluents are not used, remember that catalyst spillage and gun, hose, and packing leaks are potentially more hazardous since each drop contains a higher concentration of catalyst and will therefore react more quickly with overspray and the leak.

Cured Laminate, Overspray and Laminate Sandings Accumulation

- Remove all accumulations of overspray, Fiberglass Reinforced Plastic (FRP) sandings, etc. from the building as they occur. If this waste is allowed to build up, spillage of catalyst is more likely to start a fire; in addition, the fire would burn hotter and longer.
- Floor coverings, if used, should be non-combustible.
- Spilled or leaked catalyst may cause a fire if it comes in contact with an FRP product, oversprayed chop or resin, FRP sandings or any other material with MEKP.

To prevent spillage and leakage, you should:

- | | |
|--|---|
| 1. Maintain your Magnum Venus Products System. | Check the gun several times daily for catalyst and resin packing or valve leaks. REPAIR ALL LEAKS IMMEDIATELY. |
| 2. Never leave the gun hanging over or lying inside the mold. | A catalyst leak in this situation would certainly damage the part, possibly the mold, and may cause a fire. |
| 3. Inspect resin and catalyst hoses daily for wear or stress at the entry and exits of the boom sections and at the hose and fittings. | Replace if wear or weakness is evident or suspected. |
| 4. Arrange the hoses and fiberglass roving guides so that the fiberglass strands DO NOT rub against any of the hoses at any point. | If allowed to rub, the hose will be cut through, causing a hazardous leakage of material which could increase the danger of fire. Also, the material may spew onto personnel in the area. |

Toxicity of Chemicals

- Magnum Venus Products recommends that you consult OSHA Sections 1910.94, 1910.106, 1910.107 and NFPA No.33, Chapter 14, and NFPA No.91.
- Contact your chemical supplier(s) and determine the toxicity of the various chemicals used as well as the best methods to prevent injury, irritation and danger to personnel.
- Also determine the best methods of first aid treatment for each chemical used in your plant.

Equipment Safety

Magnum Venus Products suggest that personal safety equipment such as EYE GOGGLES, GLOVES, EAR PROTECTION, and RESPIRATORS be worn when servicing or operating this equipment. Ear protection should be worn when operating a fiberglass chopper to protect against hearing loss since noise levels can be as high as 116 dB (decibels). This equipment should only be operated or serviced by technically trained personnel!

**CAUTION**

Never place fingers, hands, or any body part near or directly in front of the spray gun fluid tip. The force of the liquid as it exits the spray tip can cause serious injury by shooting liquid through the skin. NEVER LOOK DIRECTLY INTO THE GUN SPRAY TIP OR POINT THE GUN AT OR NEAR ANOTHER PERSON OR AN ANIMAL.

**DANGER**

Contaminated catalyst may cause fire or explosion. Before working on the catalyst pump or catalyst accumulator, wash hands and tools thoroughly. Be sure work area is free from dirt, grease, or resin. Clean catalyst system components with clean water daily.

**DANGER**

Eye, skin, and respiration hazard. The catalyst MEKP may cause blindness, skin irritation, or breathing difficulty. Keep hands away from face. Keep food and drink away from work area.

Treatment of Chemical Injuries

**CAUTION**

Refer to your catalyst manufacturer's safety information regarding the safe handling and storage of catalyst. Wear appropriate safety equipment as recommended.

Great care should be used in handling the chemicals (resins, catalyst and solvents) used in polyester systems. Such chemicals should be treated as if they hurt your skin and eyes and as if they are poison to your body. For this reason, Magnum Venus Products recommends the use of protective clothing and eye wear in using polyester systems. However, users should be prepared in the event of such an injury.

Precautions include:

1. Know precisely what chemicals you are using and obtain information from your chemical supplier on what to do in the event the chemical gets onto your skin or into the eyes, or if swallowed.
2. Keep this information together and easily available so that it may be used by those administering first aid or treating the injured person.
3. Be sure the information from your chemical supplier includes instructions on how to treat any toxic effects the chemicals have.

**WARNING**

Contact your doctor immediately in the event of an injury. If the product's MSDS includes first aid instructions, administer first aid immediately after contacting a doctor.

Fast treatment of the outer skin and eyes that contact chemicals generally includes immediate and thorough washing of the exposed skin and immediate and continuous flushing of the eyes with lots of clean water for at least 15 minutes or more. These general instructions of first aid treatment may be incorrect for some chemicals; you must know the chemicals and treatment before an accident occurs. Treatment for swallowing a chemical frequently depends upon the nature of the chemical.

Emergency Stop Procedure

In an emergency, follow these steps to stop a system:

1. The ball valve located where the air enters the power head of the resin pump, should be moved to the “OFF” or closed position.

Note ***The “open” or “on” position is when the ball valve handle is parallel (in line) with the ball valve body. The “closed” or “off” position is when the ball valve handle is perpendicular (across) the ball valve body.***

2. Turn all system regulators to the “OFF” position (counter-clockwise) position.
3. Verify / secure the catalyst relief line, located on the catalyst relief valve.
4. Verify / secure the resin return line, located on the resin filter.
5. Place a container under the resin pump ball valve to catch ejected resin.
6. Locate the ball valve on the resin pump.
7. Rotate the ball valve 90 degrees to the “On” or open position.

Grounding

Grounding an object means providing an adequate path for the flow of the electrical charge from the object to the ground. An adequate path is one that permits charge to flow from the object fast enough that it will not accumulate to the extent that a spark can be formed. It is not possible to define exactly what will be an adequate path under all conditions since it depends on many variables. In any event, the grounding means should have the lowest possible electrical resistance.

Grounding straps should be installed on all loose conductive objects in the spraying area. This includes material containers and equipment. Magnum Venus Products recommends grounding straps be made of AWG No.18 stranded wire as a minimum and the larger wire be used where possible. NFPA Bulletin No77 states that the electrical resistance of such a leakage path should be 1 meg ohm (10^6 ohms) or less.



CAUTION

Whenever flammable or combustible liquids are transferred from one container to another, or from one container to the equipment, both containers or container and equipment shall be effectively bonded and grounded to dissipate static electricity. For further information, see National Fire Protection Association (NFPA) 77, titled “Recommended Practice on Static Electrical”. Refer especially to section 7-7 titled “Spray Application of Flammable and Combustible Materials”.

Introduction

This manual provides information for the operation, maintenance, and simple repair of the MVP Putty Unit. The following procedures are included:

- Step-by-step assembly and disassembly
- Installation, start-up, and shut-down instructions
- Step-by-step operation instructions



Please read this manual carefully and retain for future reference. Follow the steps in the order given, otherwise you may damage the equipment or injure yourself.

Component Assemblies

MVP's Putty Unit consists of multiple components. Each component has its own detailed manual and drawings. For complete repair and maintenance instructions, refer to the appropriate manuals.

- CLASSIC PRO GUN REPAIR MANUAL – SPRAY UNIT
- POWERHEAD MANUAL
- CHOP CHECK FLUID SECTION MANUAL
- METERING PUMP MANUAL

Air Requirements

1. The system requires a supply of air (30 cfm) and at least 100 psi (7 bar).
2. The unit requires a ½ inch (12 - 13 mm) inside diameter air hose minimum (use caution when using quick disconnects; they may restrict air flow).
3. Preferably the air will be clean, dry, and oil free.

Unit Overview

Below helps identify the main components and controls the operator needs to know for proper operation for the unit.

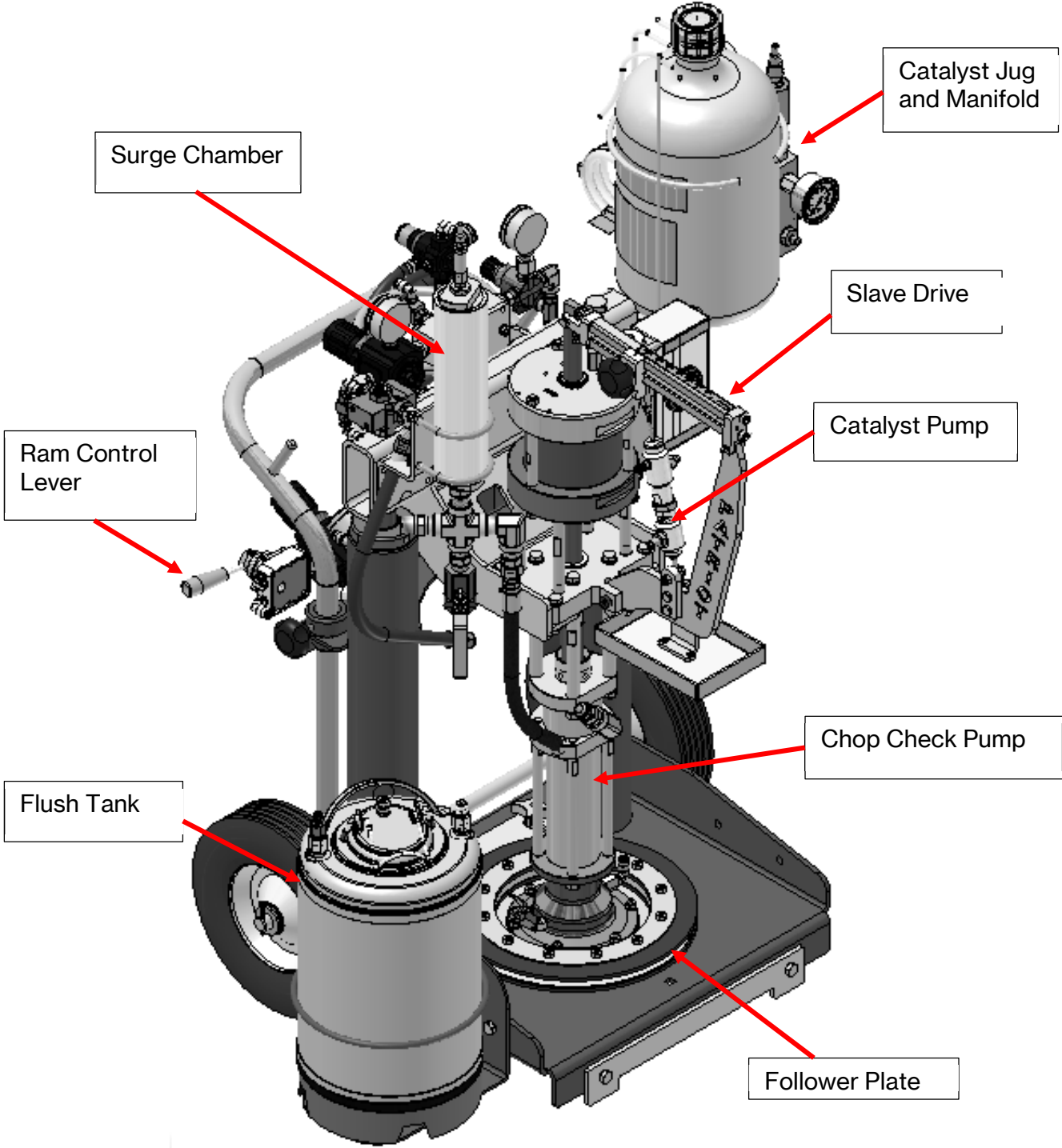

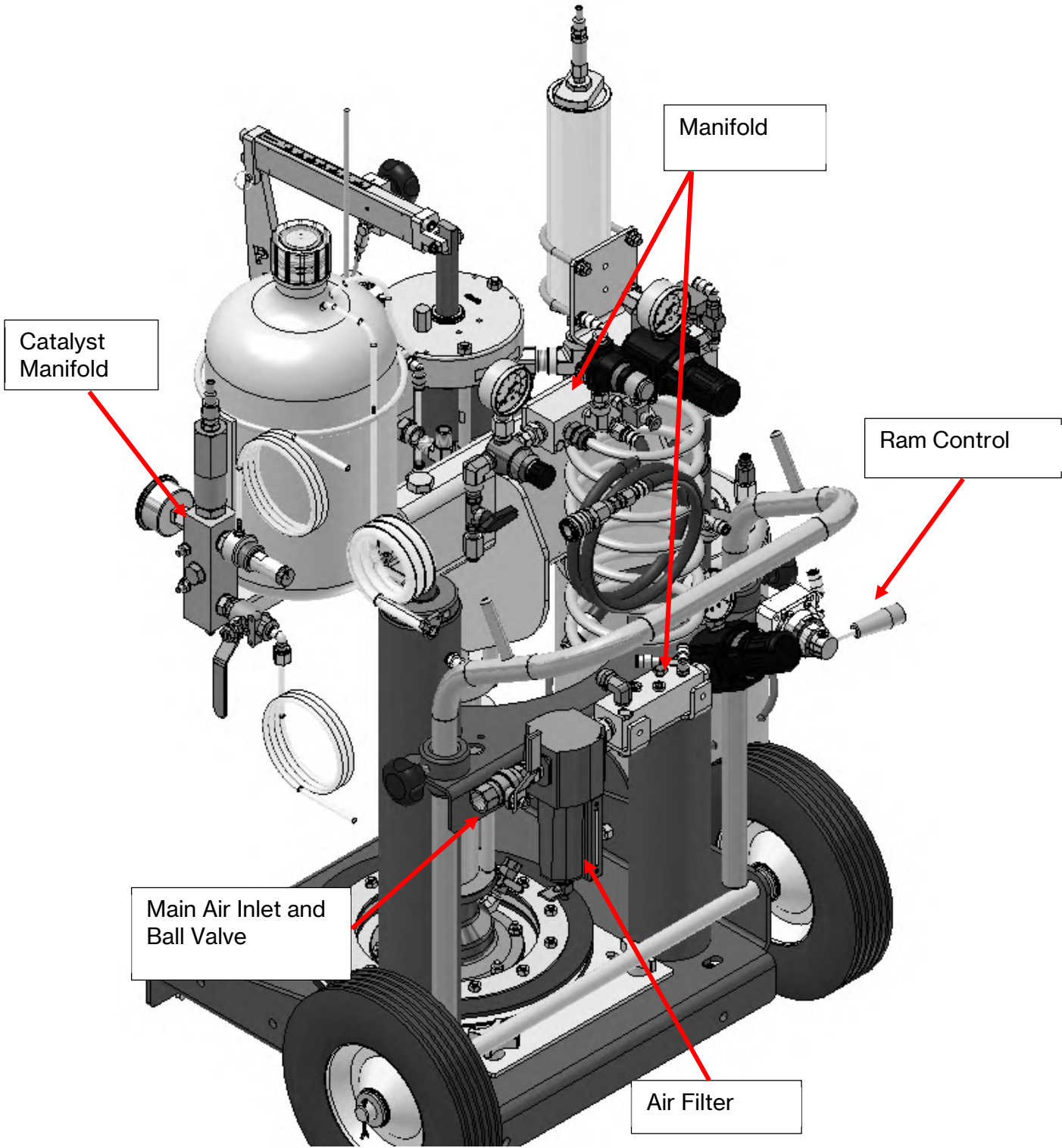

Overview of Controls

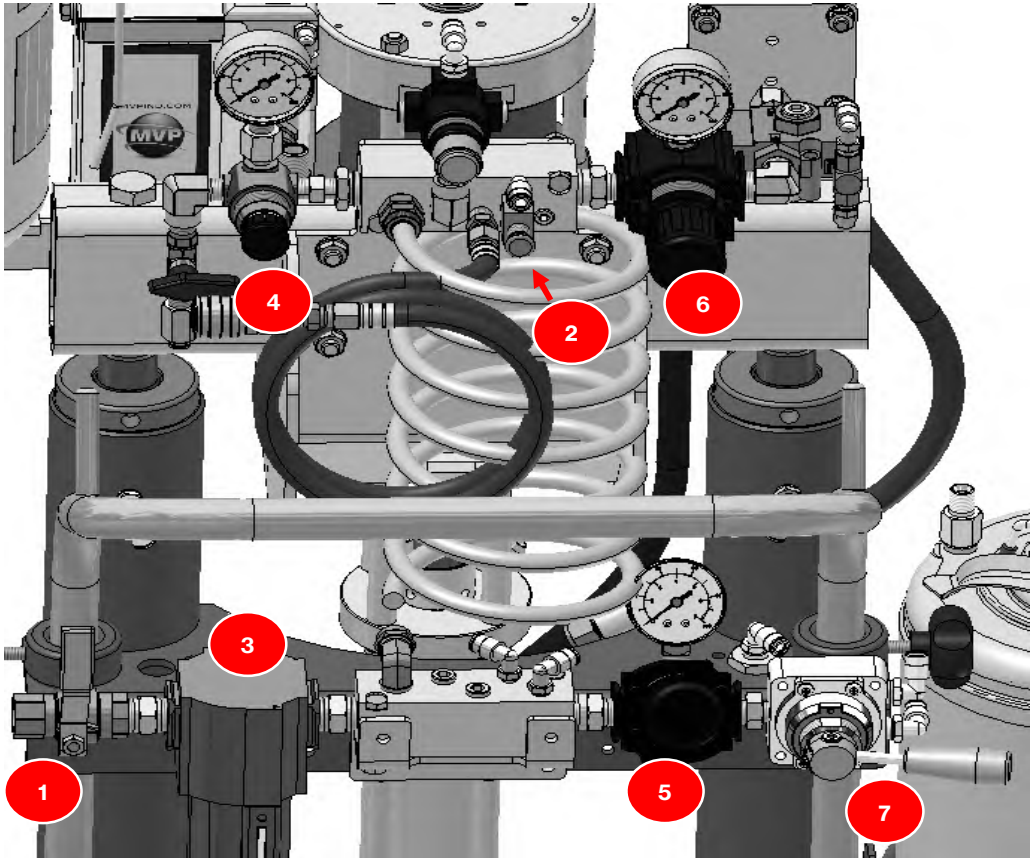

Main Air Manifold Controls		
No.	Description	Function
1	Main Air Inlet Valve	Used to turn air supply to the unit on or off and release pressure to the unit
2	Priming Button	Allows the pump to operate without opening the gun by sending an air signal to the pump control valve
3	Air Filter / Water Trap	Release valve for drain
4	Ram Extraction Pressure Gauge, Regulator, & Ball Valve	Used to apply air pressure between the ram piston and putty material to force the ram piston up and out of the pail
5	Air Lift Pressure Gauge, Regulator, & Ball Valve	Moves the ram piston and pump up or down, depending on which way the ram direction valve is set
6	Pump Pressure Gauge, Regulator, & Ball Valve	Controls the main air pressure to the resin pump air motor
7	Ram Direction Valve	Controls the direction (up or down) of the ram piston and pump

Assembling the Unit

1. Swing up and attach the catalyst manifold and bracket to the support bar.
2. Install the catalyst jug into the catalyst jug bracket.
3. Attach the flush tank bracket to the main post and install the flush tank.

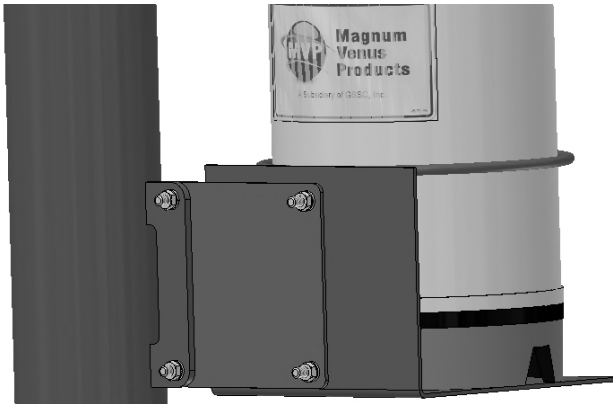

Figure 2. Flush Tank Attachment

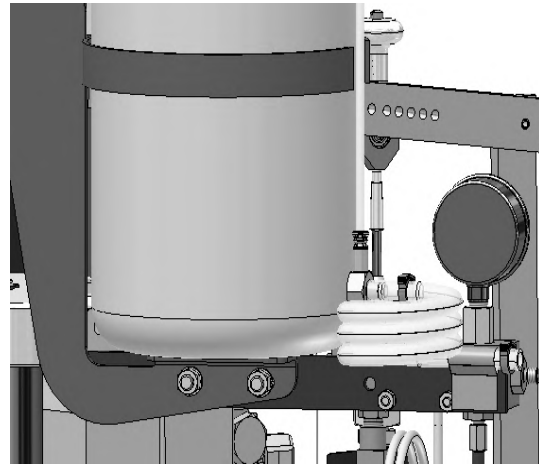

Figure 1. Catalyst Jug Bracket & Manifold

4. Loosen the two locking knobs and adjust the hose bracket to the desired position.
5. Loosen the U-bolts holding the accumulator in place and raise the accumulator to the proper position.

Connect Hoses

6. Connect the resin hose from the pump outlet to the accumulator.
7. Attach the flush tube (solvent to gun) to the outlet side of the flush tank.
8. Attach ¼ inch air hose from the regulator on the main air manifold to the flush tank regulator.
9. Connect the blue catalyst hose from the gun to the bottom of the catalyst manifold.
10. Connect the catalyst hose from the catalyst pump to the side of the catalyst manifold.
11. Install the relief valve and return valve tubes into the top of the catalyst jug.
12. Install the tube from the catalyst seal to the top of the catalyst jug.
13. Connect the catalyst feed tube from the catalyst jug outlet to the catalyst pump inlet.
14. Install the proper fitting into the main air supply ball valve and connect the air supply.

Note **The ball valve comes with a ½ inch NPT female port.**

Getting Started

1. Check all hoses for wear or damage; replace as necessary.
2. Check to make sure you have appropriate quantities of material to complete the job.
3. Check and repair or replace any damaged items before beginning operations.

4. Be sure all fluid connections are tight, including all catalyst fittings, resin fittings, and solvent fittings.

Priming the Unit

Prime Air and Solvent

1. Close the main air inlet valves on the main air manifolds.
2. Connect ½ inch main air supply to the air manifold.
3. Turn all regulators counterclockwise to full off and close all ball valves on the pump supply.
4. Make sure ram control lever is in the center (neutral) position.
5. Open the recirculation valve on the catalyst manifold to the ON position.
6. Open the main air supply ball valve and listen for air leaks.

Note ***The ball valve has a safety relief port and air will leak from the port unless the valve is fully open or closed.***

7. Secure all fittings and correct any leaks if found.
8. Fill the flush tank at least ¾ full with appropriate cleaning agent.
9. Close the relief valve on top of the flush tank.
10. Open the ball valve and slowly turn up regulator pressure to the flush tank or solvent pump.

Note ***If pump is used, turn up the regulator until the pump begins stroking.***

11. Secure any solvent leaks, if found.
12. Test the flush system by pressing the flush buttons on the gun block for both solvent and air purge if applicable.

Prime Putty Pump

13. Fill packing nut solvent cup with throat seal liquid (TSL).
14. Open the ball valve off the air lift cylinder regulator.
15. Turn the ram direction control lever to the up position.
16. Slowly turn up the air lift ram pressure regulator to between 10 and 20 psi (0.7 to 1.4 bar).
17. As ram begins to lift, check for hoses kinking or catching and correct as necessary.
18. Allow ram to go up to the fully raised position to allow clearance for the material container.
19. Stop the ram in the fully raised position and tape the round piece of plastic known as the piston boot to the barrel piston, making sure the hole in the center is centered with the opening at the bottom of the barrel piston.

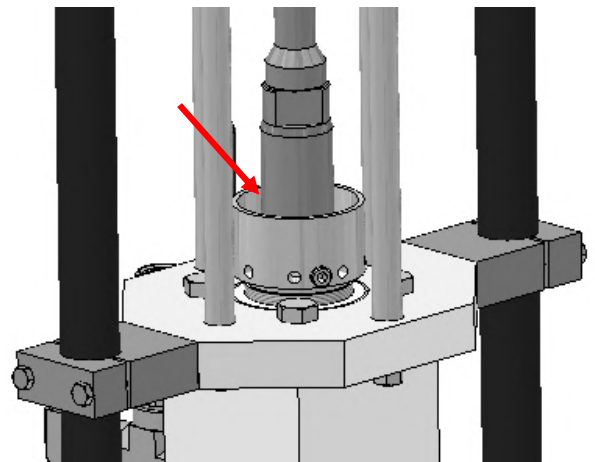

Note ***If the container of material you are using has a plastic liner, use the ring from the container top to hold the liner in place or tape the liner to the outside of the container to prevent it from being pushed down into the pail.***

20. Inspect the material container for dents or damage.

Note ***Using a dented or damaged container can damage the piston seals and cause leaking.***

21. Slide the material container onto the unit and center to the barrel piston.

22. Double check to make sure the opening of the plastic piston boot is lined up with the intake of the pump.

23. Open the air bleed ball valve located at the top of the barrel piston to allow air trapped between the piston and putty to escape.

24. Turn the direction control handle to the down position to lower the piston into the container.

25. Once piston has started into the container, slowly increase the air lift regulator pressure to between 40 and 60 psi (2.7 and 4 bar).

26. Allow time for air to be pushed out of the ball valve at the top of the barrel piston.

27. Once the piston has come to a complete stop and a small amount of material starts to come out of the ball valve, close the valve.

28. Remove the mixer assembly or nozzle from the front of the gun mix chamber if already installed.

29. Position the gun over an appropriate waste container.

30. Pull the gun trigger and lock in the ON position.

31. At the air manifold, slowly increase the pump pressure regulator.

32. Adjust pump regulator as needed to maintain a slow and uniform movement of the putty pump.

33. Allow the pump to run until a steady flow of material is being dispensed out of the gun with no air pockets.

34. Close the gun.

35. Position the outlet of the gun over an appropriate flush container.

36. Press the air purge button.

Note ***A sudden purge of material from the gun is likely and could splash. Use caution.***

37. Allow air to flow for 3-4 seconds.

38. Press the flush button to solvent purge for 3-4 seconds.

39. Repeat the flush several times as needed.

Prime Catalyst

Note ***Do not use the quick pin to attach the upper catalyst pump bearing block to the slave arm at this time.***

40. Check to make sure all catalyst hoses and fittings are tight.
41. Remove the mix chamber from the front of the gun.
42. Fill the catalyst jug $\frac{3}{4}$ full with appropriate catalyst.
43. Place the catalyst recirculation valve in the ON position.
44. Remove the quick pin from the slave drive.
45. Use the upper slave drive to slowly hand prime using long up and down strokes until a steady flow of catalyst is being returned to the jug.

Note ***When hand-priming catalyst pump, resistance should increase uniformly between the up stroke and the down stroke when building pressure.***

46. Secure leaks, if any.
47. Position outlet of gun over a flush container and lock the gun in the ON position.
48. Close the catalyst recirculation valve on the catalyst manifold.
49. Again hand pump catalyst using the slave arm until there is a steady flow of air-free catalyst coming from the front of the gun.
50. Release the gun trigger.
51. Flush and air purge as necessary.

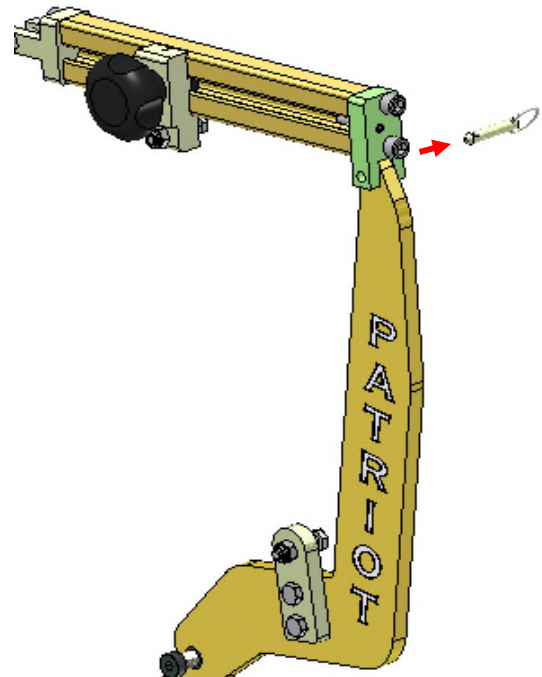

CAUTION

A sudden purge of material from the dispensing head is likely and could splash.

Mixing and Dispensing

1. Apply lubricant to the threads of the static mixer assembly and attach it to the outlet on the gun.
2. Trim the end of the disposable mixer to the desired diameter.
3. Push the priming button on the air manifold and slowly increase the putty pump regulator to the desired pressure.
4. Once pump comes to a stop, release the priming button.

5. With the gun closed and the catalyst pressure dump valve closed, hand prime catalyst pressure to at least 200 psi (14 bar).
6. Slide the catalyst pump to the desired percentage.
7. Reinsert the quick pin.
8. Open the gun and allow mixed material to flow out of mixer into a container for 4 – 5 seconds.
9. Begin dispensing a bead of material and check for mix by reviewing uniformity of color.

Testing and Adjusting

Output and Cure Time Test

1. Weigh and zero out a container on an appropriately sized scale.
2. Open the gun and allow material to flow for a second or two, then quickly move over the container.
3. Start timing for 1 minute, then close the gun.
4. Weigh the dispensed material to determine the weight per minute.
5. Observe the material until it begins to gel and note the elapsed time.

Mix Meter / Pour Test

6. Lay out a test strip of material such as cardboard, fabric, or plastic.
7. Pull the gun trigger and begin pouring a bead of material along the test strip in a zig-zag pattern, reversing direction when you hear the pump change direction.
8. Mark the spots on the pattern to indicate whether the pump was at the top or bottom of the stroke during the pour.

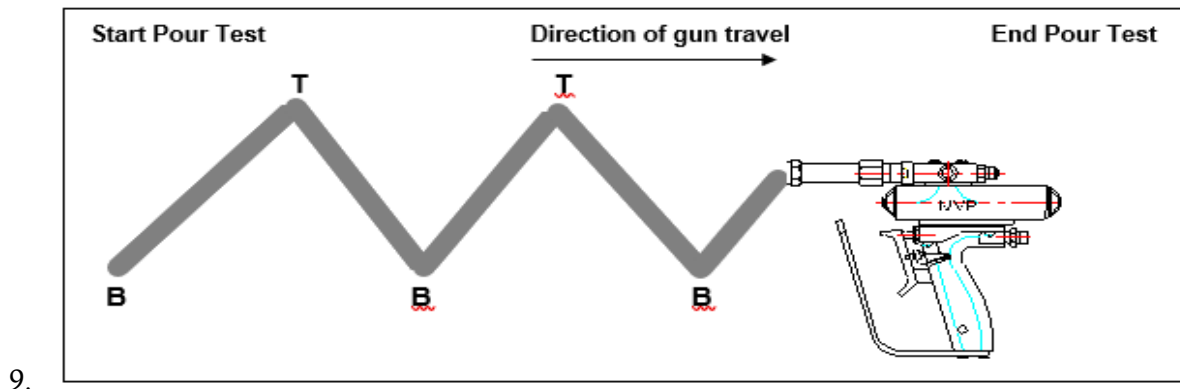

Evaluate and Troubleshoot

Note *Depending on the length of the mixer there may be a delay in the metering issue and where it appears in the pattern.*

10. If the bead of material is uniform in color and curing correctly, proceed with dispensing material as needed for your job and skip to shut down instructions.
11. If the pour test material does not appear to be curing uniformly, follow the guidelines in the following table to correct the issue:

Pour Test Adjustments			
If you see:	Indicates	Possible Cause	Solution
Material delivered on the activator pump down stroke is not curing or is slow cure. See below.	No or low activator is being delivered on the down stroke.	Worn or damaged intake valve.	Replace worn and damaged parts.
		Worn or damaged lower seat.	Replace worn and damaged parts.
		Dirty or stuck intake valve.	Clean or replace parts as needed.
Example:			
Material delivered on the activator pump up stroke is not curing or is slow cure. See below.	No or low activator is being delivered on the up stroke.	Worn or damaged piston seal.	Replace worn or damaged parts.
		Worn or damaged piston body ball.	Replace worn or damaged parts.
		Damaged piston body ball seat.	Replace worn or damaged parts.
Example:			
Material delivered at the top and bottom of the stroke is not curing or curing slower than the material delivered in the middle of the up and down stroke. See below.	Low or no activator at the top and bottom of the pump stroke.	There is no or improper accumulation effect in the activator system. Normally this is only a problem at high pressures.	Check to be sure you are using the proper activator hose and it is the proper length. Check for a restriction in the activator system.

Material delivered at the top and bottom of the stroke is hot (curing very rapidly). Thin areas of material may be noticeable compared to volume in the middle of the stroke. See below.	Low resin at the top and bottom of the pump stroke.	There is no or improper accumulator effect in the adhesive system.	Check to be sure you are using the proper adhesive hose and it is the proper length. Check for a restriction in the adhesive system.
Material delivered at the beginning of the down stroke is not curing normally. Also thin areas of material may be noticeable compared to the volume in the middle of the stroke. See below.	Low material delivery at the beginning of the pump stroke. Which pump depends on if it is curing slower or faster. Slow cure indicates less activator; fast cure means less adhesive.	The pump fluid section is not being filled correctly.	Increase ram/air lift pressure slightly until the issue goes away. Check that priming piston, priming seal, and relief washer are functioning correctly.

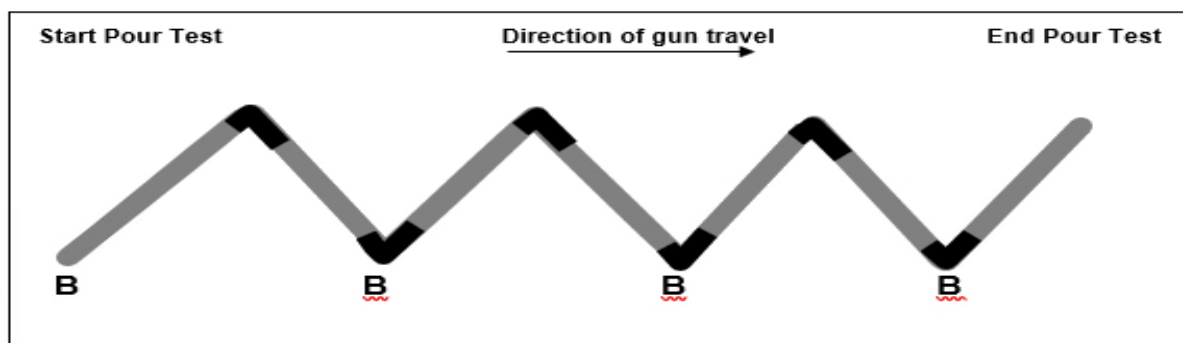
Example:

Flushing and Shutting Down

When finished dispensing, it is necessary to always flush and clean the mixer and mix housing to prevent hardened material building up and clogging the mixer.

1. Trigger the gun momentarily to allow pump shafts to run to the fully lowered position.
2. Release the gun trigger.
3. Position the outlet of the mixer into an approved waste container.
4. Slowly open the 3-way flush valve to air and air purge the gun for 4-5 seconds.
5. Turn the 3-way valve to solvent and solvent purge for 4-5 seconds.
6. Repeat both air and solvent purges several times as needed to fully flush the gun.
7. Remove the mix chamber and push out the mixer elements into a container for cleaning.
8. Use a bottle brush to clean out the mixer housing and clean the mixer elements by hand, as appropriate.
9. Inspect the mixer elements for blockage, wear, or breakage and replace as necessary.

10. Turn off the main air to the system.
11. Relieve the air pressure from the flush tank by lifting the relief valve ring.

Changing an Empty Pail

1. Move the ram control lever to the neutral (center) position.
2. Open the ball valve connected to the ram extraction gauge.
3. Slowly turn up the ram extraction regulator to 25 psi (1.7 bar).
4. Move the ram control lever to the up position.
5. Adjust the air lift pressure regulator to 20 psi (1.4 bar).
6. Close and open the ram control lever intermittently to raise the follow and pump out of the pail, holding the container down if it begins to lift.

Note *It may be necessary to adjust both the air lift and ram extraction pressures to facilitate removal without lifting the pail.*

7. After pump and follower are removed, inspect, seal, and dispose of protective boot.
8. Clean any buildup of material from piston seals and follower plate.

Note *If seals need to be replaced, refer to the information in the table below.*

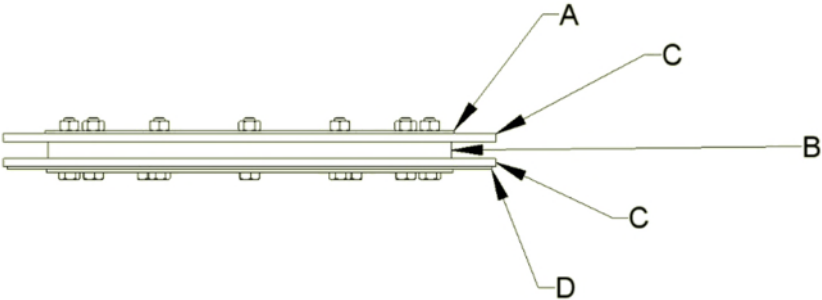

Upper Plate (A)	Spacer Plate (B)	Seal (C)	Wiper (D)
PAT-RA-5020 (9.5" OD)*	PAT-RA-5019 (9.5" OD)*	PAT-RA-5015 EPDM 3/16 x 11-7/16" OD (290.5mm)	PAT-RA-5018 UHMW* .06 x 11-1/4" OD (285.8mm)
" "	" "	PAT-RA-5016 URETHANE* 3/16 x 11-7/16" OD (290.5mm)	" "
" "	" "	PAT-RA-5015-L LEATHER 3/16 x 11-7/16" OD (290.5mm)	" "
" "	" "	PAT-RA-5030 EPDM 3/16 x 11.61" OD (295mm)	PAT-RA-5032 EPDM 3/16 x 11.42" OD (290mm)

Upper Plate (A)	Spacer Plate (B)	Seal (C)	Wiper (D)
“ “	“ “	PAT-RA-5031 URETHANE 3/16 x 11.61” OD (295mm)	PAT-RA-5033 URETHANE 3/16 x 11.42” OD (290mm)
PAT-RA-5035 (10.34” OD)	PAT-RA-5036 (10.34” OD)	PAT-RA-5040 EPDM 3/16 x 12.28” OD (312mm)	PAT-RA-5042 UHMW .04 x 12.17” OD (309mm)
“ “	“ “	PAT-RA-5041 URETHANE 3/16 x 12.28” OD (312mm)	“ “
“ “	“ “	PAT-RA-5050 EPDM 3/16 x 13” OD (330.2mm) **	PAT-RA-5052 UHMW .04 x 12.82 OD (325.6mm) **
“ “	“ “	PAT-RA-5051 URETHANE 3/16 x 13” OD (330.2mm) **	“ “

* Standard on Putty Unit

** Will not work on DUO 5-Gallon Unit

9. Replace the container with a full container and return to the steps for Priming the Unit.

Performing Daily Tasks

Daily Start Up

1. Check and refill all components and materials.
2. Close the relief valve on the flush tank lid.
3. Open the main air supply lockout ball valve to pressurize the system
4. Bleed off any water.
5. Check the system for leaks or damage and repair or replace items as necessary.
6. Check that air lift and pump pressure settings are set to the appropriate setting, adjust as needed.
7. Apply a small amount of lubricant to the threads of the mix chamber.
8. Reassemble and attach the mixer assembly.
9. Check the flush system for proper operation.

The system is ready for use.

Daily Shut Down

10. Drain the water trap filter.
11. Thoroughly flush and clean the mix chamber.
12. Remove the mixer and mixer plug from the mix chamber.
13. Remove the mix chamber and clean with solvent.

14. Wipe the front of the gun block clean and inspect for damage.
15. Close the lockout ball valve to relieve air pressure from the system.
16. Lift the relief valve on the flush tank lid to release flush tank pressure.
17. Open and then close the catalyst recirculation valve on the catalyst manifold to relieve the catalyst pressure.

Note ***Do not leave the barrel piston in the material if the system will be idle for more than 2 weeks.***